

SPOKANE METAL PRODUCTS

Spokane Washington

CONFIDENTIAL PROPRIETARY INFORMATION
Reproduction of this data or the manufacturing of products from
this data by anyone other than Spokane Metal Products of Spokane
Washington is strictly prohibited without written consent

200 GALLON FUEL BOWSER

TECHNICAL MANUAL

PARTS, OPERATION AND MAINTENANCE

MODEL NUMBER BOW 200-07

© COPYRIGHT 1991 By SPOKANE INDUSTRIES INC.
ALL RIGHTS RESERVED

This document discloses subject matter in which Spokane Metal Products has Proprietary rights and such subject matter shall not, without the written permission of Spokane Metal Products, be either (A) used, released or disclosed in whole or in part outside the government, (B) used in whole or in part by the government for manufacture, or (C) used by a party other than the government, except for (1) emergency repair or overhaul work only, by or for the government, where the item or process concerned is not otherwise reasonably available to enable timely performance of the work, provided that release or disclosure hereof outside the government shall be made subject to a prohibition against further use, release or disclosure, or (2) release to a foreign government, or for emergency repair or overhaul work by or for such government under the conditions of (1) above. This legend shall be marked on any reproduction hereof in whole or in part.

200 GALLON FUEL BOWSER

TECHNICAL MANUAL

PARTS, OPERATION AND MAINTENANCE

MODEL NUMBER BOW 200-07

INDEX

	<u>Page</u>
<u>Section 1.</u> Introduction	1
<u>Section 2.</u> Safety	1
<u>Section 3.</u> Operation	
3.1 Intended Use	2
3.2 Parking Brake	2
3.3 Tow Bar and Under Carriage	2
3.4 Telescoping Drain Assembly	3
3.5 Vacuum Assembly	4
3.6 Grounding Reels	4
3.7 Drain Valve	5
3.8 Sample Port	5
3.9 Telescoping Drain Strainer	5
3.10 Vent Overflow Preventor	5
<u>Section 4.</u> Maintenance	
4.1 Parking Brake	5
4.2 Under Carriage and Tow Bar	6
4.3 Telescoping Drain Assembly	6
4.4 Vacuum Assembly	6
4.5 Grounding Reels	6
4.6 Sight Gauge	7
4.7 Telescoping Drain Strainer	7
4.8 Vent Overflow Preventor	7

<u>Section 5.</u>	Replacement Parts	9
5.1	Main Tank	10
5.2	Under Carriage	
	Axle, Front	12
	Axle, Rear	15
	Brake, Parking	16
	Wheel Assembly, Front	18
	Wheel Assembly, Rear	20
5.3	Manway Assembly	22
5.4	Decal Package	23
5.5	Telescoping Drain	25
5.6	Vacuum Assembly	28
5.7	Miscellaneous Fixtures	31
5.8	Drain Sump Assembly	34
5.9	Vent, Overflow Preventor	35
5.10	DIAPHRAGM PUMP	36
<u>Warranty</u>	44

1.0 INTRODUCTION

- 1.1 To obtain optimum benefit from your fuel bowser unit, it is recommended that all personnel operating it read and understand this manual prior to operation.
- 1.2 Upon receipt of the Bowser unit, a visual inspection should be made to determine that it is complete and has not sustained any damage during transportation.

2.0 SAFETY

2.1 Potential Fire Or Explosion

- 2.1.1 Due to the nature of fuel, care should be exercised to eliminate all sparks and open flame in the area of the fuel bowser.
- 2.1.2 A 50 foot radius area around the fuel bowser for no smoking, sparks, or open flames is usually a good practice. It is strongly recommended all local or other regulations be consulted for further restrictions.

2.2 Telescoping Drain

- 2.2.1 Care should be exercised in using the telescope to prevent injury fingers between clamps by dropping sections.

2.3 Grounding

- 2.3.1 To eliminate static sparks, the bowser unit is equipped with two grounding reels which should be connected prior to draining or filling operations.

2.4 Towing

- 2.4.1 Make sure the tow bar is securely attached to the towing vehicle.
- 2.4.2 Before moving the bowser unit, check to assure the parking brake is released.
- 2.4.3 Maximum allowable towing speed is 15 MPH.

2.5 Parking

- 2.5.1 Parking brake must be applied when filling and draining or when left unattended.

2.6 Air Supply

2.6.1 Caution: Check the air pressure of supply lines to the vacuum generator to assure it is not in excess of 100 PSI. AND 50 PSI TO THE DIAPHRAGM PUMP.

2.7 Inspections

2.7.1 Inspection of tires, undercarriage, tow bar, vent, valves, hoses, sight gauge, reflectors, safety labels, etc., should be inspected on a periodic basis. It is recommended these inspections be performed weekly.

2.7.2 Internal inspection will be necessary to insure structural integrity and cleanliness. It is recommended that interval inspections be performed at least every (6) six months. Caution! When entering confined spaces such as the interior of the bowser tank, care should be taken to provide proper breathing equipment and a separate person dedicated solely to a safety watch of the person inside. It is strongly recommended that all local or other regulations be consulted.

3.0 OPERATION

3.1 Intended Use

3.1.1 The fuel bowser unit is intended for use in draining and collection of fuel from aircraft and the transportation to a disposal site. Any other use is prohibited and may void any and all warranties.

3.2 Parking Brake

3.2.1 The bowser unit is equipped with a mechanically operated parking brake. The brake should be applied prior to disengaging tow bar. The brake should be applied when filling, or draining tank, or whenever left unattended.

3.3 Tow Bar and Undercarriage

3.3.1 The bowser unit is equipped with steerable front wheels controlled by the tow bar.

3.3.2 Care should be taken not to jackknife the bowser when backing up.

3.3.3 Tire inflation should be checked and maintained as described in the maintenance section.

3.3.4 Before towing, check to see the brake is disengaged, grounding reel and hoses are disconnected, valves are closed, tow bar is securely attached to the towing vehicle, telescoping drain is collapsed, and all manways and covers are closed and latched.

3.3.5 The bowser unit is equipped with a tow bar latch to hold it in the upright position.

3.4 Telescoping Drain Assembly

3.4.1 The fuel bowser is equipped with a telescoping drain assembly. It is capable of being adjusted from 4'2" to 12'0" high.

3.4.2 To Raise:

- (1) Loosen top clamp if necessary.
- (2) Grasp top section with one hand and lift until the top clamp raises approximately 6 inches.
- (3) Tighten clamp securely with the other hand.
- (4) Reposition lifting hand by grasping tube below tightened clamp and lift until next clamp is raised approximately 6 inches.
- (5) Repeat steps 1-4 until desired height is obtained or assembly is fully extended.

3.4.3 To Lower:

- (1) Tightly grasp bottom extended tube with one hand and loosen the securing clamp.
- (2) Slowly lower tube, hand over hand, until the following clamp is resting on the loosed clamp.
- (3) Repeat steps 1 and 2 until all sections are lowered.

3.4.4 Funnel is equipped with a nitrile rubber seal around the top edge to allow placement against the underside of a wing.

3.4.5 When not in use, telescope should be collapsed and the cover closed to eliminate contamination.

3.5 Vacuum Assembly

3.5.1 This assembly is equipped with an air powered vacuum generator.

3.5.2 It is intended for vacuum draining or depuddling fuel and condensation. Caution! If other objects such as rock or metallic pieces are vacuumed into the vacuum chamber, they may create a hazard due to sparks.

3.5.3 Vacuum is started by attaching a recommended air supply of 60CFM at 100 PSI and turning on the air supply valve.

3.5.5 The vacuum generator is equipped with an automatic overflow protector. When the level of product is full, the valve shuts off and eliminates the vacuum.

3.5.6 The vacuum assembly is supplied with 50 feet of vacuum hose and a ball valve on the vacuum suction.

3.5.7 The vacuum assembly is equipped with (4) four each 1/2" NPT opening for use with pencil drains. To use, the pipe caps must be removed and self-closing quick disconnects attached that match local standards. To operate, close vacuum suction valve and turn air supply on and connect drain lines.

3.6 Grounding Reels

3.6.1 The bowser unit is supplied with two grounding reels.

3.6.2 Before filling, draining, or vacuuming, the grounding reels must be attached to the aircraft or object being serviced and an appropriate ground.

3.7 Drain Valves

3.7.1 The bowser unit is equipped with a 1-1/2" NPT ball valve with a camlock connector.

3.8 Sample Port

3.8.1 The bowser unit is equipped with a 1/2" NPT valve for use as a sample port.

3.9 Telescoping Drain Strainer

3.9.1 The bowser unit is equipped with a sump with removable bottom to allow cleaning of the drain strainer.

3.10 Vent Overflow Protector

3.10.1 The bowser unit is equipped with a float actuated seal to prevent fuel from flowing out the vent in the event the bowser is overfilled.

4.0 MAINTENANCE

4.1 Parking Brake

4.1.1 The bowser unit is equipped with a parking brake assembly consisting of a 7" diameter brake drum with 2-1/4" wide brake shoes.

4.1.2 The shoes are activated via a mechanical linkage, eccentric and lever.

4.1.3 Adjustment may be necessary as the shoes wear.

- (1) Tightening is accomplished by removing the bolt through one yoke and screwing yoke in to shorten connecting rod.
- (2) Do not over tighten or brakes may drag when released.

4.1.4 Replacement of shoes.

- (1) Remove wheel.
- (2) Remove nut retaining hub and drum assembly.
- (3) Disconnect actuating rod.
- (4) Remove shoe retainers.
- (5) Install new shoes.
- (6) Replace shoe retainers.
- (7) Adjust actuator rod length.
- (8) Replace wheel.

4.2 Under Carriage and Tow Bar

4.2.1 The bowser unit is equipped with steerable front wheels, fixed rear wheels, and a tow bar.

4.2.2 Maintenance should consist of the following:

- (1) King pin bushing, turning bushings and tie rod ends are self lubricating and need no additional maintenance.
- (2) Pack wheel bearing at intervals not to exceed three (3) months.
- (3) Check tire pressure weekly. Pressure should be maintained at 60 PSI.

4.2.3 Tow bar pivot pin and hook ring should be inspected monthly for excessive wear or cracks.

4.3 Telescoping Drain Assembly

4.3.1 The telescoping Drain Assembly consists of stainless steel housing 4" in diameter permanently attached to the tank and four aluminum tube sections.

4.3.2 The stainless tube and four largest aluminum tubes are equipped with a clamp assembly.

4.3.4 Each aluminum tube is crimped on the lower end which acts as a stop to prevent the tube from sliding through the clamp.

4.3.5 Disassembling of the telescope assembly is accomplished by rotating the four sections 180 degrees from normal position and gently lifting each section so that the crimped edge on the tube is aligned with the slot on the clamp.

4.4 Vacuum Assembly

4.4.1 The vacuum assembly consists of a vacuum chamber with an air powered vacuum generator mounted on a removable cover. The cover is held in place by three (3) eccentric latches.

- 4.4.3 The vacuum cover is equipped with an overflow valve which should require no maintenance.
- 4.4.4 The vacuum generator is attached to the chamber cover. It is equipped with an exhaust silencer which should be cleaned at six (6) month intervals or more often depending on the amount of use and conditions.
- 4.4.5 The vacuum hose should be inspected monthly for cracks. Any sudden loss of vacuum suction power may indicate a crack in the vacuum hose.
- 4.4.6 The cover gasket should be inspected monthly for deterioration. This gasket should be pliable and free from weather checking.
- 4.4.7 The overflow stop pivot bolts should not be overtightened. Over tightening will restrict motion of the floats.
- 4.5 Grounding Reels
- 4.5.1 Grounding reel cables should be pulled out, cleaned and inspected monthly.
- 4.5.2 Cable clamps and ends should be inspected for loose connections monthly.
- 4.6 Sight Gauge
- 4.6.1 The sight gauge should be inspected monthly for loose connections and weathering of clear tubing.
- 4.7 Telescoping Drain Strainer
- 4.7.1 Telescoping drain strainer is located on the bottom of the stainless steel drain housing.
- 4.7.2 Maintenance should consist of inspection and cleaning monthly.
- 4.7.3 Removal:
- (1) Removal is accomplished by loosening the wing nut on the clamp holding the base of the sump. NOTE! Check interior to assure fuel has been thoroughly drained before loosening wing nut.
 - (2) Remove clamp and sump base.
 - (3) Loosen clamp holding screen to stainless steel drain housing and pull screen down.
- 4.8 Vent Overflow Preventor
- 4.8.1 The vent overflow preventor is located inside the tank directly under the vent.
- 4.8.2 It consists of a caged float with an elastomer seal.

4.9 TROUBLE SHOOTING

<u>SYMPTOM</u>	<u>PROBABLE CAUSE</u>	<u>PROBABLE CORRECTIONS</u>
Bowser does not track or steer correctly or steers loosely	Bent King Pin housing see section 5.2.1 Item #7	Replace King Pin housing
	Defective Tie Rod End see section 5.2.1 Item #12	Replace Tie Rod End
	Loose or worn out Bushings, see section 5.2.1 Items #11,16 or 18	Replace as needed
Toe Bar does not stay in the upright position	Broken or stretched spring see section 5.2.1 Item #26	Replace as needed
Parking Brake does not work	Need adjustment	Adjust as per instructions in section 4.1.0
	Needs repairing see section 5.2.3	Replace as needed
Vacuum System does not have much suction	Defective lower drain stop gasket, see section 5.6 Item #2	Replace as needed
	Not enough air pressure to operate vacuum generator, see section 3.5.3 and 4.4	Increase air pressure and volume
	Plugged outlet Filter see section 5.6	Replace or clean as required
Fuel misting is occurring through vacuum generator	Bowser tank is to full	Empty main Bowser tank
	Overflow stop gasket needs replacing or adjusting, see section 3.5.0 and 5.6	Replace or adjust as needed
	Float on Vacuum shut-off is bent, see section 5.6	Fix or repair as needed

SYMPTOM PROBABLE CAUSE PROBABLE CORRECTIONS

Telescoping Drain won,t stay up Loose clamp handles Tighten handles a little tighter
Worn Sleeve Clamp Liners, Replace as needed
see section 5.5

Telescoping Drain is over flowing Bowser tank is full Empty main Bowser tank
Clogged screen or strainer, see section 4.7 and or 5.5 Remove and clean as required

5.0 REPLACEMENT PARTS

This section provides information for identification of parts for ordering. To order, it is important to have the Model Number, Subassembly Number, Part Number and Description. Parts may be ordered by calling or writing to:

SPOKANE METAL PRODUCTS
P.O. Box 3303
Spokane, WA 99220-3303
Telephone: (509)928-0720
Tele Fax:(509)927-0826

CONFIDENTIAL PROPRIETARY INFORMATION
 Reproduction of this data or the manufacturing of products from
 this data by anyone other than Spokane Metal Products of
 Spokane, WA is strictly prohibited without written consent.

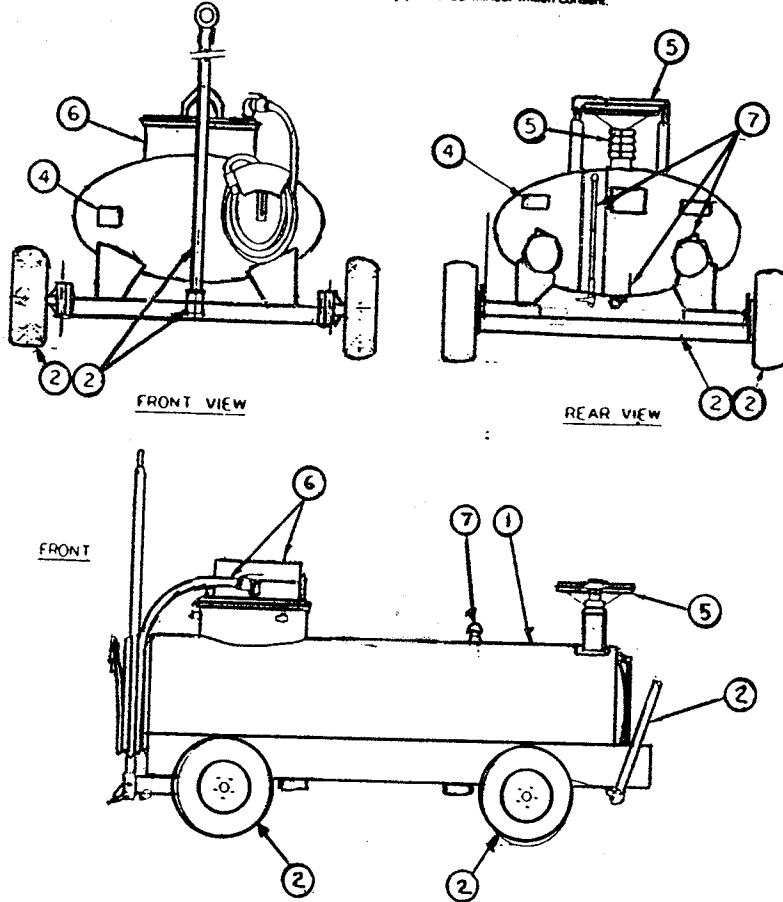

<u>Item No.</u>		<u>Section</u>
1	Main Tank	5.1
2	Axle, Front	5.2.1
2	Axle, Rear	5.2.2
2	Brake, Parking	5.2.3
2	Wheel Assembly, Front	5.2.4
2	Wheel Assembly, Rear	5.2.5
4	Decal Package	5.4
5	Telescoping Drain	5.5
6	Vacuum Assembly	5.6
7	Miscellaneous Fixtures	5.7
7	Vent, Overflow Preventor	5.8

SPOKANE METAL PRODUCTS

SPOKANE WASHINGTON
CONFIDENTIAL PROPRIETARY INFORMATION

Reproduction of this data or the manufacturing of products from this data by anyone other than Spokane Metal Products of Spokane WA is strictly prohibited without written consent.

501

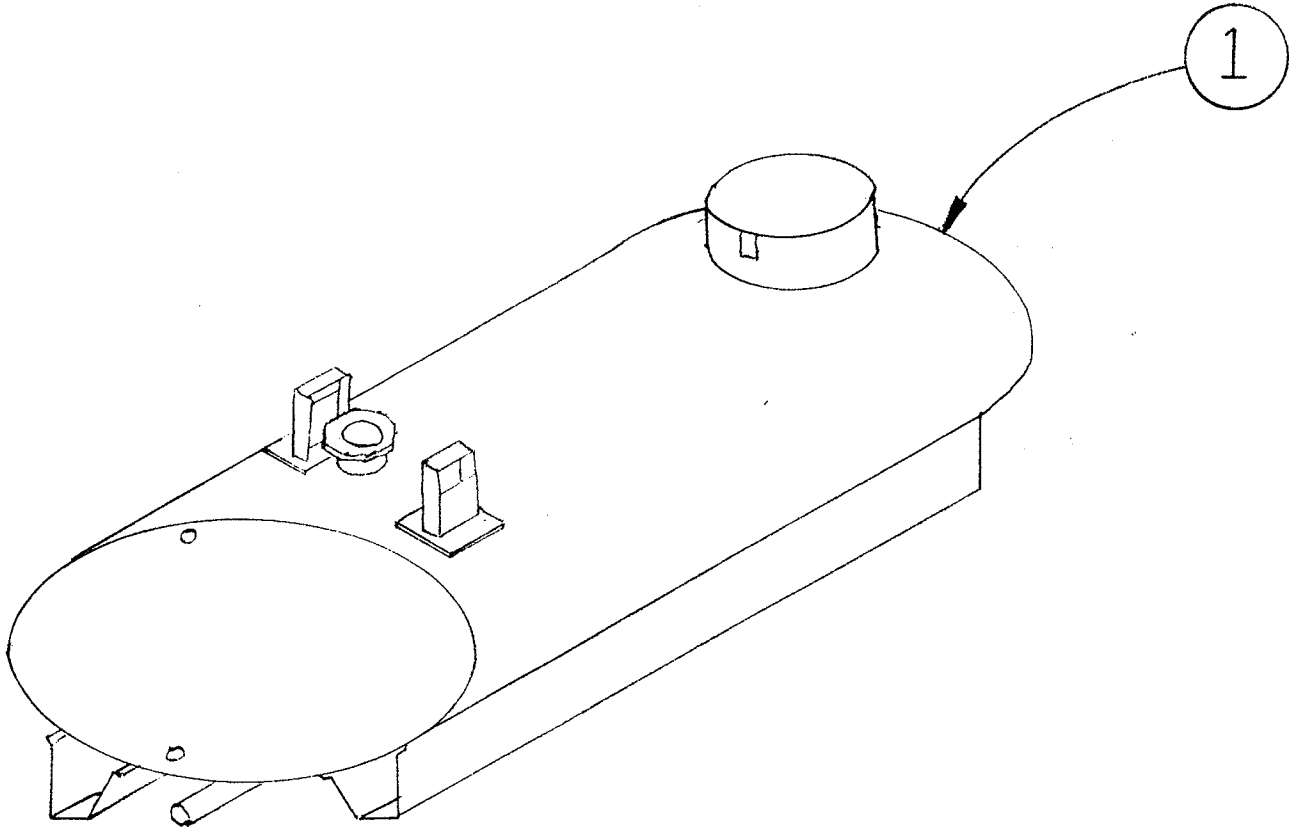

ASSEMBLY NO. *S/O 8068*

MAJOR ASSEMBLY - TANK WELDMENT

Sub Assy.	Item	Part No.	Quantity	Description	Wt. #
	1	<i>W/O 11059</i>	1	<i>SPECIAL DOUBLE WALL</i> Stainless Steel Tank Weldment, 200 Gallon Capacity Series BOW 200-07	375#

SECTION 5.2.1

PO Box 3621 Spokane, WA 99220 • Pkg. 4, Spokane Industrial Park • (509) 325 0730 • TWX 38 0430

CONFIDENTIAL-PROPRIETARY INFORMATION
 REPRODUCTION OF THESE DRAWINGS OR THE MANUFACTURING OF PRODUCTS FROM THESE DRAWINGS FOR USE BY ANY
 ONE OTHER THAN SPOKANE METAL PRODUCTS OF SPOKANE, WA IS STRICTLY PROHIBITED WITHOUT WRITTEN CONSENT

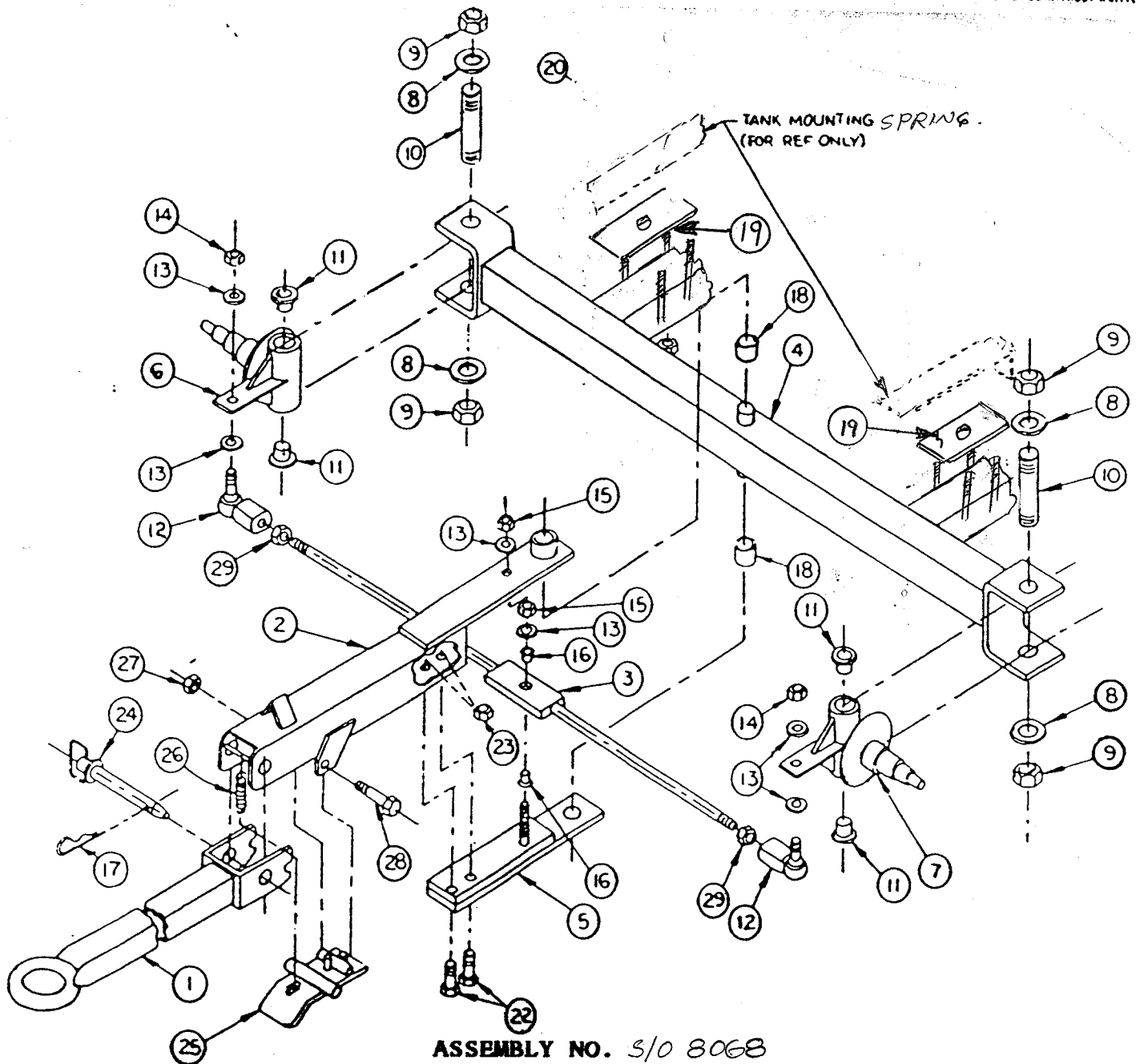

MAJOR ASSEMBLY - AXLE ASSEMBLY

Sub Assy.	Item	Part No.	Quantity	Description	Wt. #
S/O 8068				Axle, Assembly, Front	
	1	07-1103	1	Tow Bar	23
	2	07-1052	1	Arm, Turning	16
	3	W/O 11059	1	Tie Rod	7.3
	4	W/O 11059	1	Axle, Front	53

ASSEMBLY NO 5/0 8068

MAJOR ASSEMBLY - AXLE ASSEMBLY (CONTINUED)

Sub Assy.	Item	Part No.	Quantity	Description	Wt. #
	5	07-1046	1	Steering Arm, Lower Plate	6.1
	6	05-1009	1	Sleeve, King Pin, Right	24
	7	05-1009	1	Sleeve, King Pin, Left	24
	8	02-11131	4	Washer, King Pin	1
	9	02-12131	4	Nut, King Pin	2
	10	05-1010	2	King Pin	11
	11	03-1013	4	Bushing, King Pin Sleeve	1
	12	03-1016	2	Ends, Tie Rod	5
	13	02-11072	5	Washers, Tie Rod	
	14	02-12071	2	Nuts, Tie Rod Ends	1
	15	02-12071	1	Nut, Tie Rod Pivot	.5
	16	03-1015	2	Bushing, Tie Rod Pivot	.8
	17	02-1300	2	Cotter Pin	.2
	18	03-1014	2	Bushing, Axle Pivot	1
	19	<i>w/o 11059</i>	2	Mounting Pad, Tank	4
	20				
	21	<i>w/o 11059</i>	4	Nuts, Tank Mounting	.5
	22	02-1502	2	Bolts, Turning Arm Clamp	.32
	23	02-12041	2	Nuts, Turning Arm Clamp	.2
	24	02-1304	1	Hitch Pin	2
	25	07-1020	1	Toe Latch	3.1
	26	04-1054	1	Spring, Toe Latch	.5
	27	02-1201	1	Nut, Toe Latch	.1
	28	02-1501	1	Bolt, Toe Latch	.2
	29	02-12141	2	Hex Nut, Tie Rod	.2

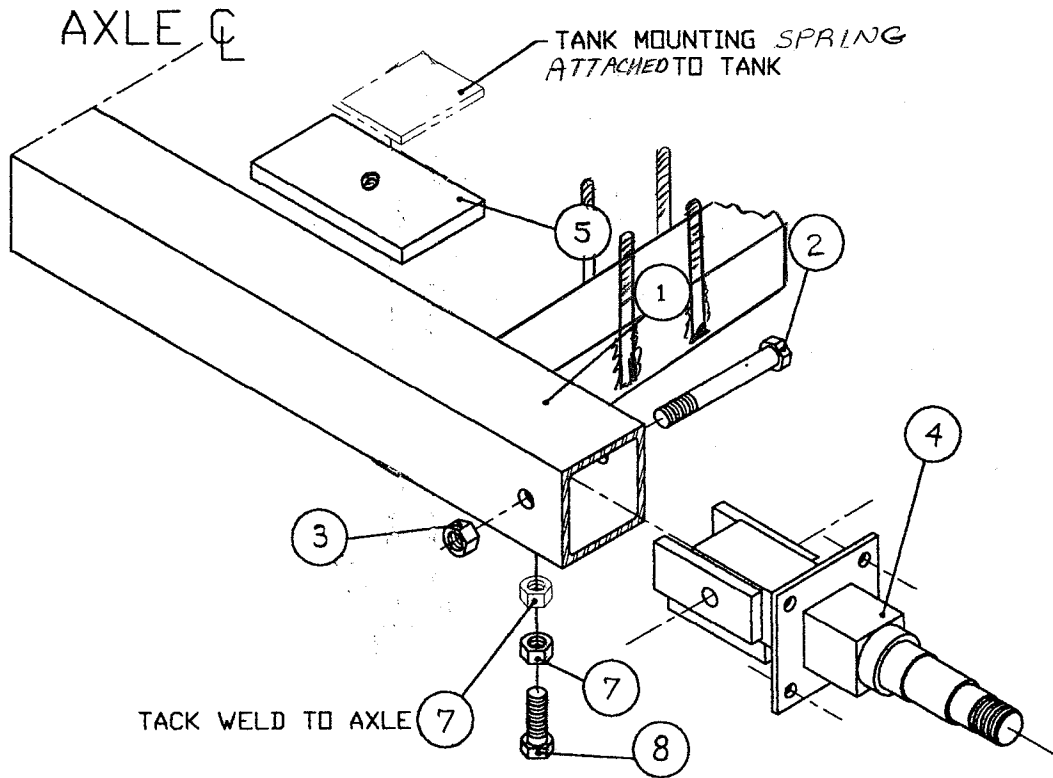

ASSEMBLY NO. S/O 8068

MAJOR ASSEMBLY - AXLE ASSEMBLY

Sub. Assy.	Item	Part No.	Qty.	Description	Wt.
S/O 8068				Axle Assembly, Rear	
	1	W/O 11059	1	Axle, Rear Weldment	40
	2	02-1505	2	Bolts, Mounting Spindle	.6
	3	02-12041	2	Nuts, Mounting Spindle	.5
	4	05-1022	2	Spindle, Rear	17
	5	W/O 11059	2	Mounting Pad, Tank	1
	6				
	7	W/O 11059	4	Nuts, Tank Mounting	.5
	8	02-10041	2	Bolt, Spindle Stabilizer	.5

CONFIDENTIAL PROPRIETARY INFORMATION
 Reproduction of this data or the manufacturing of products from
 this data by anyone other than Spokane Metal Products of
 Spokane, WA is strictly prohibited without written consent

SECTION 5.2.3.

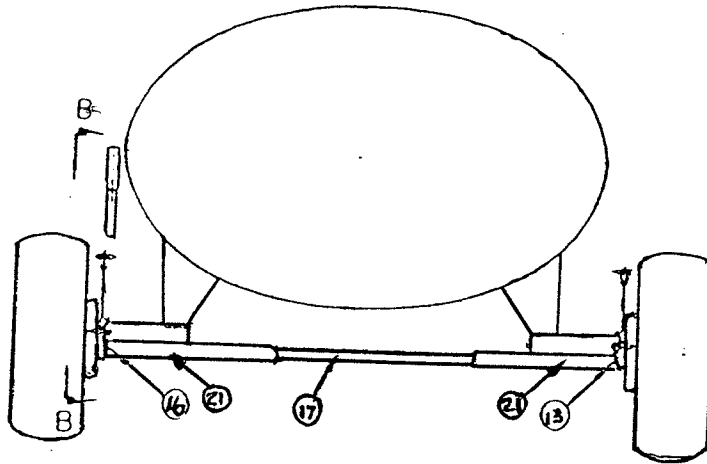
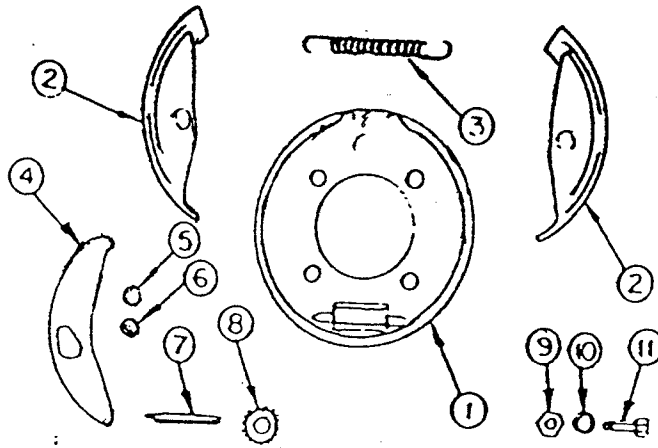

REAR VIEW
 NTS

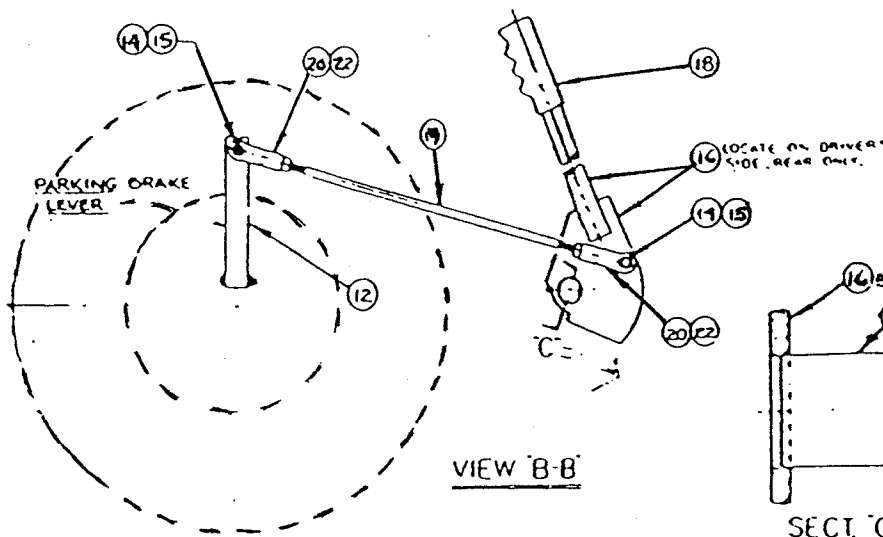

VIEW 'B-B'

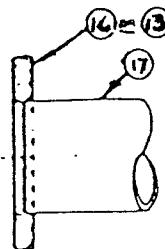

SECT. 'C' (REF VIEW 'D')

ASSEMBLY NO. 10-100030

MAJOR ASSEMBLY - BRAKE, PARKING

Sub Assy.	Item	Part No.	Quantity	Description	Wt.#
08-1007		04-1063		Brake Assembly (2 Req'd)	
	1	04-1023	1	Brake, Plate Assembly	7
	2	04-1024	1	Brake, Shoe Assembly	4
	3	04-1026	2	Brake, Shoe Lever Spring	1
	4	04-1025	2	Brake, Shoe Lever	1
	5	02-1400	2	1\2" Retaining Ring	.2
	6	02-1303	2	Anchor Pin	.2
	7/8	04-1027	2	Adjusting Screw Assembly	.7
	9	02-12031	4	Nut	.2
	10	02-11031	4	Lockwasher	.1
	11	02-10031	4	Bolt, 7/16" Shoulder	.5
	12	04-1030	1	Brake, Control Arm	3
08-1008				Brake Linkage Assembly	
	13	05-1025	1	Cam, Brake Linkage	1.4
	14	02-10012	1	Bolt	.4
	15	02-12021	1	Nut	.1
	16	07-1033	1	Brake Handle, Fabd Sub-Ass	5.4
	17	01-8104	1	Brake Handle, Connector	4
	18	04-1055	1	Grip, Vinyl	1
	19	05-1026	1	Rod, Brake Linkage	1
	20	04-2516	4	Yoke Ends	.5
	21	03-1020	2	Grease Fitting	.5
	22	02-100231	4	Jam Nut, 3/8"	.5

CONFIDENTIAL PROPRIETARY INFORMATION
Reproduction of this data or the manufacturing of products from
this data by anyone other than Spokane Metal Products of
Spokane, WA is strictly prohibited without written consent.

SECTION 5.2.4.

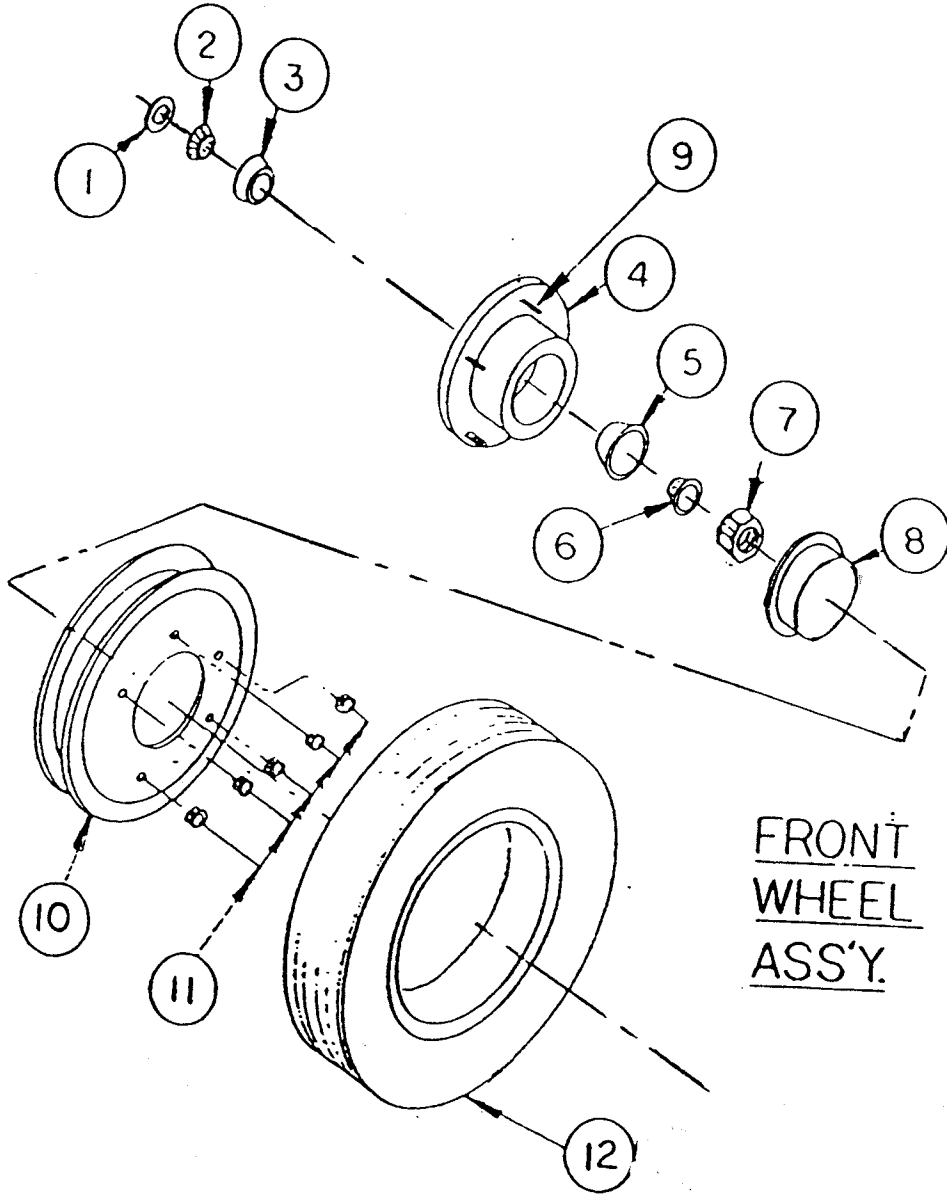

FRONT
WHEEL
ASS'Y.

ASSEMBLY NO. 10-100042

MAJOR ASSEMBLY - WHEEL ASSEMBLY, FRONT

Sub Assy.	Item	Part No.	Quantity	Description	Wt. †
08-1011		04-1050		Bearing & Hub Assembly (2 Reqd)	
	1	04-1012	1	Seal, Bearing	1
	2	04-1013	1	Bearing, Inner	3
	3	04-1015	1	Cup, Inner	2
	4	04-1017	1	Hub, Wheel	7
	5	04-1016	1	Cup, Outer	4
	6	04-1014	1	Bearing, Outer	3
	7	02-1205	1	Spindle Nut	1
	8	04-1019	1	Dust Cap	1
	9	02-1017	5	Studs, Hub	1
<i>S/O 8068</i>		<i>W/O 11059</i>		Tire/Wheel/Tube Assembly (2 Reqd)	
	10	<i>W/O 11059</i>	1	Wheel, 10"	9.5
	11	04-1021	5	Lug Nuts, Wheel	1
	12	04-10221	1	Tire, 10" "B"	4
	13				11

CONFIDENTIAL PROPRIETARY INFORMATION
Reproduction of this data or the manufacturing of products from
this data by anyone other than Spokane Metal Products of
Spokane WA is strictly prohibited without written consent

SECTION 5,2.5.

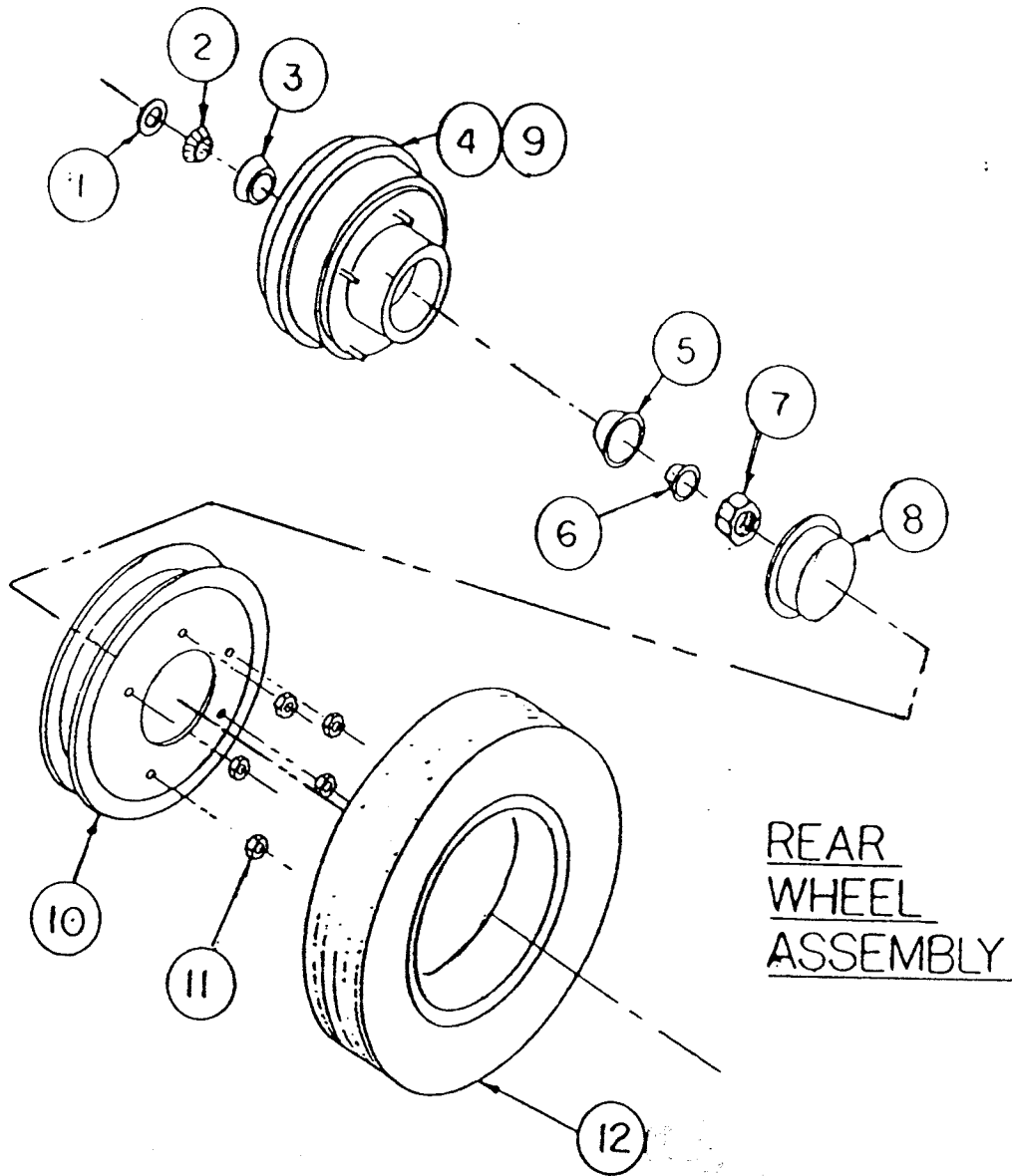

ASSEMBLY NO. 10-100052

MAJOR ASSEMBLY - WHEEL ASSEMBLY, REAR

Sub Assy.	Item	Part No.	Quantity	Description	Wt.#
08-10111		04-1062		Bearing & Hub Assembly (2 Reqd)	
	1	04-1012	1	Seal, Bearing	1
	2	04-1013	1	Bearing, Inner	3
	3	04-1015	1	Cup, Inner	2
	4	05-1008	1	Hub/Brake Drum Sub-Assy	16
	5	04-1016	1	Cup, Outer	4
	6	04-1014	1	Bearing, Outer	3
	7	02-1205	1	Nut, Spindle	1
	8	04-1019	1	Dust Cap	1
<i>S/o 8068</i>		<i>W/o 11059</i>		Tire/Wheel/Tube Assembly (2 Reqd)	
	10	<i>W/o 11059</i>	1	Wheel,	9.5
	11	04-1021	5	Lug Nuts, Wheel	1
	12	04-10221	1	Tire, 10" "B"	4
	13				

CONFIDENTIAL PROPRIETARY INFORMATION

Reproduction of this document or the manufacture of products from this document for use by anyone other than SPOKANE METAL PRODUCTS, INC. of Spokane, Wa. is strictly prohibited without written consent.

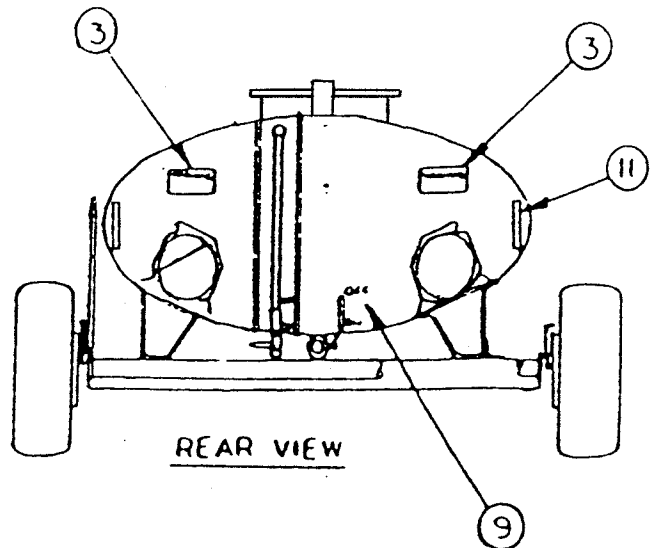
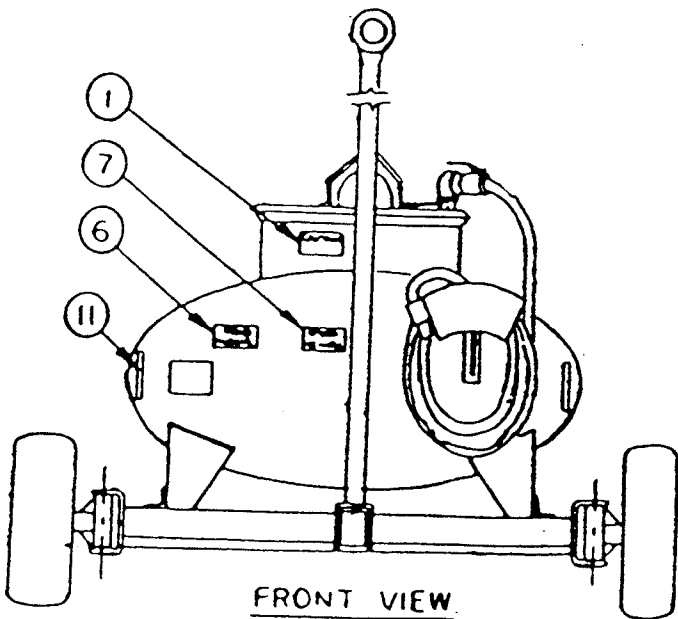
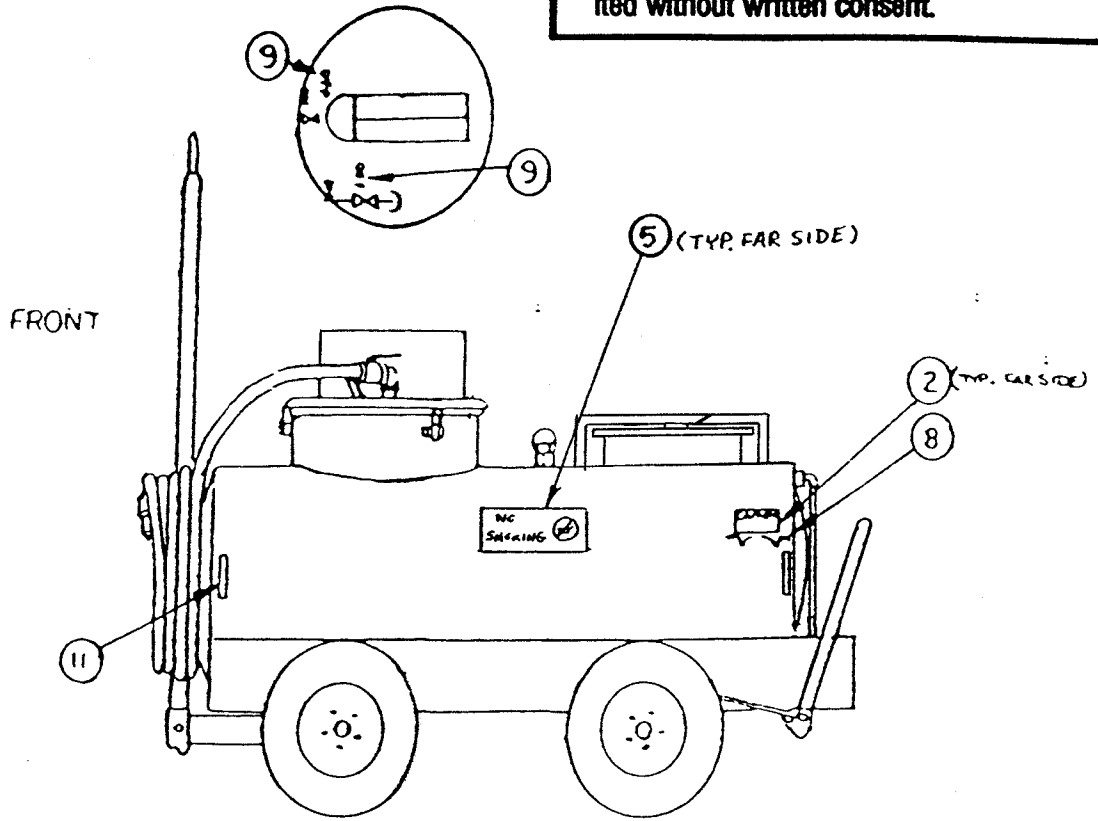

ASSEMBLY NO 10-100070

MAJOR ASSEMBLY - DECAL PACKAGE

Sub Assy.	Item	Part No.	Quantity	Description	Wt.#
10-100070				Decal Assembly	.1
	1	06-1002	1	Caution, Vacuum System	.1
	2	06-1003	1	Caution, Parking Brake	.1
	3	06-1004	2	Warning, Grounding Reels	.1
	4	06-1005	1	Warning, Telescoping Drain	.1
	5	06-1006	2	Danger, No Smoking	.2
	6	06-1007	1	Notice, Read Manual	.1
	7	06-1008	1	Maximum Towing Speed 15MPH	.1
	8	06-1010	1	Off/On, Parking Brake	.1
	9	06-1011	8	Off/On, Drain Valve	.8
	11		8	Reflector Tape	.8

SECTION 5.5

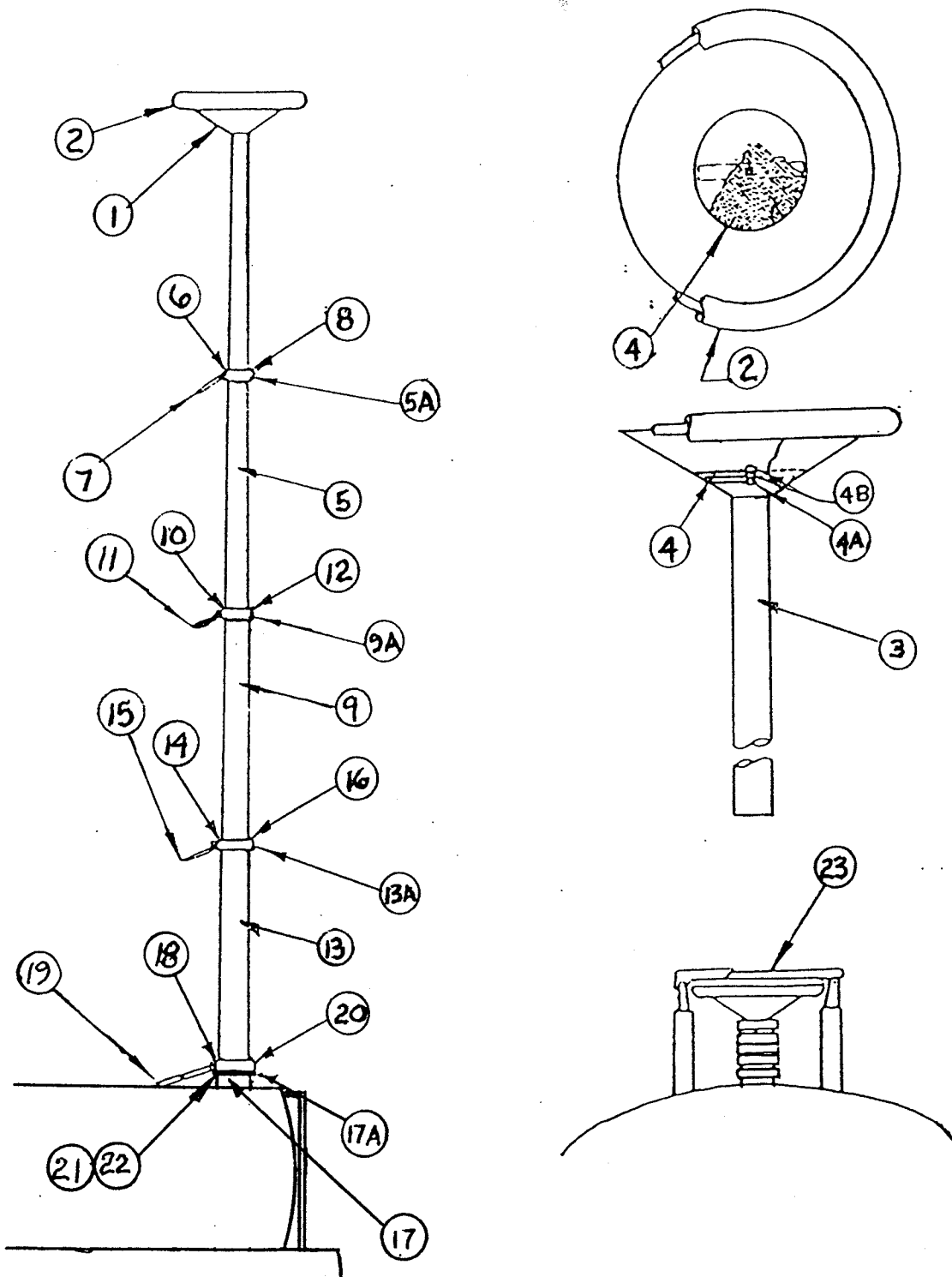

MAJOR ASSEMBLY - TELESCOPING DRAIN ASSEMBLY

Sub Assy.	Item	Part No.	Quantity	Description	Wt.#
07-1054W				Drain Funnel Section Assembly	
	1	01-8250	1	Drain, Top (funnel)	5
	2	06-1022	1	Gasket	.7
	3	01-92402	1	Tubing, 2" OD	
	4	04-1039	1	Screen	.5
	4A	2-10002	1	Bolt, 1/4"	.2
	4B	02-1200	1	Nut, 1/4"	.1
08-1012W				Drain, Telescoping Sect. Assembly, 2-1/2" OD	
	5A	05-10271	1	Clamp, 2"	
	5	01-9242	1	Tubing, 2-1/2" OD	
	6	05-10051	1	WEDGE, 1"x11/16"x1 1/4"	.2
	7	05-10181	1	HANDLE, CLAMP	.3
	8	02-1005	1	SCREW, SET	.01
08-1013W				Drain, Telescoping Sect. Assembly, 3" OD	
	9A	05-10281	1	Clamp, 2-1/2" OD	
	9	01-92452	1	Tubing, 3" OD	
	10	05-10021	1	WEDGE, 1"x7/8"x1 9/16"	.3
	11	05-10181	1	HANDLE, CLAMP	.3
	12	02-1005	1	SCREW, SET	.01

08-1014W				Drain, Telescoping Sect. Assembly, 3-1/2" OD	
	13A	05-10291	1	Clamp, 3" OD	
	13	01-9248	1	Tubing, 3-1/2" OD	
	14	05-10031	1	WEDGE, 1"x1 1/16"x1 13/16"	.4
	15	05-10181	1	HANDLE, CLAMP	.3
	16	02-1005	1	SCREW, SET	.01
07-1041				Drain, Telescoping Section Assembly, 3-1/2" O.D.	
	17A	05-10301	1	Clamp, 3-1/2" OD	
	17	01-9259	1	Tubing, 4" OD	
	18	05-10041	1	WEDGE, 1"x1 7/32"x2 1/8"	.5
	19	05-10181	1	Handles, Clamp	.3
	20	02-1005	1	SCREW, SET	.01
	22A	04-10562	1	Base Flange	
	25	02-100121	4	MOUNTING BOLTS, 1/4-16x3/4"	.2
	26	08-1026	1	COVER ASSEMBLY	5

SECTION 5.6

CONFIDENTIAL PROPRIETARY INFORMATION
Reproduction of this data or the manufacturing of products from this data by anyone other than
Spokane Metal Products of Spokane, WA is strictly prohibited without written consent.

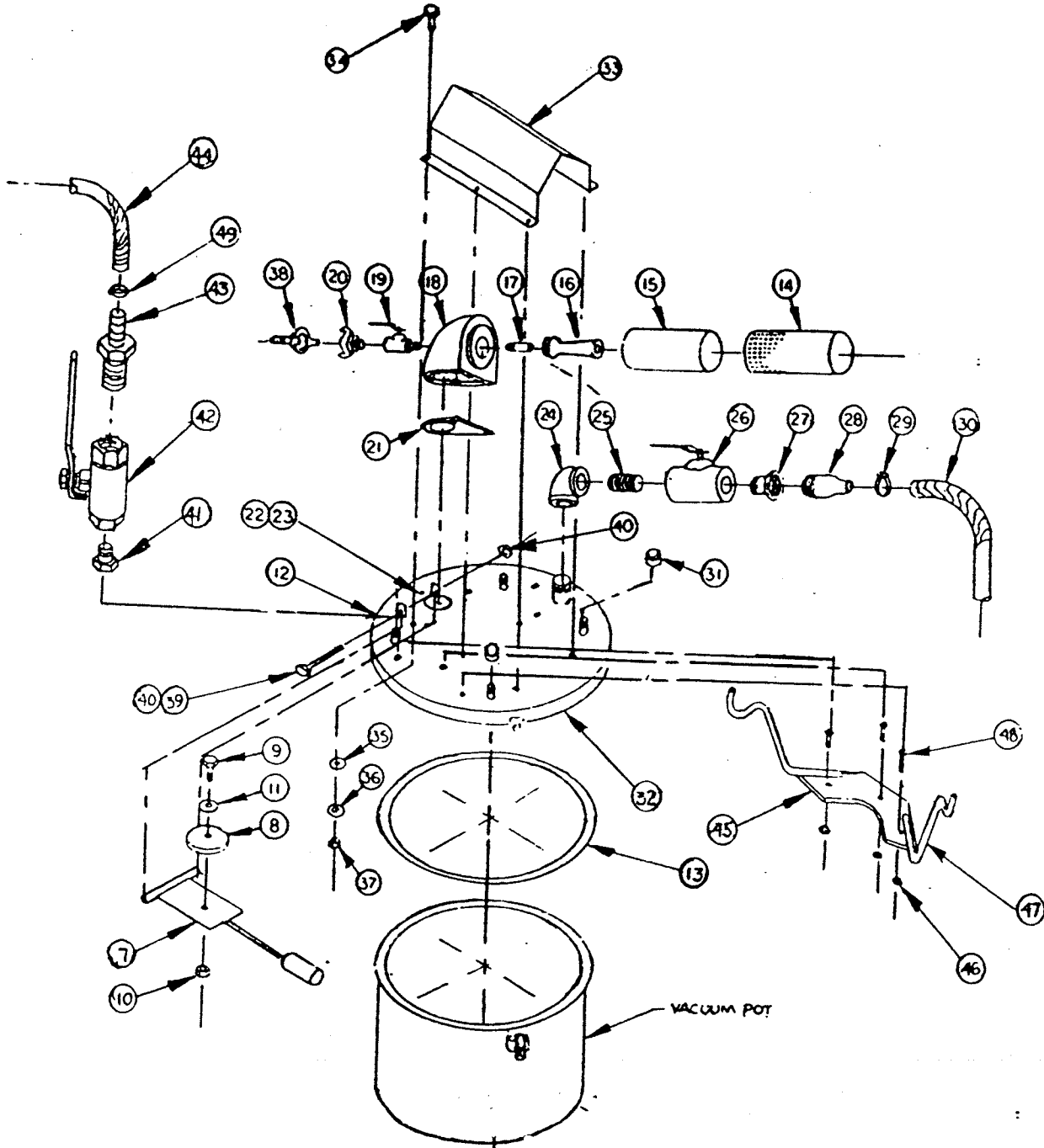

ASSEMBLY NO. 08-0001U

VACUUM SYSTEM ASSEMBLY

Sub Assy.	Item	Part No.	Quantity	Description	Wt.#
	1				3.5
	2				1.5
	3				.1
	4				.1
	5				.1
	6A				.1
	6B				.1
08-1001				Overflow Stop Assembly	
	7	07-1109	1	Float Sub. Assembly	4
	8	04-1001	1	Gasket	.1
	9	02-10003	1	Bolt	.1
	10	02-1200	1	Nut	.1
	11	02-1100	1	Flatwasher	.1
08-10022				Cover Assembly	
	12	07-1002	1	Lid	5
	13	06-1022	1	Gasket	2.7
08-1003				Nortech Vacuum Head Assy.	
	14	04-1004	1	Exhaust Housing	9.5
	15	04-1005	1	Exhaust Silencer	4.7
	16	04-1006	1	Venturi	2.2
	17	04-1007	1	Air Jet	2.7
	18	04-1008	1	Venturi Box	2.7
	19	04-1032	1	Valve	5.8
	20	04-1056	1	Coupler	1.7
	21	04-1010	1	Gasket	.1
	22	02-10010	3	Bolt	.1

ASSEMBLY NO. 08-0001U (CONTINUED)

VACUUM SYSTEM ASSEMBLY

	23	02-11001	3	Washer	.1
08-1004				Accessories	
	24	03-1001	1	Elbow	2
	25	03-02922S	1	Nipple	.5
	26	04-10321	1	Valve	3
	27	03-1002	1	Hex Bushing	.2
	28	03-1003	1	Nipple	.1
	29	03-10101	1	Hose Clamp	.1
	30	06-10161	1	Hose	15
	31	03-1021	4	Pipe Cap (Optional)	1
	32	07-1019	1	Lid	24
	33	07-1034	1	Cover, Vacuum Generator	8
	34	02-10010	6	Bolt	.1
	35	06-1021	6	Washer	.1
	36	02-1100	6	Washer	.1
	37	02-1200	6	Nuts	.1
	38	04-1057	1	Coupler	.5
	39	02-10016	1	Bolt	.5
	40	02-1201	1	Nut	.1
	41	03-10155	4	Bushing (Optional)	.5
	42	04-10320	4	Ball Valve (Optional)	4
	43	03-10091	4	Hose Barb (Optional)	2
	44	06-10185	4	Tubing (Optional)	4
	45	01-9026S	2	Hanger Plate (Optional)	3
	46	02-12014	6	Hex Nuts (Optional)	.5
	47	01-9172S	4	Tubing Hangers (Optional)	2.5
	48	02-100115	6	Bolt (Optional)	1
	49	03-101005	4	Hose Clamp (Optional)	.5

CONFIDENTIAL PROPRIETARY INFORMATION
Reproduction of this data or the manufacturing of products from
this data by anyone other than Spokane Metal Products of
Spokane WA is strictly prohibited without written consent

SECTION 5.7

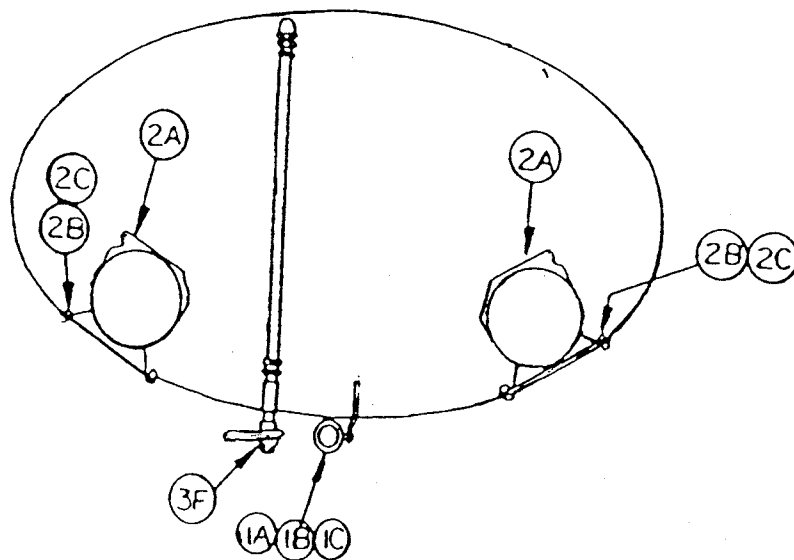
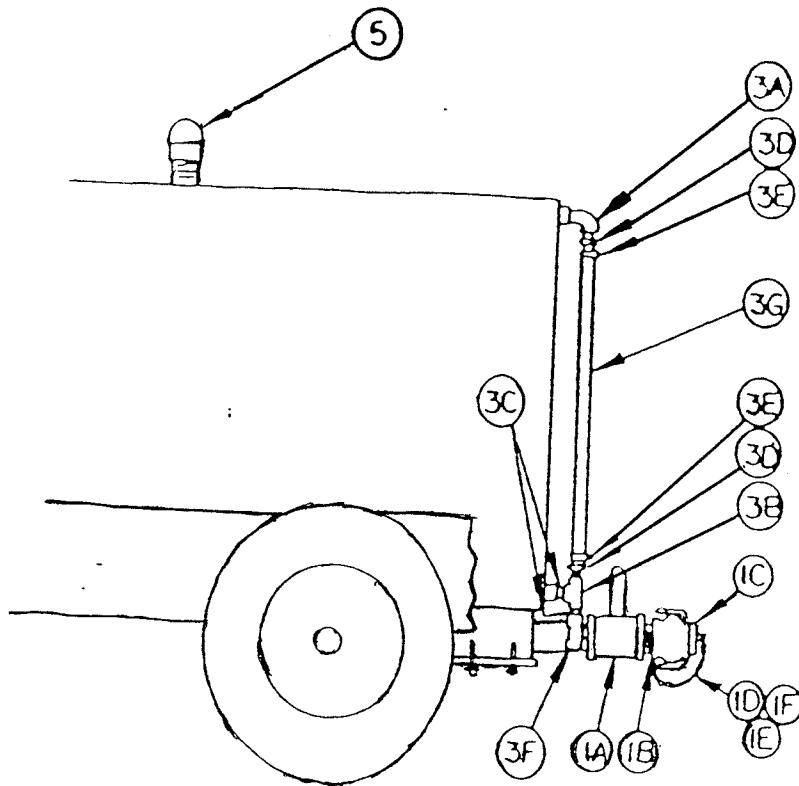

REAR VIEW

ITEM 2A & 2B
**STATIC DISCHARGE GROUNDING REEL
INSTALLATION / OPERATION INSTRUCTION SHEET
P/N 922-30-028**

Introduction

Static Discharge Reels; 200-20R, 700-50R and ML2930 & ML3416 Series to be used for bonding and grounding on mobile fuel equipment at bulk stations, airports, terminals, refineries, et cetera.

Bonding and Grounding Principles

Bonding connects various pieces of conductive equipment together to keep them at the same potential. Static sparking can not occur between objects that are at the same potential.

Grounding is a form of bonding in which conductive equipment is connected to an earthing electrode or to a building grounding system in order to prevent sparking between conductive equipment and grounding structures.

Refer to the National Fire Protection Association Codes, NFPA 77 and NFPA 99 for recommended practice on static electricity.

Reel Installation

Mount Grounding Reel to object or vehicle with bolts using holes provided in base. Underside of bracket is unpainted providing a conductive surface to interface with a clean conductive surface on the object or vehicle. After mounting reel check electrical continuity (25 ohms. max.) between object or vehicle and grounding clamps at the end of the cable.

Reel Operation

Extend cable to desired object or earthing ground lug and clamp alligator jaw grip or other grounding connector in place. A pawl and ratchet permits locking of cable at any desired length within the reel's capacity. A simple tug on the cable unlocks the reel for a smooth and steady walk-back retraction.

Perform periodic tests of the bonded object to the ground clamp on the end of the cable grounding reel with Ohm Meter to confirm continuity. Maximum resistance to be 25 ohms. If higher, remove and replace reel. Inspect the entire cable length for kinks and/or broken wires. Inspect the cable clamp for good compression force and/or damage.

Caution: Do not use any part of the electrical current carrying system as a ground for static grounding. Arcing and fires could occur from current feedback where static control grounds are tied into the electrical system neutral.

WARNING:

This product can aid in the discharge of static electricity. No prediction or advice, however, can be given about all the different conditions which can cause static discharges to accumulate. Moreover, it can not be guaranteed that the use of this product (without other precautionary steps) will prevent static ignited fires or explosions which may result in serious injury or death.

SEEK PROFESSIONAL ADVICE BEFORE INSTALLING AND / OR USING THIS PRODUCT.

ASSEMBLY NO. 10-100110

MAJOR ASSEMBLY - MISC. FIXTURES

Sub Assy.	Item	Part No.	Quantity	Description	Wt.#
08-1012				Drain Assembly	
	1A	04-10321	1	Ball Valve	6
	1B	04-1033	1	Camlock Adaptor	1.5
	1C	04-10331	1	Camlock Plug	.5
	1D	04-1034	1	Safety Chain	.2
	1E	04-1034	1	S-Hook, Safety Link	.1
	1F	04-1035	1	S-Hook, Safety Link	.1
08-1013				Grounding Reel Assembly	
	2	04-10361	1	Grounding Reel	12
	2A	04-1036	1	Grounding Reel	12
	2B	02-10040	4	Bolts	.3
	2C	02-12041	4	Nuts	.1
08-1014	3			Sight Gauge Assembly	
	3A	03-0017S	2	Elbow	.5
	3B	03-1007	1	Tee	.5
	3C	03-1008	2	Nipple	.5
	3D	03-11130	2	Hose Barb	1
	3E	03-1010	2	Hose Clamp	.1
	3F	04-1032	1	Ball Valve	2.7
	3G	06-2527	1	Tubing	.1
	5	04-1037	1	Vent	3

SECTION 5.8

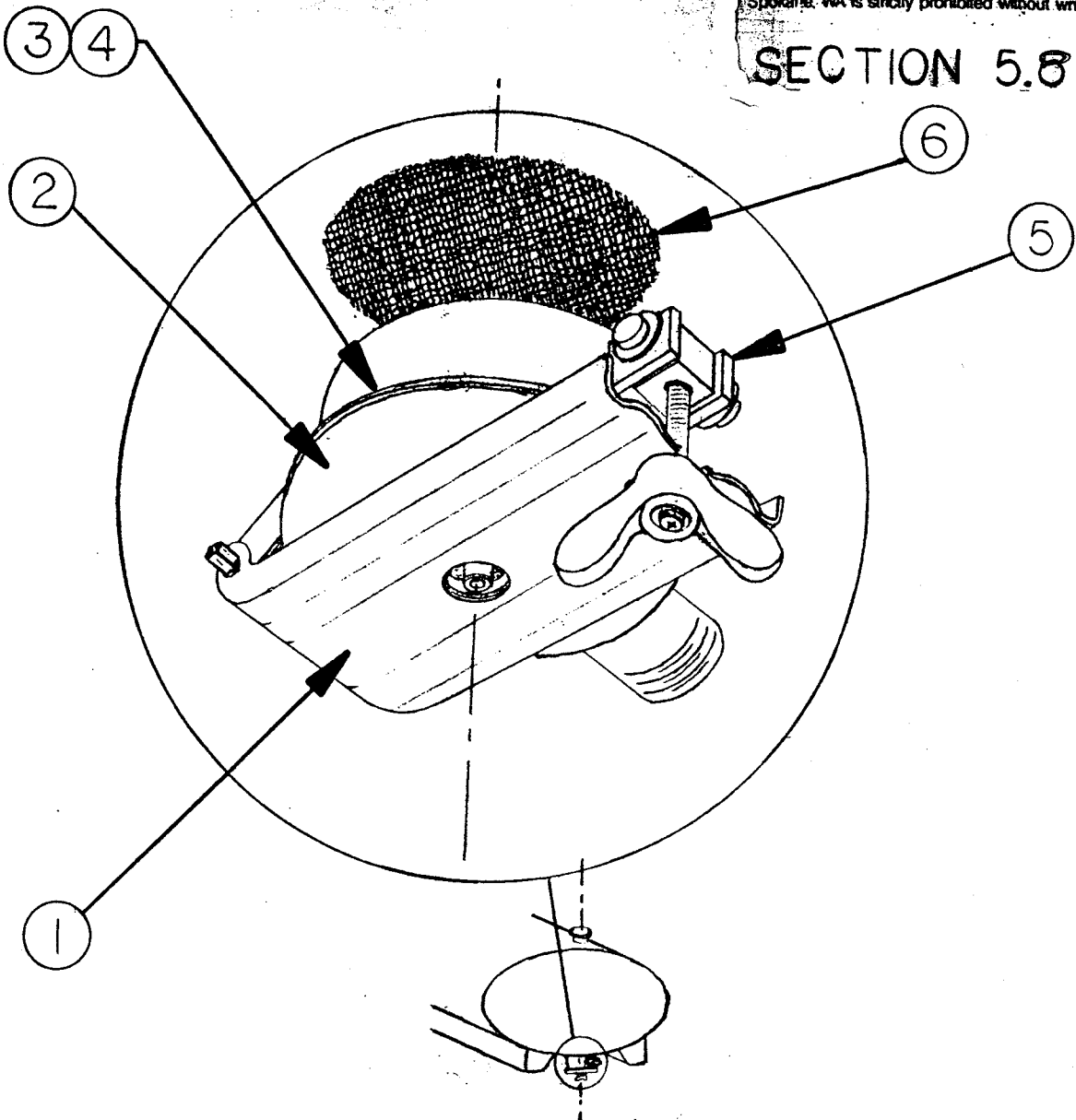

ASSEMBLY 07-1035

MAJOR ASSEMBLY - DRAIN SUMP ASSEMBLY

07-1035				DRAIN SUMP ASSEMBLY, 6"	12.4
	1	04-10581	1	REPAIR KIT INCLUDES ITEMS 2, 3, 4 & 5	6.3
	2	04-125252	1	COVER	2.3
	3	06-1058	1	GASKET, BLACK BUNA N	.4
	4	04-12637	1	GASKET RETAINER	1.4
	5	04-11162	1	PIVOTING WING NUT ASSY	2.1
	6	01-8223	1	SUMP STRAINER SCREEN	.1

CONFIDENTIAL PROPRIETARY INFORMATION
 Reproduction of this data or the manufacturing of products from
 this data by anyone other than Spokane Metal Products of
 Spokane WA is strictly prohibited without written consent

SECTION 5.9

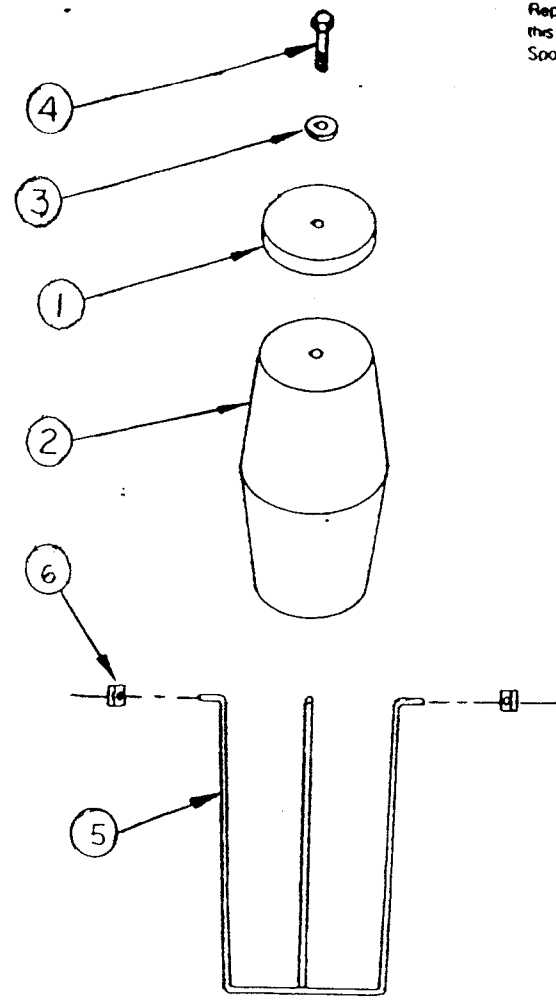

ASSEMBLY NO. 08-1001
 MAJOR ASSEMBLY - VENT, OVERFLOW PREVENTOR

Sub Assy.	Item	Part No.	Quantity	Description	Wt. #
08-1022				Float Assembly	
	1	04-1047	1	Gasket	1
	2	06-1013	1	Float	.5
	3	02-1100	1	Washer	.1
	4	02-10001	1	Bolt	.1
08-1023				Cage Assembly	
	5	07-1032	2	Wire Cage	.9
	6	02-12140	4	Nut	.1

OPERATOR'S MANUAL

INCLUDING: OPERATION, INSTALLATION & MAINTENANCE

650709-C

650717-C

RELEASED: 10-5-89

REVISED: 9-25-93

(REV.C) IPP/PSE

1" DIAPHRAGM PUMP U.L. LISTED, 1:1 RATIO (METALLIC)

**IMPORTANT: READ THIS MANUAL CAREFULLY BEFORE INSTALLING,
OPERATING OR SERVICING THIS EQUIPMENT.**

THIS MANUAL COVERS THE FOLLOWING MODELS

MODEL	TH'D	DIAPHRAGM MATERIAL	APPLICATION
650709-C	NPT	BUNA "N"	Diesel Fuel, Kerosene, Aviation Fuel, Fuel Oil
666717-C	NPT	VITON	Unleaded Fuel

SERVICE KITS

637118-C for Air Section repair. (See page 6.)
637137-62 for repair of Model 650709-C Fluid Section.
637137-63 for repair of Model 650717-C Fluid Section.

PUMP DATA

MODELS - 650709-C, 650717-C
PUMP TYPE - U.L. Listed Metallic Air Operated Double Diaphragm
for use with Petroleum Product Dispensing Systems
MATERIAL - Aluminum Center Body, Fluid Caps and Manifolds
WEIGHT - 18.5 lbs
MAXIMUM AIR INLET PRESSURE - 50 p.s.i. (3.5 bar)
MAXIMUM OUTLET PRESSURE - 50 p.s.i. (3.5 bar)
MAXIMUM FLOW RATE (FLOODED INLET) 0-14 g.p.m.
MAXIMUM PARTICLE SIZE - 1/8" dia.
MAXIMUM TEMP. LIMITS - PVDF 10°F to 200°F (Seats)
DIMENSIONAL DATA - See page 8.

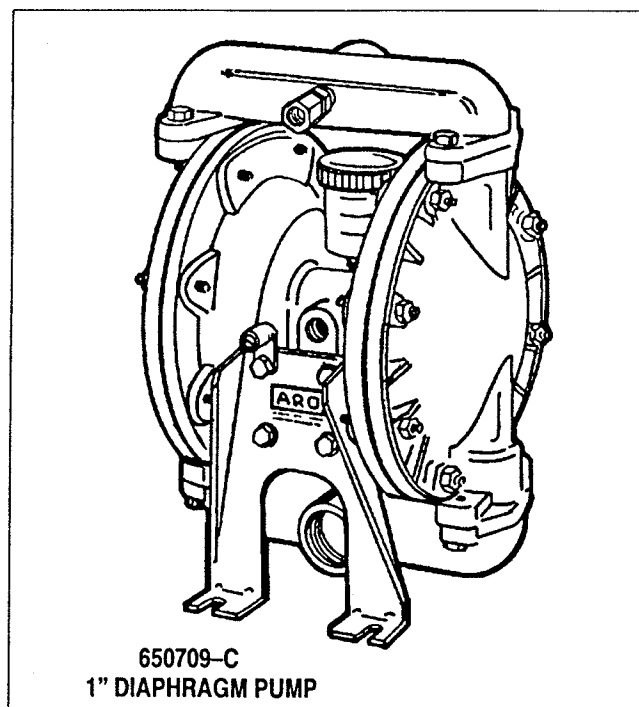

GENERAL DESCRIPTION

The ARO U.L. Listed pump for pumping petroleum products offers high volume delivery at low air pressures and easy self-priming. This model is designed specifically for the transfer, bulk un-loading or fueling

applications. It includes a pressure relief valve (per U.L. Specification 79) which restricts the fluid outlet pressure to under 50 PSI (3.5 bar). The relief valve can be plumbed to return the bleed off fuel to the storage container.

THE ARO CORPORATION • ONE ARO CENTER • BRYAN, OHIO 43506-0151
PH: (419) 636-4242 • FAX (419) 636-2115
©1993 THE ARO CORPORATION • PRINTED IN U.S.A.



Part of worldwide Ingersoll-Rand

OPERATING AND SAFETY PRECAUTIONS

- ▲ Read and heed all Warnings, Cautions, and Safety Precautions before operating this pump.
- ▲ Use only genuine ARO replacement parts to assure compatible pressure rating and longest service life.
- ▲ **WARNING: EXCESSIVE AIR PRESSURE. CAN CAUSE PUMP AND PROPERTY DAMAGE. DO NOT EXCEED THE MAXIMUM INLET AIR PRESSURE AS STATED ON THE PUMP MODEL PLATE.**
- ▲ **WARNING: STATIC SPARK. FAILURE TO SAFEGUARD AGAINST STATIC SPARK, OPEN FLAME, HEAT AND IMPROPER VENTILATION COULD RESULT IN FIRE OR EXPLOSION CAUSING SEVERE PERSONAL INJURY AND/OR PROPERTY DAMAGE. THE PUMP MUST BE GROUNDED WHEN IT IS PUMPING, FLUSHING, OR RECIRCULATING INFLAMMABLE SUBSTANCES SUCH AS: PAINTS SOLVENTS, LACQUERS, ETC. OR USED IN A LOCATION WHERE SURROUNDING ATMOSPHERE IS CONDUCIVE TO SPONTANEOUS COMBUSTION.**
 - Use the pump grounding lug provided on metallic pumps for connection of a 12 ga. (min.) wire to a good earth ground source.
 - Ground dispensing valve or device, containers, hoses and any object to which material is being pumped.
 - After grounding, periodically verify continuity of electrical path to ground. Test with an ohmmeter from each component (e.g., hoses, pump, clamps, container, spray gun, etc.) to ground to insure continuity. Ohmmeter should show 10 ohms or less.
 - Secure pump, connections and all contact points to avoid vibration and generation of contact or static spark.
 - Consult local building codes and electrical codes for specific grounding requirements.
- ▲ **WARNING: DIAPHRAGM RUPTURE. CAN CAUSE SERIOUS INJURY OR PROPERTY DAMAGE. MATERIAL CAN BE FORCED OUT OF THE AIR EXHAUST MUFFLER.**
 - Pipe the exhaust to a safe remote location when pumping hazardous or inflammable materials.
 - Use a grounded 3/8" min. I.D. hose between the the pump and the muffler.
- ▲ **WARNING: HAZARDOUS PRESSURE. CAN RESULT IN SERIOUS INJURY OR PROPERTY DAMAGE. DO NOT SERVICE OR CLEAN PUMP, HOSES OR DISPENSING VALVE WHILE THE SYSTEM IS PRESSURIZED.**
 - Disconnect air supply line and relieve pressure from the system by opening dispensing valve or device and/or carefully and slowly loosening and removing outlet hose or piping from pump.
- ▲ **WARNING: HAZARDOUS MATERIALS. CAN CAUSE SERIOUS INJURY OR PROPERTY DAMAGE. DO NOT ATTEMPT TO RETURN A PUMP TO THE FACTORY OR SERVICE CENTER THAT CONTAINS HAZARDOUS MATERIAL. SAFE HANDLING PRACTICES MUST COMPLY WITH LOCAL AND NATIONAL LAWS AND SAFETY CODE REQUIREMENTS.**
 - Obtain Material Safety Data Sheets on all materials from the supplier for proper handling instructions.
- ▲ **SAFETY PRECAUTIONS (GENERAL)** should include:
 - Use of static wire hoses.
 - Submersion of outlet hose end, dispensing valve or device within material being dispensed whenever possible. (Avoid free streaming of material being dispensed.)
 - Proper ventilation of area away from heat, open flames and sparks.
 - Keeping inflammables away from heat, open flames and sparks.
 - Keeping containers closed when not in use.
 - Be sure material hoses and other components are able to withstand fluid pressures developed by this pump. Check all hoses for damage or wear. Be certain dispensing device is clean and in proper working condition.
- ▲ **CAUTION:** Verify the chemical compatibility of the pump wetted parts and the substance being pumped, flushed or recirculated. Chemical compatibility may change with temperature and concentration of the chemical(s) within the substances being pumped, flushed or circulated. Consult ARO Form No. 8677-P, Fluid Compatibility Guide, for information on chemical compatibility.
- ▲ **CAUTION:** Maximum temperatures are based on mechanical stress only. Certain chemicals will significantly reduce maximum safe operating temperature. Consult Fluid Compatibility Guide for chemical compatibility and temperature limits.
- ▲ **CAUTION:** Be certain all operators of this equipment have been trained for safe working practices, understand it's limitations, and wear safety goggles/equipment when required.
- ▲ **CAUTION:** Do not use the pump for the structural support of the piping system. Be certain the system components are properly supported to prevent stress on the pump parts.
 - Suction and discharge connections should be flexible connections (such as hose), not rigid piped, and should be compatible with the substance being pumped.
- ▲ **CAUTION:** Prevent unnecessary damage to the pump. Do not allow pump to operate when out of material for long periods of time.
 - Disconnect air line from pump when system sits idle for long periods of time.

AIR AND LUBE REQUIREMENTS

▲ **WARNING: EXCESSIVE AIR PRESSURE CAN CAUSE PUMP AND PROPERTY DAMAGE. THE AIR SUPPLY MUST BE LIMITED TO 50 PSIG (3.5 BAR) MAXIMUM INLET AIR PRESSURE.**

- The air supply line or hose to the pump should be adequately sized to carry a sufficient volume of air to the pump. The material inlet supply tubing should not be too small or restrictive which will inhibit material flow. The outlet material volume is governed not only by the air supply but also by the material volume available at the inlet.
- Air supply provided should be filtered to provide clean dry air. A filter capable of filtering out particles larger than 50 microns should be used on the air supply. In most applications there is no lubrication required other than the "O"ring lubricant which is applied during assembly or repair.
- When lubricated air is necessary, supply the air lubricator with a good grade of SAE 90 wt. non-detergent oil and set the lubricator to a rate not to exceed one drop per minute.

INSTALLATION

IMPORTANT

- Requirements for the installation are included in the flammable and combustible liquids code, ANSI/NFPA No. 30 and the National Electric Code, ANSI/NFPA No. 70.
- A fluid return hose which is compatible with the fluid being pumped must be installed to the relief valve on the outlet manifold to return fluid back to the supply tank or pump inlet.
- The pump must be grounded to prevent static discharge. Grounding may be accomplished through the legs or to the ground lug provided on the pump.
- Notice that the material inlet/outlet manifolds may be removed and rotated 180° to facilitate various mounting applications.
- If the body of the pump must be rotated remove the end covers and manifolds and index it so the bolts line up properly. NOTE: The arrow on the end caps must always point upward for optimum performance.
- When the Diaphragm Pump is used in a force-feed situation it is recommended that a Check Valve be installed at the air inlet to keep material out of air line in the event of diaphragm failure.
- Secure diaphragm pump legs to a suitable surface to insure against damage by excessive vibration.

OPERATING INSTRUCTIONS

- The pump should never be operated at pressures exceeding 50 PSIG inlet air pressure. This pump is equipped with a pressure relief valve on the material outlet manifold which will open at 45+/-4 PSI to relieve pressure increases in the outlet hoses/plumbing caused by thermal expansion or other external forces.
- Disconnect the air supply from the pump if it is to be inactive for a few hours.

MAINTENANCE

Refer to the part views and descriptions as provided on page 4 through 7 for parts identification and Service Kit information.

- Certain ARO "Smart Parts" are indicated which should be available for fast repair and reduction of down time.
- Service kits are divided to service two separate diaphragm pump functions: 1. AIR SECTION, 2. FLUID SECTION. The FLUID SECTION is divided further to match typical part MATERIAL OPTIONS.
- Provide a clean work surface to protect sensitive internal moving parts from contamination from dirt and foreign matter during service disassembly and reassembly.
- Keep good records of service activity and include pump in preventive maintenance program.
- Before disassembling empty captured material in the outlet manifold by turning the pump upside down to drain material from the pump.

• Viton®, Teflon®, and Hytrel® are trademarks of the DuPont Company. • Kynar® is a trademark of Penwalt Corp.
• Santoprene® is a registered trademark of Monsanto Company, licensed to Advanced Elastomer Systems, L.P. • Key-Lube is a trademark of Key Industries.

PARTS LIST / FLUID SECTION

FLUID SECTION SERVICE KITS

✓ KITS INCLUDE: (22) BALLS, (7) DIAPHRAGM, items: 2, 3, 9, 19, (Refer to chart below) and 93706-1 Key-Lube grease.

MATERIAL CODE

[A]=Aluminum
 [B]=Buna "N"
 [BR]=Brass
 [C]=Carbon Steel
 [D]=Acetal
 [K]=P.V.D.F. (Kynar)
 [N]=Neoprene
 [S]=Steel
 [SS]=Stainless Steel
 [T]=Teflon
 [V]=Viton

WETTED COMMON PARTS

ITEM	DESCRIPTION (SIZE IN INCHES)	QTY	650709-C (BUNA)		650717-C (VITON)	
			PART NO.	[MT]	PART NO.	[MT]
	Fluid Section Service Kits		637137-62		637137-63	
□1	Rod	*(1)	98724-1	[C]	98724-1	[C]
✓2	"O"Ring (3/4 O.D.)	(1)	Y330-113	[B]	Y330-113	[B]
✓3	"O"Ring (5/8 O.D.)	(4)	92957	[B]	Y327-014	[V]
5	Plate (Air side) (3-3/8 O.D.)	(2)	93441-2	[S]	93441-2	[S]
□6	Plate (Fluid side) (3-3/8 O.D.)	(2)	93441-2	[S]	93441-2	[S]
✓7	Diaphragm	(2)	90533-2	[B]	90533-3	[V]
✓9	Washer (5/8)	(2)	93189-1	[SS]	93189-1	[SS]
14	Screw	(2)	Y5-85-K	[S]	Y5-85-K	[S]
15	Fluid Cap	(2)	92002	[A]	92002	[A]
16	Manifold (Top w/valve port)	(1)	93127	[A]	93127	[A]
	Manifold	(1)	92001	[A]	92001	[A]
✓19	"O"Ring (1-9/16 O.D.)	(4)	92961	[B]	Y327-126	[V]
21	Seat	(4)	92941	[K]	92941	[K]
✓22	Ball	(4)	90532-6	[D]	90532-6	[D]
26	Bolt (5/16-18 x 1)	(8)	Y6-55-C	[S]	Y6-55-C	[S]
29	Nut (5/16-18)	(16)	Y12-5-C	[S]	Y12-5-C	[S]
43	Ground Lug	(1)	93004	[S]	93004	[S]
	Pressure Relief Valve (See Pg. 8)	(1)	93130	[BR]	93130	[BR]

Service Note: Part No. 98930-T Installation Tool is available separately for use with items (1) and (2).

*Service Kit Note: Extra O-rings are included in kits to service models built prior to Sept. 1989.

FLUID SECTION DISASSEMBLY

1. Remove top manifold(s).
2. Remove (22) balls, (19) "O"rings, (21) seats.
3. Remove (15) fluid caps.
4. Remove the (14) screw, (9) washer, (3) "O"ring, (6) plate, (7) diaphragms, and (5) plates.
5. Remove (3) "O"Rings.

NOTE: Do not scratch or mar the surface of (1) diaphragm rod.

FLUID SECTION REASSEMBLY

- Reassemble in reverse order.
- Clean and inspect all parts. Replace worn or damaged parts with new parts as required.
- Lubricate diaphragm rod (1) and (2) "O"ring with Key-Lube® "O"ring lube or equivalent.
- Use ARO PN/98930-T Bullet (installation tool) to aid in installation of "O"ring (2) on diaphragm rod (1).
- Be certain (7) diaphragms align properly with (15) fluid caps before making final torque adjustments on bolt and nuts to avoid twisting the diaphragm.
- Re-check torque settings after pump has been re-started and run a while.

□ "Smart Parts" keep these items on hand in addition to the Service Kits for fast repair and reduction of down time.

COLOR CODE		
MATERIAL	DIAPHRAGM COLOR	BALL COLOR
ACETAL	N/A	ORANGE
BUNA	RED (-)	RED (+)
EPR	BLUE (-)	BLUE (+)
HYTREL	CREAM	TAN
NEOPRENE	GREEN (-)	GREEN (+)
SANTOPRENE	GREEN	N/A
TFE	WHITE	WHITE
URETHANE	N/A	RED
VITON	YELLOW (-)	YELLOW (+)
	(-) STRIPE	(+) DOT

FOR THE
AIR MOTOR SECTION
SEE PAGES 6 & 7

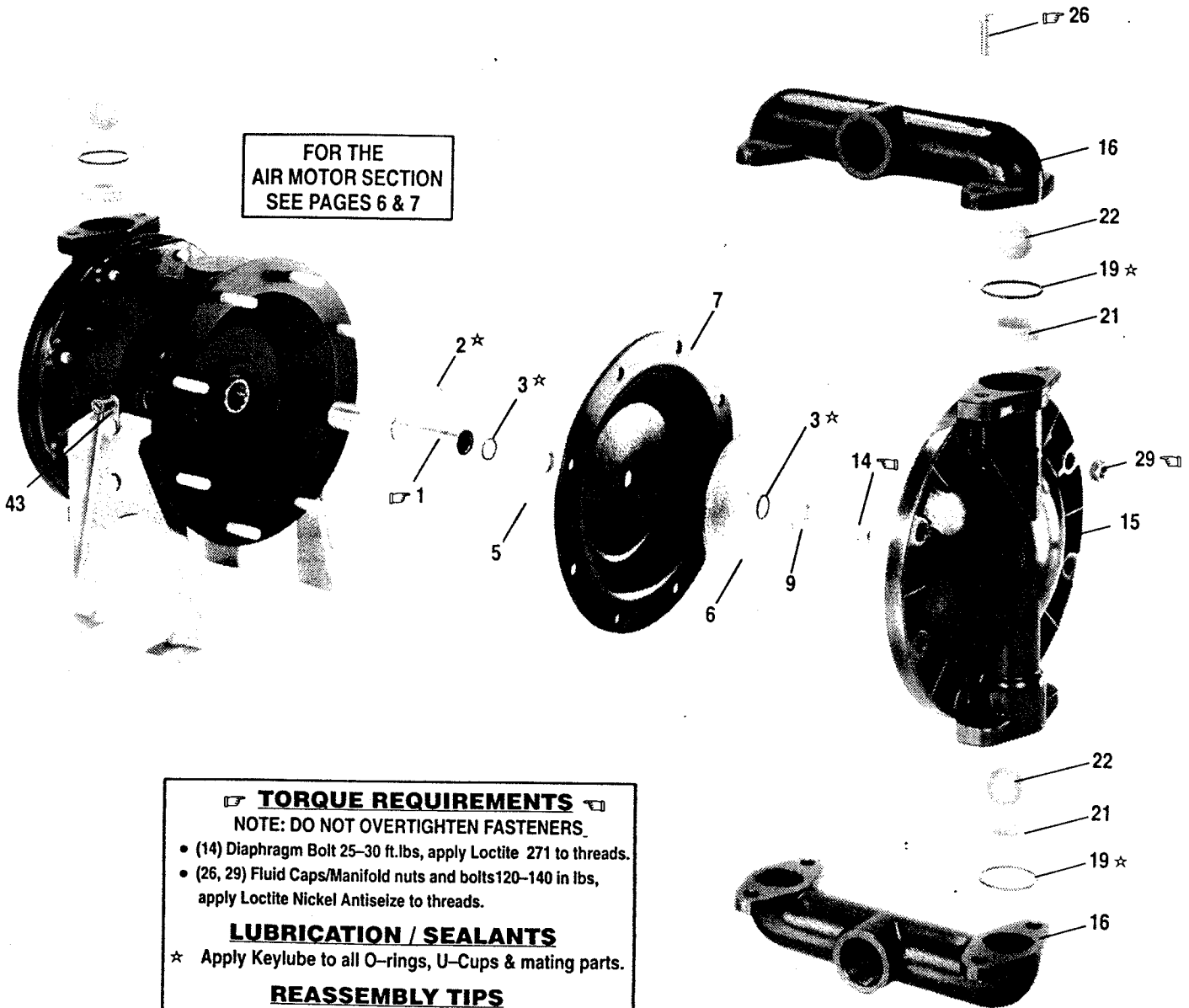

TORQUE REQUIREMENTS
NOTE: DO NOT OVERTIGHTEN FASTENERS.

- (14) Diaphragm Bolt 25–30 ft.lbs, apply Loctite 271 to threads.
- (26, 29) Fluid Caps/Manifold nuts and bolts 120–140 in lbs, apply Loctite Nickel Antiseize to threads.

LUBRICATION / SEALANTS

- ★ Apply Keylube to all O-rings, U-Cups & mating parts.

REASSEMBLY TIPS

- (5) & (6) Washer radius is towards Diaphragm.
- (8) I.D. bevel is towards (3) O-ring.

PARTS LIST / AIR SECTION

✓ Indicates parts included in 637118-C Air Section Service Kit.

ITEM	DESCRIPTION (Size in Inches)	QTY	PART NO.	[MTL]
101	Motor Body	(1)	66836-1	[A]
□102	O-Ring (1 O.D.)	(1)	92959	[B]
□103	Sleeve	(1)	98722-1	[BZ]
✓104	Retaining Ring, TruArc (13/16 O.D.)	(2)	Y145-25	[S]
105	Cap Screw (1/4-20 x 5/8)	(8)	Y6-42-C	[S]
106	Lockwasher (1/4)	(7)	Y14-416	[S]
107	Leg	(2)	92003	[C]
✓108	Gasket (With Notch)	(1)	92878	[B/NY]
□109	Piston	(1)	92011	[D]
✓110	U-Cup (1-3/8 O.D.)	(1)	Y186-51	[B]
□111	Spool	(1)	92005	[A]
112	Washer (1.557 O.D.)	(5)	92877	[Z]
✓113	O-Ring (Small) (1-1/4 O.D.)	(5)	Y325-214	[B]
✓114	O-Ring (Large) (1-9/16 O.D.)	(6)	Y325-126	[B]
□115	Spacer	(4)	92876	[Z]
□116	Spacer	(1)	92006	[A]

ITEM	DESCRIPTION (Size in Inches)	QTY	PART NO.	[MTL]
✓117	Gasket	(1)	92004	[B/NY]
118	Pilot Rod	(1)	93309-1	[C]
✓119	O-Ring (3/4 O.D.)	(4)	93075	[U]
120	Spacer	(3)	115959	[Z]
121	Sleeve Bushing	(2)	98723-1	[BZ]
✓122	O-Ring (1/2 O.D.)	(2)	Y330-110	[B]
✓123	Screw (8-32 x 3/8)	(4)	Y154-41	[S]
124	Stud (5/16-18 x 1-3/4)	(16)	92866	[SS]
128	Pipe Plug (1/8)	(1)	Y17-50-C	[S]
201	Muffler	(1)	93110	[P]
✓	Keylube, O-Ring Lubricant	(1)	93706-1	
	10 Pak of Keylube		637175	

AIR MOTOR SECTION SERVICE

Service is divided into two parts – 1.Pilot Valve, 2.Major Valve.
GENERAL REASSEMBLY NOTES:

- Air Motor Section Service is continued from Fluid Section repair.
- Inspect and replace old parts with new parts as necessary. Look for deep scratches on metallic surfaces, and nicks or cuts in "O"rings.
- Take precautions to prevent cutting "O"rings upon installation.
- Lubricate "O"rings with Key-lube or equivalent.
- Do not over-tighten fasteners, refer to torque requirement block on view.
- Re-torque fasteners following restart.

PILOT VALVE DISASSEMBLY

1. Remove (104) retaining ring.
2. Remove, (123) screws, (122)"O"rings.
3. Remove (118) piston rod, (121) sleeve bushing, (119) "O"rings, and (120) spacers from the (101) motor body.
4. Remove (103) sleeve and (102) "O"ring.

PILOT VALVE REASSEMBLY

1. Replace (102) "O"ring if worn or damaged and reinstall (103) sleeve.
2. Install one of the (121) sleeve bushings, (119) "O"rings, (120) spacers, and the remaining (121) bushing.
3. Carefully push (118) pilot rod into bushings etc. and retain on each end with the two (122) "O"rings, retain with (123) screws.
4. Replace (104) retaining rings.

MATERIAL CODE

[A] = Aluminum	[NY]=Nylon
[B] = Buna -N"	[S] = Steel
[BZ]=Bronze	[SS] = Stainless Steel
[C] = Carbon Steel	[U] = Polyurethane
[D] = Acetal	[Z] = Zinc

MAJOR VALVE DISASSEMBLY

1. Remove (107) legs, (108) and (117) gaskets.
2. On the side opposite the air inlet, push on the inner diameter (111) spool. This will force the (109) piston out. Continue pushing the (111) spool and remove. Check for scratches and gouges.
3. Reach into the air section (exhaust side) and remove (116) spacer, (115) spacers, (113) "O"rings, (114) "O"rings, (112) washers, etc. Check for damaged "O"rings.

MAJOR VALVE REASSEMBLY

NOTE: Replace worn parts as necessary. Lubricate "O"ring with Key-Lube "O"ring lube or equivalent when reassembling.

1. Replace (112) washer, (114) "O"ring, (113) "O"ring onto (115) spacer and insert etc.

NOTE: Be careful to orient spacer legs away from blocking internal ports.

2. Lubricate and carefully insert (111) spool.
3. Install (117) gasket and (107).
4. Lubricate and install (110) packing cup and insert (109) piston into (air inlet side) cavity, the (110) packing cup lips should point outward.
5. Install (108) gasket and replace (107).

□"Smart Parts" Keep these items on hand in addition to the Service Kits for fast repair and reduction of down time.

MAJOR VALVE

See cross section detail Figure 3.

IMPORTANT
BE CERTAIN TO ORIENT (115) SPACER LEGS
AWAY FROM BLOCKING INTERNAL PORTS
WHEN REASSEMBLING AIR SECTION.

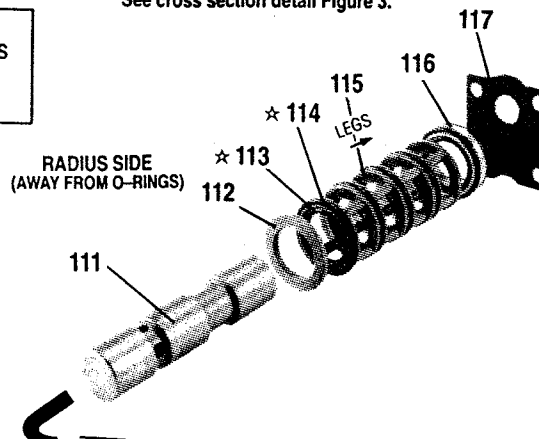
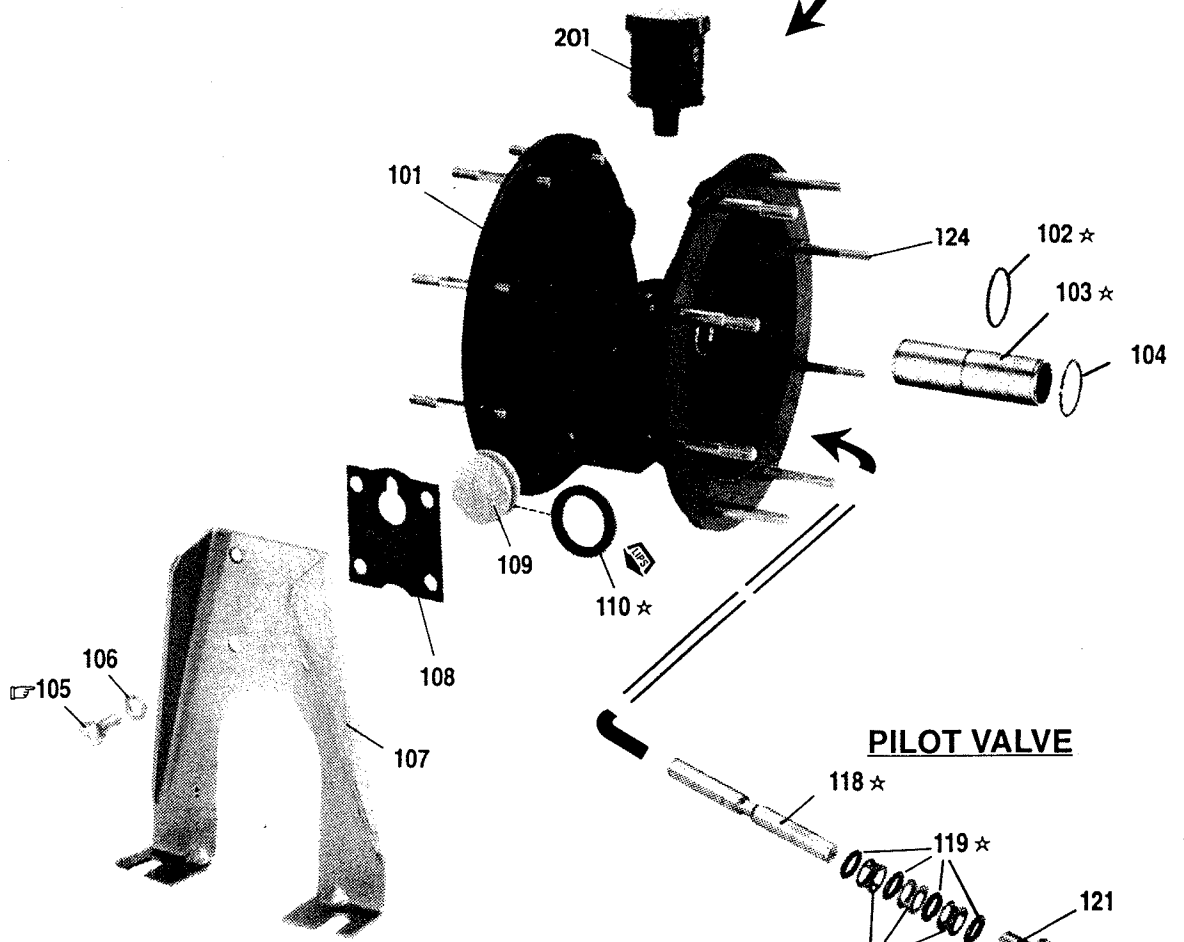

FIGURE 2



PILOT VALVE

MAJOR VALVE CROSS SECTION DETAIL

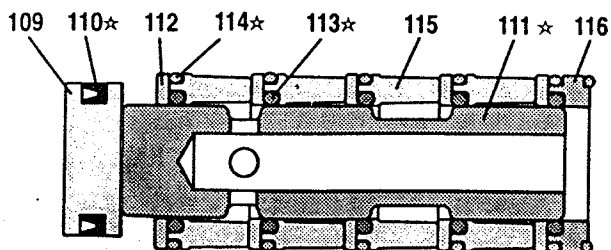

FIGURE 3

TORQUE REQUIREMENTS
NOTE: DO NOT OVERTIGHTEN FASTENERS
(105) 40-50 in. lbs., apply Loctite Nickel Antiseize to threads.

LUBRICATION / SEALANTS
★ Apply Keylube to all O-rings, U-Cups & mating parts.
◆ Apply Loctite 271 to threads.

42

TROUBLE SHOOTING

Product discharged from exhaust outlet.

- Check for diaphragm rupture.
- Check tightness of diaphragm nut.

Air bubbles in product discharge.

- Check connections of suction plumbing.
- Check "O" rings between intake manifold and fluid caps.
- Check tightness of diaphragm nut.

Low output volume, erratic flow, or no flow.

- Check air supply.
- Check for plugged outlet hose.
- Check for kinked (restrictive) outlet material hose.
- Check for kinked (restrictive) or collapsed inlet material hose.
- Check for pump cavitation – suction pipe should be sized at least as large as the inlet thread diameter of the pump for proper flow if high viscosity fluids are being pumped. Suction hose must be a non-collapsing type, capable of pulling a high vacuum.
- Check all joints on the inlet manifolds and suction connections. These must be air tight.
- Inspect the pump for solid objects logged in the diaphragm chamber or the seat area.

DIMENSIONAL DATA

(Dimensions shown are for reference only, they are displayed in inches and millimeters (mm).)

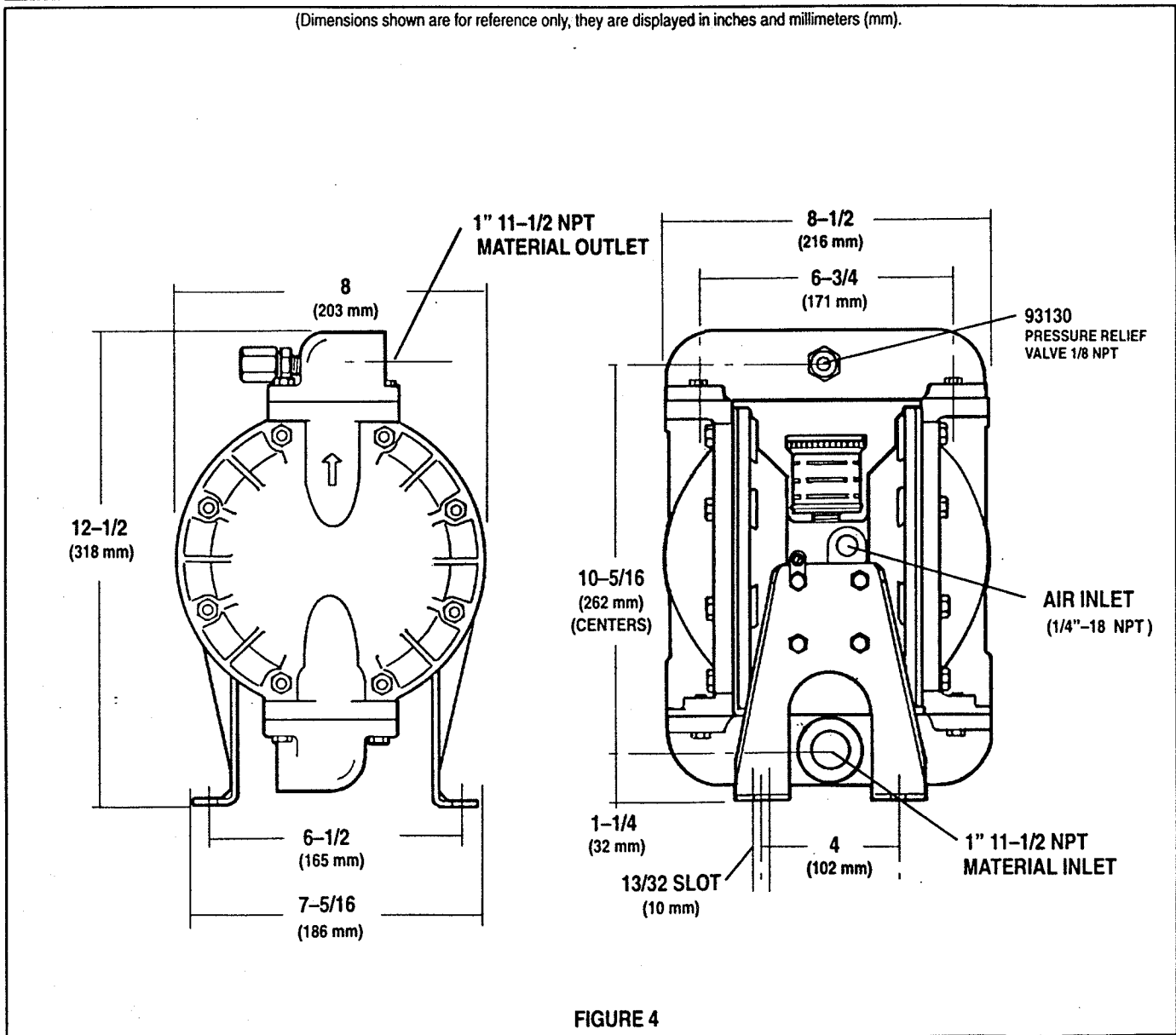

FIGURE 4



Part of worldwide Ingersoll-Rand

SPOKANE METAL PRODUCTS

Spokane Washington

200 GALLON BOWSER FUEL DRAIN TANK

ONE YEAR LIMITED WARRANTY

Seller warrants its 200 Gallon Bowser Fuel Drain Tank to be free from defects in material and workmanship under the normal use and service for which the unit is intended if, but only if the unit has been properly operated, maintained and stored in accordance with printed directions contained in the product manual. Our obligation under this Warranty shall be limited to the repair or exchange of equipment and parts which may prove defective within one year of the date the unit is put into service but shall in no event extend beyond a date two years from the date the unit is shipped from our plant. All transportation charges on parts returned to us for replacement under this warranty must be returned pre-paid.

This warranty does not extend to damage caused by environmental factors varying from normal design conditions, whether natural or man-made, or to units subjected to misuse, negligence or accident. This warranty likewise does not extend to the unit or any parts thereof which have been repaired or altered improperly or in any way so as to effect adversely its stability or reliability. This warranty does not cover parts or labor required to repair or replace parts whose usefulness is exhausted due to normal operation of the unit.

THIS WARRANTY IS EXPRESSLY IN LIEU OF ALL OTHER WARRANTIES, EXPRESS OR IMPLIED, INCLUDING ANY IMPLIED WARRANTY OF MERCHANTABILITY OR FITNESS FOR A PARTICULAR PURPOSE NOT SET FORTH IN A WRITING SIGNED BY AN AUTHORIZED REPRESENTATIVE OR SELLER. SELLER SHALL IN NO EVENT BE LIABLE FOR ANY CONSEQUENTIAL LOSS OR DAMAGE RESULTING FROM THE USE OR LOSS OF USE OF THE UNIT.

SPOKANE METAL PRODUCTS

Spokane Washington

CONFIDENTIAL PROPRIETARY INFORMATION
Reproduction of this data or the manufacturing of products from
this data by anyone other than Spokane Metal Products of Spokane
Washington is strictly prohibited without written consent

200 GALLON FUEL BOWSER

TECHNICAL MANUAL

PARTS, OPERATION AND MAINTENANCE

MODEL NUMBER BOW 200-07

© COPYRIGHT 1991 By SPOKANE INDUSTRIES INC.
ALL RIGHTS RESERVED

This document discloses subject matter in which Spokane Metal Products has Proprietary rights and such subject matter shall not, without the written permission of Spokane Metal Products, be either (A) used, released or disclosed in whole or in part outside the government, (B) used in whole or in part by the government for manufacture, or (C) used by a party other than the government, except for (1) emergency repair or overhaul work only, by or for the government, where the item or process concerned is not otherwise reasonably available to enable timely performance of the work, provided that release or disclosure hereof outside the government shall be made subject to a prohibition against further use, release or disclosure, or (2) release to a foreign government, or for emergency repair or overhaul work by or for such government under the conditions of (1) above. This legend shall be marked on any reproduction hereof in whole or in part.

200 GALLON FUEL BOWSER

TECHNICAL MANUAL

PARTS, OPERATION AND MAINTENANCE

MODEL NUMBER BOW 200-07

INDEX

	<u>Page</u>
<u>Section 1.</u> Introduction	1
<u>Section 2.</u> Safety	1
<u>Section 3.</u> Operation	
3.1 Intended Use	2
3.2 Parking Brake	2
3.3 Tow Bar and Under Carriage	2
3.4 Telescoping Drain Assembly	3
3.5 Vacuum Assembly	4
3.6 Grounding Reels	4
3.7 Drain Valve	5
3.8 Sample Port	5
3.9 Telescoping Drain Strainer	5
3.10 Vent Overflow Preventor	5
<u>Section 4.</u> Maintenance	
4.1 Parking Brake	5
4.2 Under Carriage and Tow Bar	6
4.3 Telescoping Drain Assembly	6
4.4 Vacuum Assembly	6
4.5 Grounding Reels	6
4.6 Sight Gauge	7
4.7 Telescoping Drain Strainer	7
4.8 Vent Overflow Preventor	7

<u>Section 5.</u>	Replacement Parts	9
5.1	Main Tank	10
5.2	Under Carriage	
	Axle, Front	12
	Axle, Rear	15
	Brake, Parking	16
	Wheel Assembly, Front	18
	Wheel Assembly, Rear	20
5.3	Manway Assembly	22
5.4	Decal Package	23
5.5	Telescoping Drain	25
5.6	Vacuum Assembly	28
5.7	Miscellaneous Fixtures	31
5.8	Drain Sump Assembly	34
5.9	Vent, Overflow Preventor	35
5.10	DIAPHRAGM PUMP	36
<u>Warranty</u>	44

1.0 INTRODUCTION

- 1.1 To obtain optimum benefit from your fuel bowser unit, it is recommended that all personnel operating it read and understand this manual prior to operation.
- 1.2 Upon receipt of the Bowser unit, a visual inspection should be made to determine that it is complete and has not sustained any damage during transportation.

2.0 SAFETY

2.1 Potential Fire Or Explosion

2.1.1 Due to the nature of fuel, care should be exercised to eliminate all sparks and open flame in the area of the fuel bowser.

2.1.2 A 50 foot radius area around the fuel bowser for no smoking, sparks, or open flames is usually a good practice. It is strongly recommended all local or other regulations be consulted for further restrictions.

2.2 Telescoping Drain

2.2.1 Care should be exercised in using the telescope to prevent injury fingers between clamps by dropping sections.

2.3 Grounding

2.3.1 To eliminate static sparks, the bowser unit is equipped with two grounding reels which should be connected prior to draining or filling operations.

2.4 Towing

2.4.1 Make sure the tow bar is securely attached to the towing vehicle.

2.4.2 Before moving the bowser unit, check to assure the parking brake is released.

2.4.3 Maximum allowable towing speed is 15 MPH.

2.5 Parking

2.5.1 Parking brake must be applied when filling and draining or when left unattended.

3.3.3 Tire inflation should be checked and maintained as described in the maintenance section.

3.3.4 Before towing, check to see the brake is disengaged, grounding reel and hoses are disconnected, valves are closed, tow bar is securely attached to the towing vehicle, telescoping drain is collapsed, and all manways and covers are closed and latched.

3.3.5 The bowser unit is equipped with a tow bar latch to hold it in the upright position.

3.4 Telescoping Drain Assembly

3.4.1 The fuel bowser is equipped with a telescoping drain assembly. It is capable of being adjusted from 4'2" to 12'0" high.

3.4.2 To Raise:

- (1) Loosen top clamp if necessary.
- (2) Grasp top section with one hand and lift until the top clamp raises approximately 6 inches.
- (3) Tighten clamp securely with the other hand.
- (4) Reposition lifting hand by grasping tube below tightened clamp and lift until next clamp is raised approximately 6 inches.
- (5) Repeat steps 1-4 until desired height is obtained or assembly is fully extended.

3.4.3 To Lower:

- (1) Tightly grasp bottom extended tube with one hand and loosen the securing clamp.
- (2) Slowly lower tube, hand over hand, until the following clamp is resting on the loosed clamp.
- (3) Repeat steps 1 and 2 until all sections are lowered.

3.4.4 Funnel is equipped with a nitrile rubber seal around the top edge to allow placement against the underside of a wing.

3.4.5 When not in use, telescope should be collapsed and the cover closed to eliminate contamination.

3.5 Vacuum Assembly

3.5.1 This assembly is equipped with an air powered vacuum generator.

3.5.2 It is intended for vacuum draining or depuddling fuel and condensation. Caution! If other objects such as rock or metallic pieces are vacuumed into the vacuum chamber, they may create a hazard due to sparks.

3.5.3 Vacuum is started by attaching a recommended air supply of 60CFM at 100 PSI and turning on the air supply valve.

3.5.5 The vacuum generator is equipped with an automatic overflow protector. When the level of product is full, the valve shuts off and eliminates the vacuum.

3.5.6 The vacuum assembly is supplied with 50 feet of vacuum hose and a ball valve on the vacuum suction.

3.5.7 The vacuum assembly is equipped with (4) four each 1/2" NPT opening for use with pencil drains. To use, the pipe caps must be removed and self-closing quick disconnects attached that match local standards. To operate, close vacuum suction valve and turn air supply on and connect drain lines.

3.6 Grounding Reels

3.6.1 The bowser unit is supplied with two grounding reels.

3.6.2 Before filling, draining, or vacuuming, the grounding reels must be attached to the aircraft or object being serviced and an appropriate ground.

3.7 Drain Valves

3.7.1 The bowser unit is equipped with a 1-1/2" NPT ball valve with a camlock connector.

3.8 Sample Port

3.8.1 The bowser unit is equipped with a 1/2" NPT valve for use as a sample port.

3.9 Telescoping Drain Strainer

3.9.1 The bowser unit is equipped with a sump with removable bottom to allow cleaning of the drain strainer.

3.10 Vent Overflow Protector

3.10.1 The bowser unit is equipped with a float actuated seal to prevent fuel from flowing out the vent in the event the bowser is overfilled.

4.0 MAINTENANCE

4.1 Parking Brake

4.1.1 The bowser unit is equipped with a parking brake assembly consisting of a 7" diameter brake drum with 2-1/4" wide brake shoes.

4.1.2 The shoes are activated via a mechanical linkage, eccentric and lever.

4.1.3 Adjustment may be necessary as the shoes wear.

- (1) Tightening is accomplished by removing the bolt through one yoke and screwing yoke in to shorten connecting rod.
- (2) Do not over tighten or brakes may drag when released.

4.1.4 Replacement of shoes.

- (1) Remove wheel.
- (2) Remove nut retaining hub and drum assembly.
- (3) Disconnect actuating rod.
- (4) Remove shoe retainers.
- (5) Install new shoes.
- (6) Replace shoe retainers.
- (7) Adjust actuator rod length.
- (8) Replace wheel.

4.2 Under Carriage and Tow Bar

4.2.1 The bowser unit is equipped with steerable front wheels, fixed rear wheels, and a tow bar.

4.2.2 Maintenance should consist of the following:

- (1) King pin bushing, turning bushings and tie rod ends are self lubricating and need no additional maintenance.
- (2) Pack wheel bearing at intervals not to exceed three (3) months.
- (3) Check tire pressure weekly. Pressure should be maintained at 60 PSI.

4.2.3 Tow bar pivot pin and hook ring should be inspected monthly for excessive wear or cracks.

4.3 Telescoping Drain Assembly

4.3.1 The telescoping Drain Assembly consists of stainless steel housing 4" in diameter permanently attached to the tank and four aluminum tube sections.

4.3.2 The stainless tube and four largest aluminum tubes are equipped with a clamp assembly.

4.3.4 Each aluminum tube is crimped on the lower end which acts as a stop to prevent the tube from sliding through the clamp.

4.3.5 Disassembling of the telescope assembly is accomplished by rotating the four sections 180 degrees from normal position and gently lifting each section so that the crimped edge on the tube is aligned with the slot on the clamp.

4.4 Vacuum Assembly

4.4.1 The vacuum assembly consists of a vacuum chamber with an air powered vacuum generator mounted on a removable cover. The cover is held in place by three (3) eccentric latches.

- 4.4.3 The vacuum cover is equipped with an overflow valve which should require no maintenance.
- 4.4.4 The vacuum generator is attached to the chamber cover. It is equipped with an exhaust silencer which should be cleaned at six (6) month intervals or more often depending on the amount of use and conditions.
- 4.4.5 The vacuum hose should be inspected monthly for cracks. Any sudden loss of vacuum suction power may indicate a crack in the vacuum hose.
- 4.4.6 The cover gasket should be inspected monthly for deterioration. This gasket should be pliable and free from weather checking.
- 4.4.7 The overflow stop pivot bolts should not be overtightened. Over tightening will restrict motion of the floats.
- 4.5 Grounding Reels
- 4.5.1 Grounding reel cables should be pulled out, cleaned and inspected monthly.
- 4.5.2 Cable clamps and ends should be inspected for loose connections monthly.
- 4.6 Sight Gauge
- 4.6.1 The sight gauge should be inspected monthly for loose connections and weathering of clear tubing.
- 4.7 Telescoping Drain Strainer
- 4.7.1 Telescoping drain strainer is located on the bottom of the stainless steel drain housing.
- 4.7.2 Maintenance should consist of inspection and cleaning monthly.
- 4.7.3 Removal:
- (1) Removal is accomplished by loosening the wing nut on the clamp holding the base of the sump. NOTE! Check interior to assure fuel has been thoroughly drained before loosening wing nut.
 - (2) Remove clamp and sump base.
 - (3) Loosen clamp holding screen to stainless steel drain housing and pull screen down.
- 4.8 Vent Overflow Preventor
- 4.8.1 The vent overflow preventor is located inside the tank directly under the vent.
- 4.8.2 It consists of a caged float with an elastomer seal.

4.9 TROUBLE SHOOTING

<u>SYMPTOM</u>	<u>PROBABLE CAUSE</u>	<u>PROBABLE CORRECTIONS</u>
Bowser does not track or steer correctly or steers loosely	Bent King Pin housing see section 5.2.1 Item #7	Replace King Pin housing
	Defective Tie Rod End see section 5.2.1 Item #12	Replace Tie Rod End
	Loose or worn out Bushings, see section 5.2.1 Items #11,16 or 18	Replace as needed
Toe Bar does not stay in the upright position	Broken or stretched spring see section 5.2.1 Item # 26	Replace as needed
Parking Brake does not work	Need adjustment	Adjust as per instructions in section 4.1.0
	Needs repairing see section 5.2.3	Replace as needed
Vacuum System does not have much suction	Defective lower drain stop gasket, see section 5.6 Item #2	Replace as needed
	Not enough air pressure to operate vacuum generator, see section 3.5.3 and 4.4	Increase air pressure and volume
	Plugged outlet Filter see section 5.6	Replace or clean as required
Fuel misting is occurring through vacuum generator	Bowser tank is to full	Empty main Bowser tank
	Overflow stop gasket needs replacing or adjusting, see section 3.5.0 and 5.6	Replace or adjust as needed
	Float on Vacuum shut-off is bent, see section 5.6	Fix or repair as needed

<u>SYMPTOM</u>	<u>PROBABLE CAUSE</u>	<u>PROBABLE CORRECTIONS</u>
----------------	-----------------------	-----------------------------

Telescoping Drain won,t stay up	Loose clamp handles	Tighten handles a little tighter
	Worn Sleeve Clamp Liners, see section 5.5	Replace as needed

Telescoping Drain is over flowing	Bowser tank is full	Empty main Bowser tank
	Clogged screen or strainer, see section 4.7 and or 5.5	Remove and clean as required

5.0 REPLACEMENT PARTS

This section provides information for identification of parts for ordering. To order, it is important to have the Model Number, Subassembly Number, Part Number and Description. Parts may be ordered by calling or writing to:

SPOKANE METAL PRODUCTS
P.O. Box 3303
Spokane, WA 99220-3303
Telephone: (509)928-0720
Tele Fax:(509)927-0826

CONFIDENTIAL PROPRIETARY INFORMATION
 Reproduction of this data or the manufacturing of products from
 this data by anyone other than Spokane Metal Products of
 Spokane, WA is strictly prohibited without written consent.

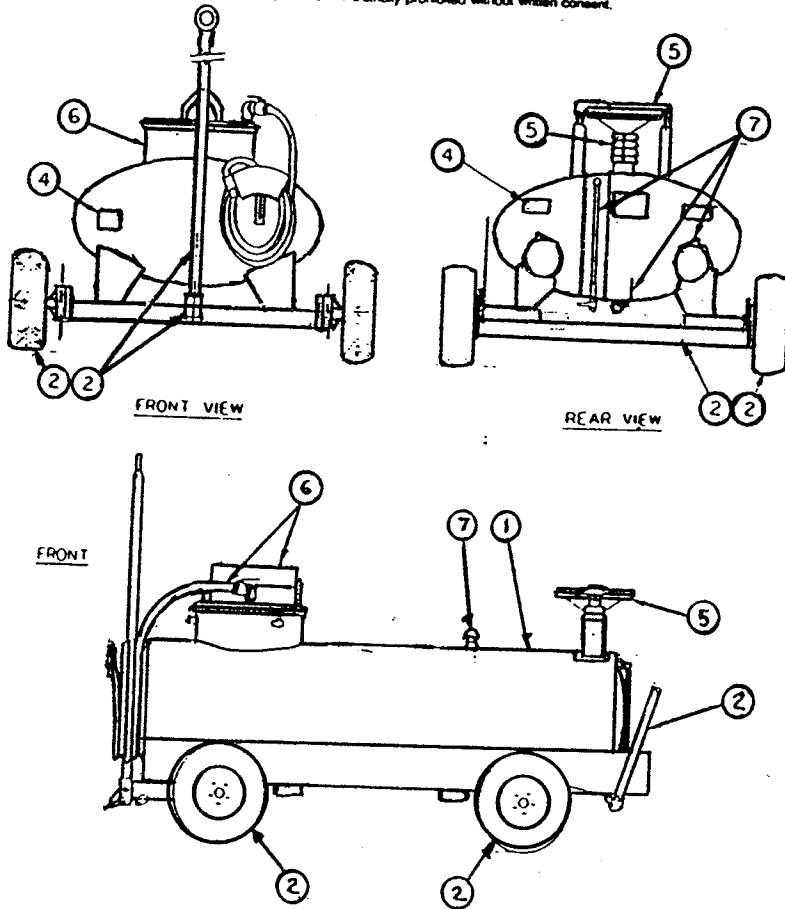

Item No.

Section

1	Main Tank	5.1
2	Axle, Front	5.2.1
2	Axle, Rear	5.2.2
2	Brake, Parking	5.2.3
2	Wheel Assembly, Front	5.2.4
2	Wheel Assembly, Rear	5.2.5
4	Decal Package	5.4
5	Telescoping Drain	5.5
6	Vacuum Assembly	5.6
7	Miscellaneous Fixtures	5.7
7	Vent, Overflow Preventor	5.8

SPOKANE METAL PRODUCTS

SPOKANE WASHINGTON
CONFIDENTIAL PROPRIETARY INFORMATION

Reproduction of this data or the manufacturing of products from this data by anyone other than Spokane Metal Products of Spokane WA is strictly prohibited without written consent.

5.1

1

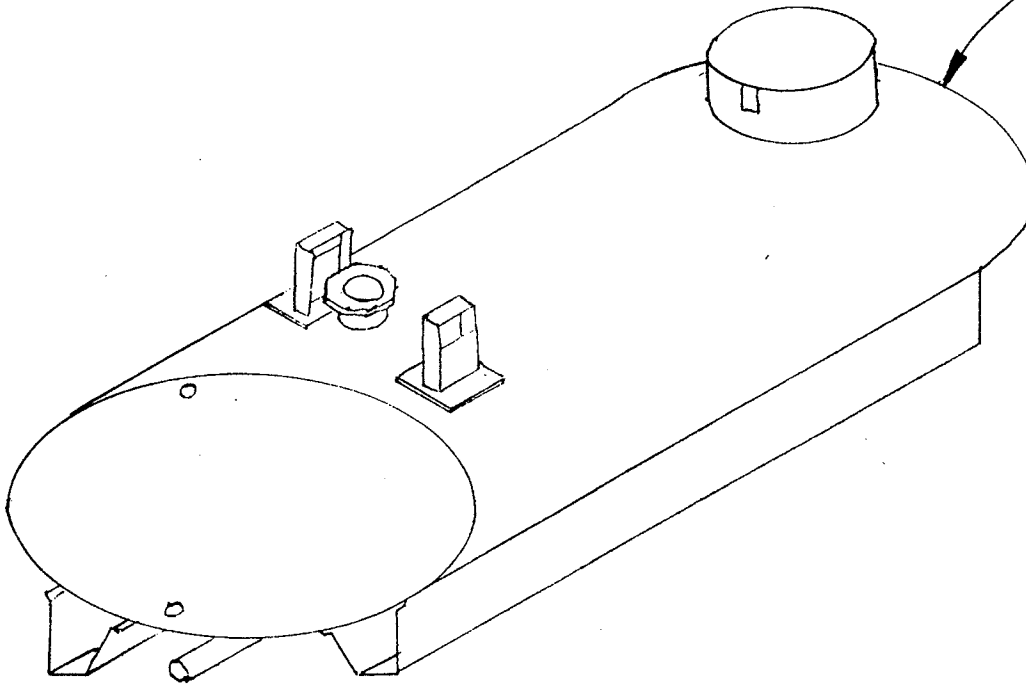

ASSEMBLY NO. S/O 8068

MAJOR ASSEMBLY - TANK WELDMENT

Sub Assy.	Item	Part No.	Quantity	Description	Wt. #
	1	W/O 11059	1	SPECIAL DOUBLE WALL Stainless Steel Tank Weldment, 200 Gallon Capacity Series BOW 200-07	375#

SECTION 5.2.1

PO Box 24821 Spokane, WA 99220 • P.O. Box 4, Spokane Industrial Park • (509) 325 0720 • TWX 35-0458

CONFIDENTIAL-PROPRIETARY INFORMATION
 REPRODUCTION OF THESE DRAWINGS OR THE MANUFACTURING OF PRODUCTS FROM THESE DRAWINGS FOR USE BY ANY-
 ONE OTHER THAN SPOKANE METAL PRODUCTS OF SPOKANE, WA IS STRICTLY PROHIBITED WITHOUT WRITTEN CONSENT

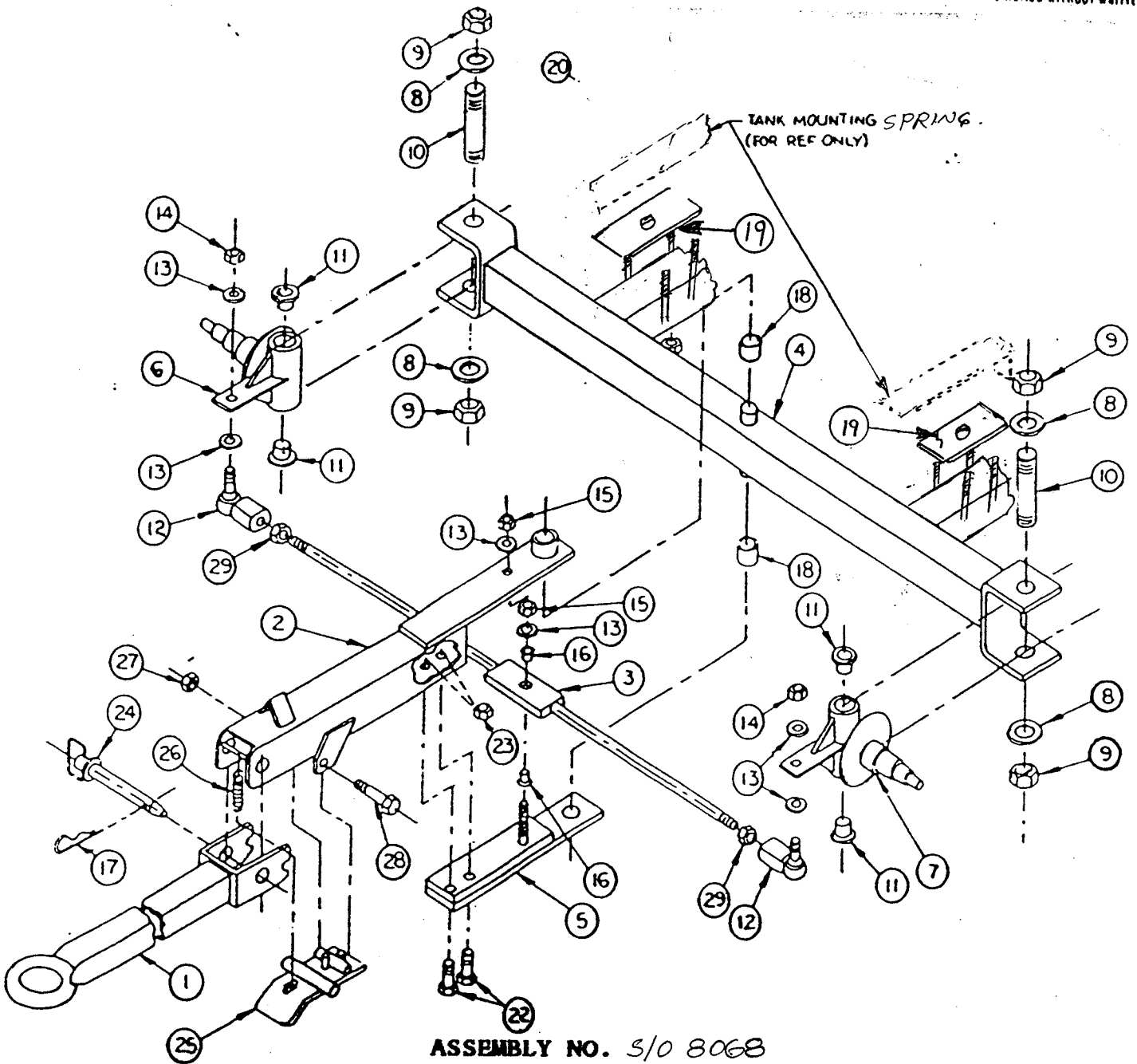

MAJOR ASSEMBLY - AXLE ASSEMBLY

Sub Assy.	Item	Part No.	Quantity	Description	Wt.#
S/O 8068				Axle, Assembly, Front	
	1	07-1103	1	Tow Bar	23
	2	07-1052	1	Arm, Turning	16
	3	w/o 11059	1	Tie Rod	7.3
	4	w/o 11059	1	Axle, Front	53

ASSEMBLY NO 5/0 8068

MAJOR ASSEMBLY - AXLE ASSEMBLY (CONTINUED)

Sub Assy.	Item	Part No.	Quantity	Description	Wt. #
	5	07-1046	1	Steering Arm, Lower Plate	6.1
	6	05-1009	1	Sleeve, King Pin, Right	24
	7	05-1009	1	Sleeve, King Pin, Left	24
	8	02-11131	4	Washer, King Pin	1
	9	02-12131	4	Nut, King Pin	2
	10	05-1010	2	King Pin	11
	11	03-1013	4	Bushing, King Pin Sleeve	1
	12	03-1016	2	Ends, Tie Rod	5
	13	02-11072	5	Washers, Tie Rod	
	14	02-12071	2	Nuts, Tie Rod Ends	1
	15	02-12071	1	Nut, Tie Rod Pivot	.5
	16	03-1015	2	Bushing, Tie Rod Pivot	.8
	17	02-1300	2	Cotter Pin	.2
	18	03-1014	2	Bushing, Axle Pivot	1
	19	W/O 11059	2	Mounting Pad, Tank	4
	20				
	21	W/O 11059	4	Nuts, Tank Mounting	.5
	22	02-1502	2	Bolts, Turning Arm Clamp	.32
	23	02-12041	2	Nuts, Turning Arm Clamp	.2
	24	02-1304	1	Hitch Pin	2
	25	07-1020	1	Toe Latch	3.1
	26	04-1054	1	Spring, Toe Latch	.5
	27	02-1201	1	Nut, Toe Latch	.1
	28	02-1501	1	Bolt, Toe Latch	.2
	29	02-12141	2	Hex Nut, Tie Rod	.2

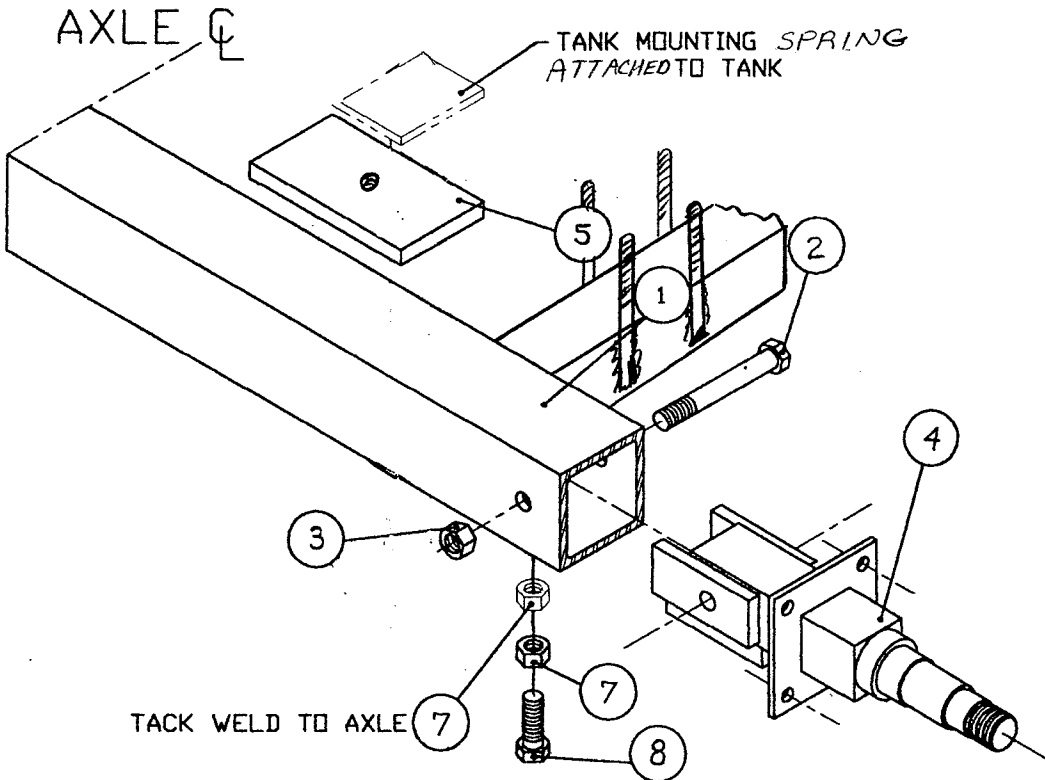

ASSEMBLY NO. *S/O 8068*

MAJOR ASSEMBLY - AXLE ASSEMBLY

Sub. Assy.	Item	Part No.	Qty.	Description	Wt.
<i>S/O 8068</i>				Axle Assembly, Rear	
	1	<i>W/O 11059</i>	1	Axle, Rear Weldment	40
	2	02-1505	2	Bolts, Mounting Spindle	.6
	3	02-12041	2	Nuts, Mounting Spindle	.5
	4	05-1022	2	Spindle, Rear	17
	5	<i>W/O 11059</i>	2	Mounting Pad, Tank	1
	6				
	7	<i>W/O 11059</i>	4	Nuts, Tank Mounting	.5
	8	02-10041	2	Bolt, Spindle Stabilizer	.5

CONFIDENTIAL PROPRIETARY INFORMATION
 Reproduction of this data or the manufacturing of products from
 this data by anyone other than Spokane Metal Products of
 Spokane, WA is strictly prohibited without written consent

SECTION 5.2.3.

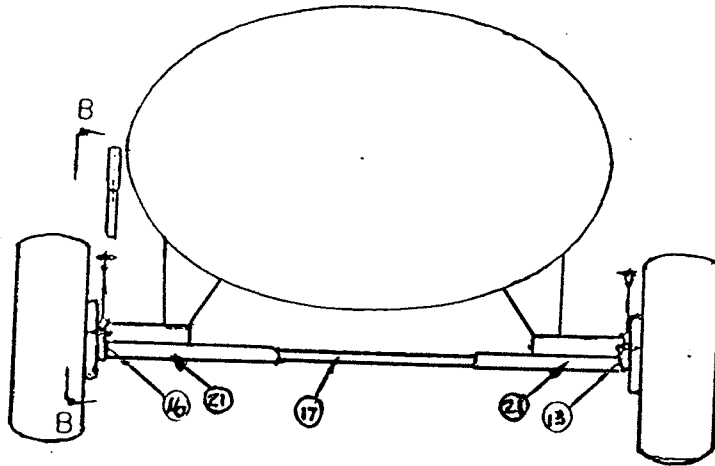
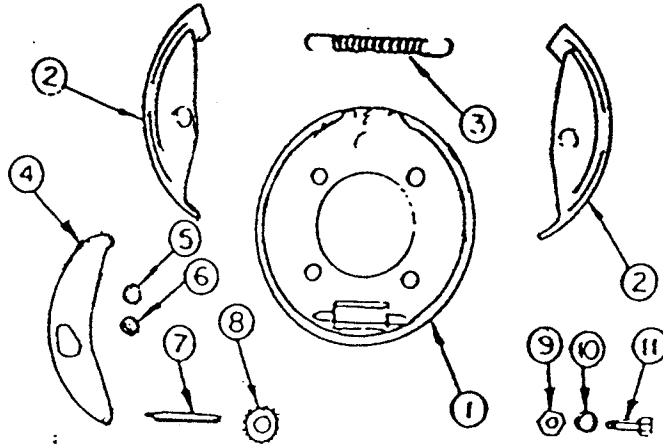

REAR VIEW

MTS

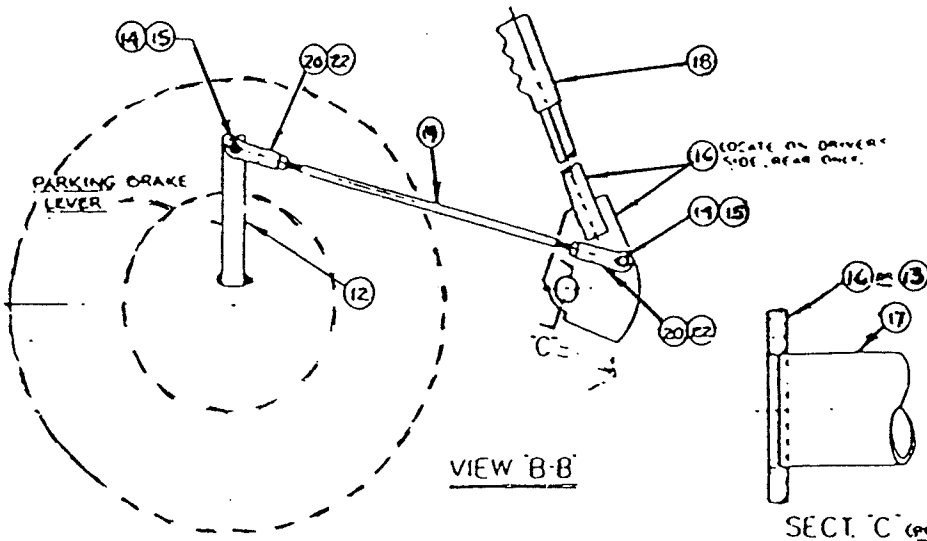

ASSEMBLY NO. 10-100030

MAJOR ASSEMBLY - BRAKE, PARKING

Sub Assy.	Item	Part No.	Quantity	Description	Wt.#
08-1007		04-1063		Brake Assembly (2 Req'd)	
	1	04-1023	1	Brake, Plate Assembly	7
	2	04-1024	1	Brake, Shoe Assembly	4
	3	04-1026	2	Brake, Shoe Lever Spring	1
	4	04-1025	2	Brake, Shoe Lever	1
	5	02-1400	2	1\2" Retaining Ring	.2
	6	02-1303	2	Anchor Pin	.2
	7/8	04-1027	2	Adjusting Screw Assembly	.7
	9	02-12031	4	Nut	.2
	10	02-11031	4	Lockwasher	.1
	11	02-10031	4	Bolt, 7/16" Shoulder	.5
	12	04-1030	1	Brake, Control Arm	3
08-1008				Brake Linkage Assembly	
	13	05-1025	1	Cam, Brake Linkage	1.4
	14	02-10012	1	Bolt	.4
	15	02-12021	1	Nut	.1
	16	07-1033	1	Brake Handle, Fabd Sub-Ass	5.4
	17	01-8104	1	Brake Handle, Connector	4
	18	04-1055	1	Grip, Vinyl	1
	19	05-1026	1	Rod, Brake Linkage	1
	20	04-2516	4	Yoke Ends	.5
	21	03-1020	2	Grease Fitting	.5
	22	02-100231	4	Jam Nut, 3/8"	.5

CONFIDENTIAL PROPRIETARY INFORMATION
Reproduction of this data or the manufacturing of products from
this data by anyone other than Spokane Metal Products of
Spokane, WA is strictly prohibited without written consent.

SECTION 5.2.4.

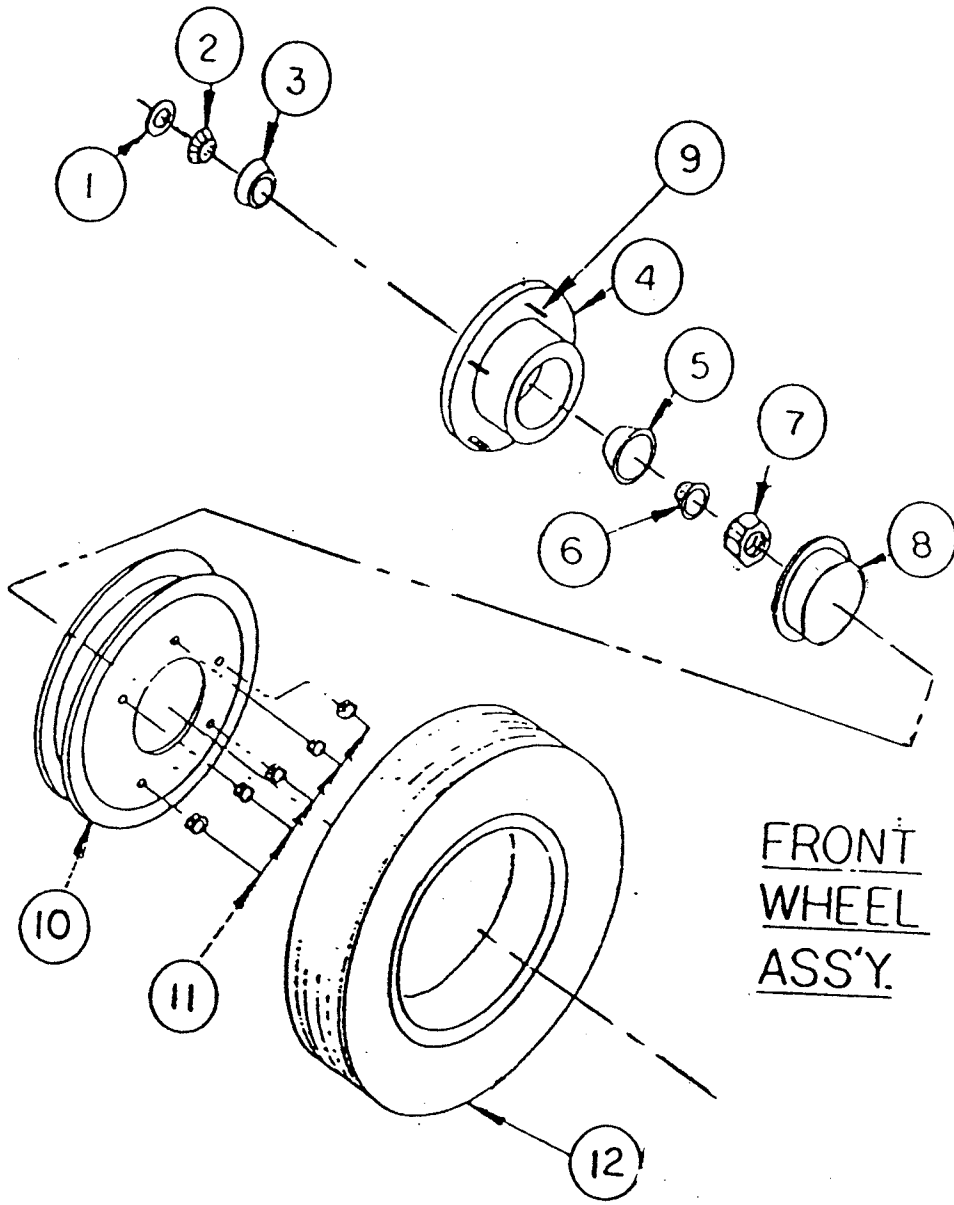

FRONT
WHEEL
ASS'Y.

ASSEMBLY NO. 10-100042

MAJOR ASSEMBLY - WHEEL ASSEMBLY, FRONT

Sub Assy.	Item	Part No.	Quantity	Description	Wt. ‡
08-1011		04-1050		Bearing & Hub Assembly (2 Reqd)	
	1	04-1012	1	Seal, Bearing	1
	2	04-1013	1	Bearing, Inner	3
	3	04-1015	1	Cup, Inner	2
	4	04-1017	1	Hub, Wheel	7
	5	04-1016	1	Cup, Outer	4
	6	04-1014	1	Bearing, Outer	3
	7	02-1205	1	Spindle Nut	1
	8	04-1019	1	Dust Cap	1
	9	02-1017	5	Studs, Hub	1
<i>S/O 8068</i>		<i>W/O 11059</i>		Tire/Wheel/Tube Assembly (2 Reqd)	
	10	<i>W/O 11059</i>	1	Wheel, 10"	9.5
	11	04-1021	5	Lug Nuts, Wheel	1
	12	04-10221	1	Tire, 10" "B"	4
	13				11

CONFIDENTIAL PROPRIETARY INFORMATION
Reproduction of this data or the manufacturing of products from
this data by anyone other than Spokane Metal Products of
Spokane WA is strictly prohibited without written consent

SECTION 5,2.5.

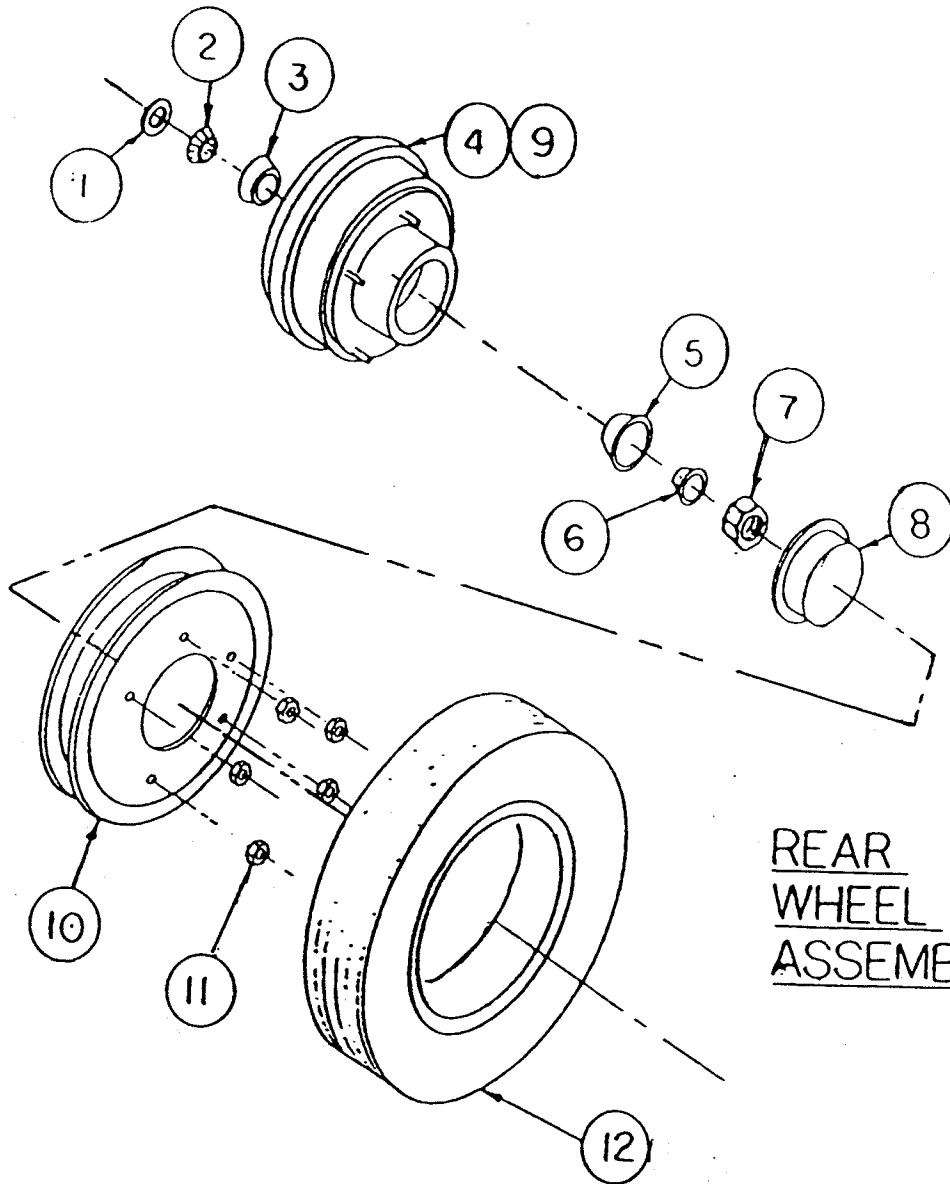

REAR
WHEEL
ASSEMBLY

ASSEMBLY NO. 10-100052

MAJOR ASSEMBLY - WHEEL ASSEMBLY, REAR

Sub Assy.	Item	Part No.	Quantity	Description	Wt. #
08-10111		04-1062		Bearing & Hub Assembly (2 Reqd)	
	1	04-1012	1	Seal, Bearing	1
	2	04-1013	1	Bearing, Inner	3
	3	04-1015	1	Cup, Inner	2
	4	05-1008	1	Hub/Brake Drum Sub-Assy	16
	5	04-1016	1	Cup, Outer	4
	6	04-1014	1	Bearing, Outer	3
	7	02-1205	1	Nut, Spindle	1
	8	04-1019	1	Dust Cap	1
<i>S/o 8068</i>		<i>w/o 11059</i>		Tire/Wheel/Tube Assembly (2 Reqd)	
	10	<i>w/o 11059</i>	1	Wheel,	9.5
	11	04-1021	5	Lug Nuts, Wheel	1
	12	04-10221	1	Tire, 10" "B"	4
	13				

CONFIDENTIAL PROPRIETARY INFORMATION

Reproduction of this document or the manufacture of products from this document for use by anyone other than SPOKANE METAL PRODUCTS, INC. of Spokane, Wa. is strictly prohibited without written consent.

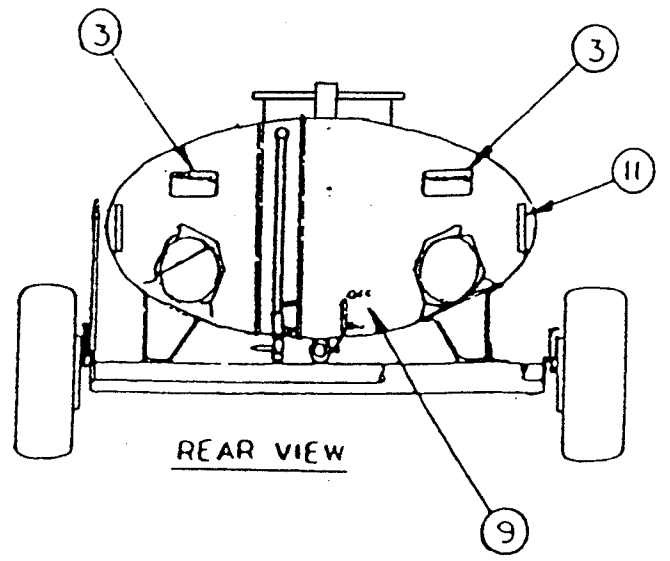
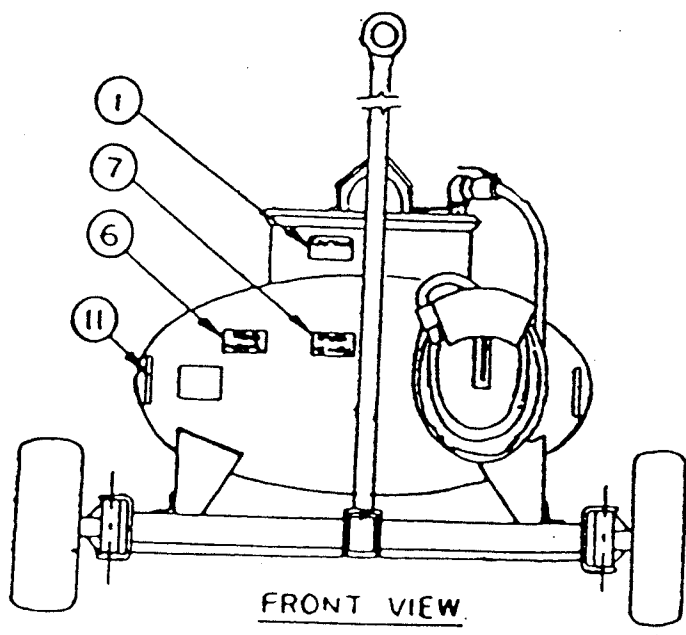
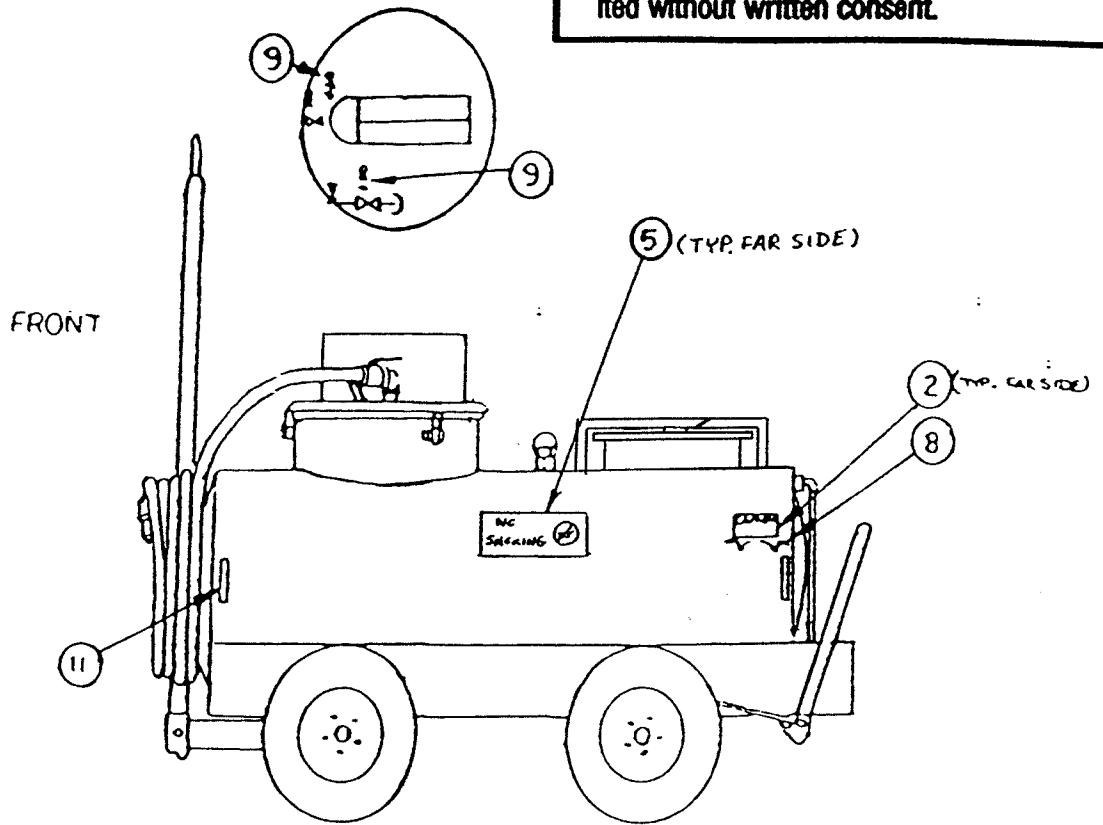

ASSEMBLY NO 10-100070

MAJOR ASSEMBLY - DECAL PACKAGE

Sub Assy.	Item	Part No.	Quantity	Description	Wt. #
10-100070				Decal Assembly	.1
	1	06-1002	1	Caution, Vacuum System	.1
	2	06-1003	1	Caution, Parking Brake	.1
	3	06-1004	2	Warning, Grounding Reels	.1
	4	06-1005	1	Warning, Telescoping Drain	.1
	5	06-1006	2	Danger, No Smoking	.2
	6	06-1007	1	Notice, Read Manual	.1
	7	06-1008	1	Maximum Towing Speed 15MPH	.1
	8	06-1010	1	Off/On, Parking Brake	.1
	9	06-1011	8	Off/On, Drain Valve	.8
	11		8	Reflector Tape	.8

SECTION 5.5

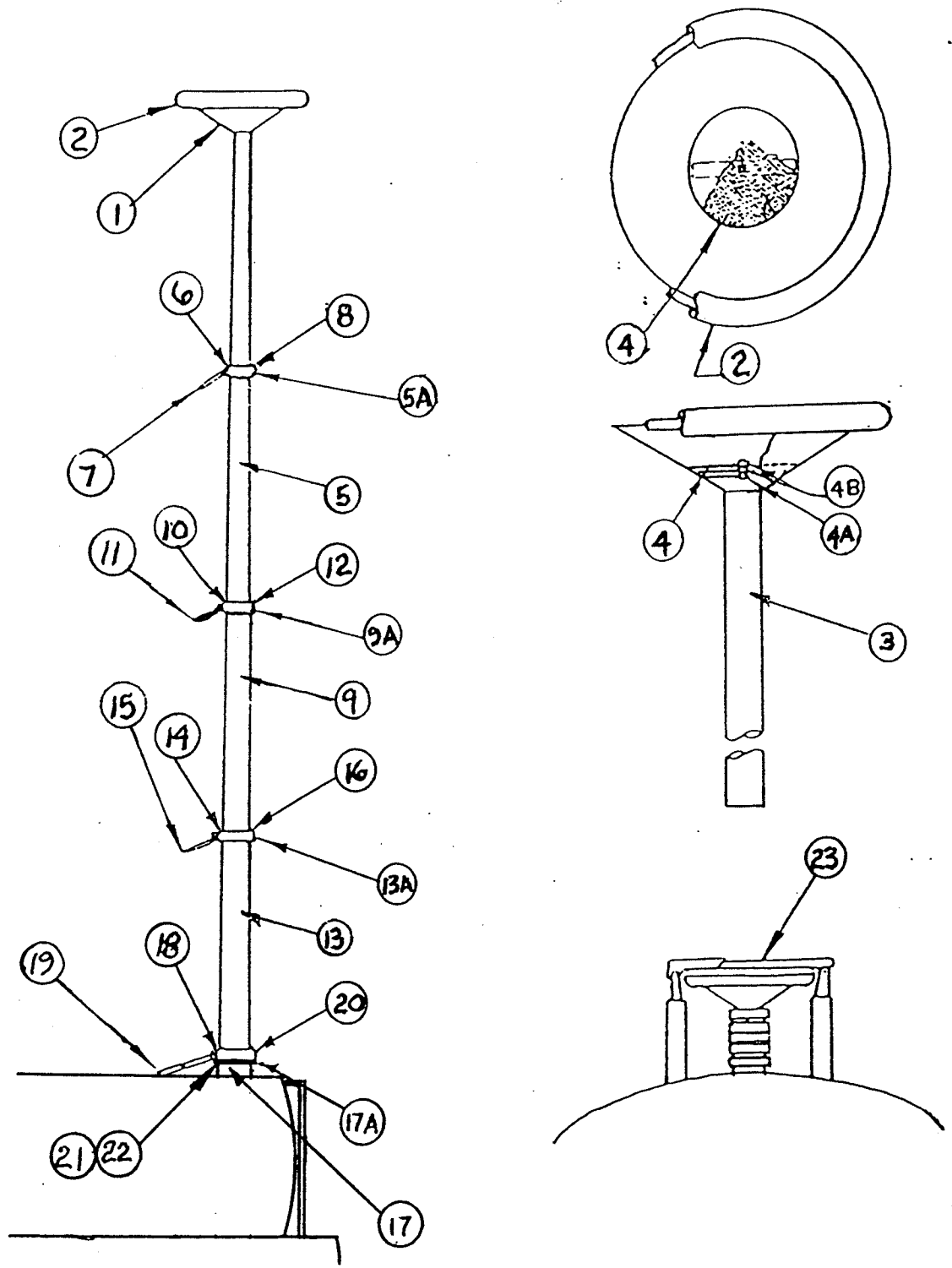

MAJOR ASSEMBLY - TELESCOPING DRAIN ASSEMBLY

Sub Assy.	Item	Part No.	Quantity	Description	Wt.#
07-1054W				Drain Funnel Section Assembly	
	1	01-8250	1	Drain, Top (funnel)	5
	2	06-1022	1	Gasket	.7
	3	01-92402	1	Tubing, 2" OD	
	4	04-1039	1	Screen	.5
	4A	2-10002	1	Bolt, 1/4"	.2
	4B	02-1200	1	Nut, 1/4"	.1
08-1012W				Drain, Telescoping Sect. Assembly, 2-1/2" OD	
	5A	05-10271	1	Clamp, 2"	
	5	01-9242	1	Tubing, 2-1/2" OD	
	6	05-10051	1	WEDGE, 1"x11/16"x1 1/4"	.2
	7	05-10181	1	HANDLE, CLAMP	.3
	8	02-1005	1	SCREW, SET	.01
08-1013W				Drain, Telescoping Sect. Assembly, 3" OD	
	9A	05-10281	1	Clamp, 2-1/2" OD	
	9	01-92452	1	Tubing, 3" OD	
	10	05-10021	1	WEDGE, 1"x7/8"x1 9/16"	.3
	11	05-10181	1	HANDLE, CLAMP	.3
	12	02-1005	1	SCREW, SET	.01

08-1014W				Drain, Telescoping Sect. Assembly, 3-1/2" OD	
	13A	05-10291	1	Clamp, 3" OD	
	13	01-9248	1	Tubing, 3-1/2" OD	
	14	05-10031	1	WEDGE, 1"x1 1/16"x1 13/16"	.4
	15	05-10181	1	HANDLE, CLAMP	.3
	16	02-1005	1	SCREW, SET	.01
07-1041				Drain, Telescoping Section Assembly, 3-1/2" O.D.	
	17A	05-10301	1	Clamp, 3-1/2" OD	
	17	01-9259	1	Tubing, 4" OD	
	18	05-10041	1	WEDGE, 1"x1 7/32"x2 1/8"	.5
	19	05-10181	1	Handles, Clamp	.3
	20	02-1005	1	SCREW, SET	.01
	22A	04-10562	1	Base Flange	
	25	02-100121	4	MOUNTING BOLTS, 1/4-16x3/4"	.2
	26	08-1026	1	COVER ASSEMBLY	5

SECTION 5.6

CONFIDENTIAL PROPRIETARY INFORMATION
Reproduction of this data or the manufacturing of products from this data by anyone other than
Spokane Metal Products of Spokane, WA is strictly prohibited without written consent.

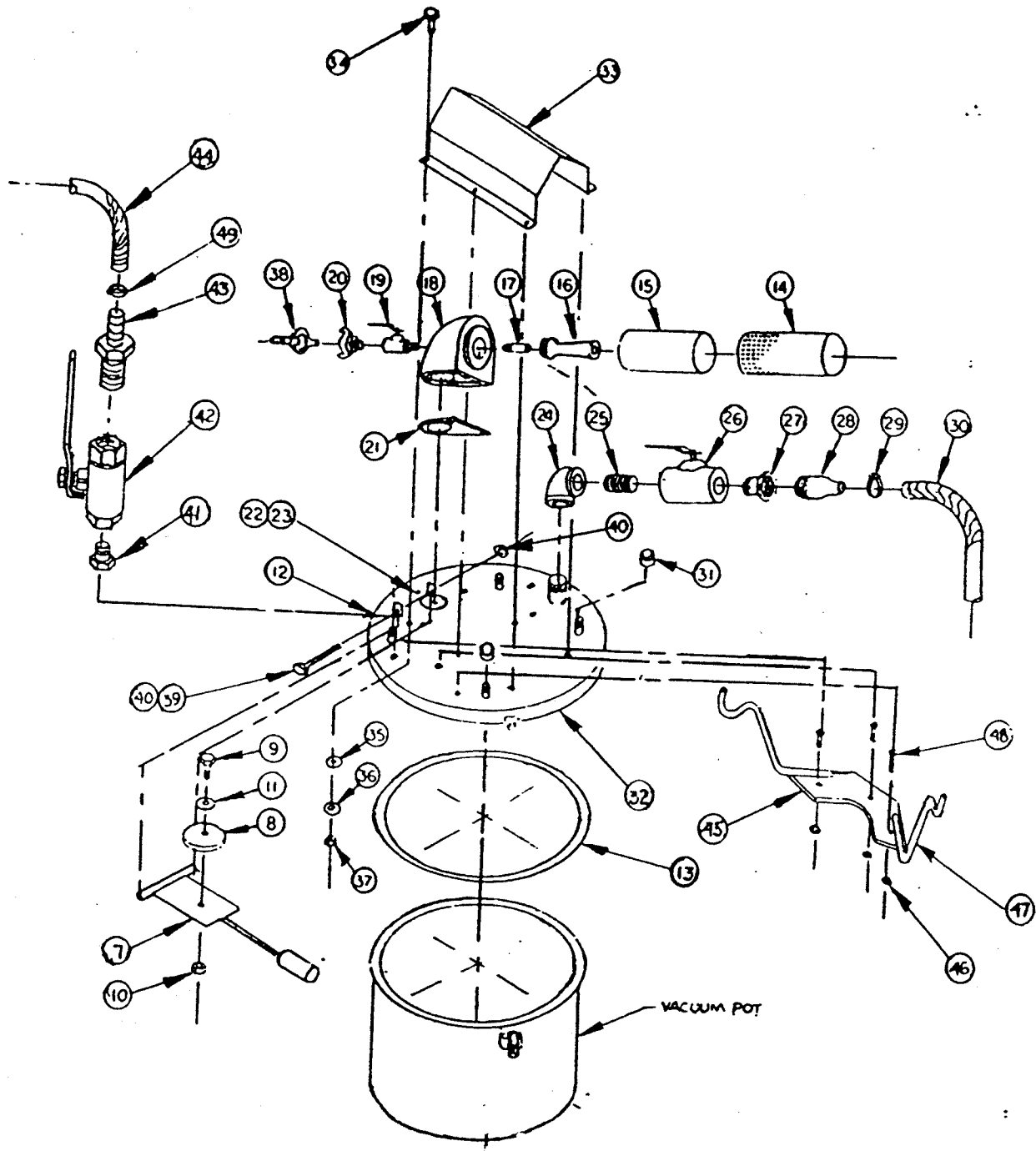

ASSEMBLY NO. 08-0001U

VACUUM SYSTEM ASSEMBLY

Sub Assy.	Item	Part No.	Quantity	Description	Wt. #
	1				3.5
	2				1.5
	3				.1
	4				.1
	5				.1
	6A				.1
	6B				.1
08-1001				Overflow Stop Assembly	
	7	07-1109	1	Float Sub. Assembly	4
	8	04-1001	1	Gasket	.1
	9	02-10003	1	Bolt	.1
	10	02-1200	1	Nut	.1
	11	02-1100	1	Flatwasher	.1
08-10022				Cover Assembly	
	12	07-1002	1	Lid	5
	13	06-1022	1	Gasket	2.7
08-1003				Nortech Vacuum Head Assy.	
	14	04-1004	1	Exhaust Housing	9.5
	15	04-1005	1	Exhaust Silencer	4.7
	16	04-1006	1	Venturi	2.2
	17	04-1007	1	Air Jet	2.7
	18	04-1008	1	Venturi Box	2.7
	19	04-1032	1	Valve	5.8
	20	04-1056	1	Coupler	1.7
	21	04-1010	1	Gasket	.1
	22	02-10010	3	Bolt	.1

ASSEMBLY NO. 08-0001U (CONTINUED)

VACUUM SYSTEM ASSEMBLY

	23	02-11001	3	Washer	.1
08-1004				Accessories	
	24	03-1001	1	Elbow	2
	25	03-02922S	1	Nipple	.5
	26	04-10321	1	Valve	3
	27	03-1002	1	Hex Bushing	.2
	28	03-1003	1	Nipple	.1
	29	03-10101	1	Hose Clamp	.1
	30	06-10161	1	Hose	15
	31	03-1021	4	Pipe Cap (Optional)	1
	32	07-1019	1	Lid	24
	33	07-1034	1	Cover, Vacuum Generator	8
	34	02-10010	6	Bolt	.1
	35	06-1021	6	Washer	.1
	36	02-1100	6	Washer	.1
	37	02-1200	6	Nuts	.1
	38	04-1057	1	Coupler	.5
	39	02-10016	1	Bolt	.5
	40	02-1201	1	Nut	.1
	41	03-10155	4	Bushing (Optional)	.5
	42	04-10320	4	Ball Valve (Optional)	4
	43	03-10091	4	Hose Barb (Optional)	2
	44	06-10185	4	Tubing (Optional)	4
	45	01-9026S	2	Hanger Plate (Optional)	3
	46	02-12014	6	Hex Nuts (Optional)	.5
	47	01-9172S	4	Tubing Hangers (Optional)	2.5
	48	02-100115	6	Bolt (Optional)	1
	49	03-101005	4	Hose Clamp (Optional)	.5

CONFIDENTIAL PROPRIETARY INFORMATION
Reproduction of this data or the manufacturing of products from
this data by anyone other than Sookane Metal Products of
Sookane WA is strictly prohibited without written consent

SECTION 5.7

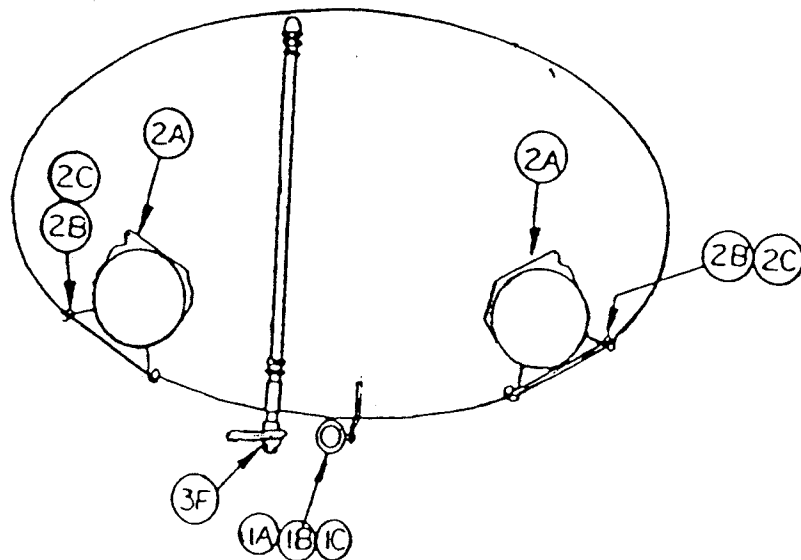
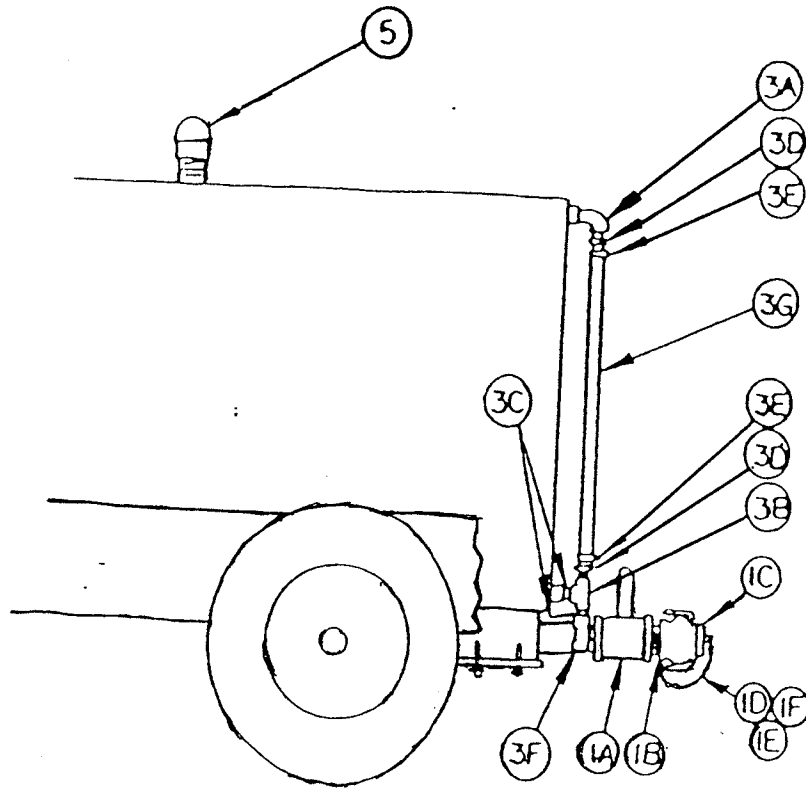

REAR VIEW

**STATIC DISCHARGE GROUNDING REEL
INSTALLATION / OPERATION INSTRUCTION SHEET
P/N 922-30-028**

Introduction

Static Discharge Reels; 200-20R, 700-50R and ML2930 & ML3416 Series to be used for bonding and grounding on mobile fuel equipment at bulk stations, airports, terminals, refineries, et cetera.

Bonding and Grounding Principles

Bonding connects various pieces of conductive equipment together to keep them at the same potential. Static sparking can not occur between objects that are at the same potential.

Grounding is a form of bonding in which conductive equipment is connected to an earthing electrode or to a building grounding system in order to prevent sparking between conductive equipment and grounding structures.

Refer to the National Fire Protection Association Codes, NFPA 77 and NFPA 99 for recommended practice on static electricity.

Reel Installation

Mount Grounding Reel to object or vehicle with bolts using holes provided in base. Underside of bracket is unpainted providing a conductive surface to interface with a clean conductive surface on the object or vehicle. After mounting reel check electrical continuity (25 ohms. max.) between object or vehicle and grounding clamps at the end of the cable.

Reel Operation

Extend cable to desired object or earthing ground lug and clamp alligator jaw grip or other grounding connector in place. A pawl and ratchet permits locking of cable at any desired length within the reel's capacity. A simple tug on the cable unlocks the reel for a smooth and steady walk-back retraction.

Perform periodic tests of the bonded object to the ground clamp on the end of the cable grounding reel with Ohm Meter to confirm continuity. Maximum resistance to be 25 ohms. If higher, remove and replace reel. Inspect the entire cable length for kinks and/or broken wires. Inspect the cable clamp for good compression force and/or damage.

Caution: Do not use any part of the electrical current carrying system as a ground for static grounding. Arcing and fires could occur from current feedback where static control grounds are tied into the electrical system neutral.

WARNING:

This product can aid in the discharge of static electricity. No prediction or advice, however, can be given about all the different conditions which can cause static discharges to accumulate. Moreover, it can not be guaranteed that the use of this product (without other precautionary steps) will prevent static ignited fires or explosions which may result in serious injury or death.

SEEK PROFESSIONAL ADVICE BEFORE INSTALLING AND / OR USING THIS PRODUCT.

ASSEMBLY NO. 10-100110

MAJOR ASSEMBLY - MISC. FIXTURES

Sub Assy.	Item	Part No.	Quantity	Description	Wt. #
08-1012				Drain Assembly	
	1A	04-10321	1	Ball Valve	6
	1B	04-1033	1	Camlock Adaptor	1.5
	1C	04-10331	1	Camlock Plug	.5
	1D	04-1034	1	Safety Chain	.2
	1E	04-1034	1	S-Hook, Safety Link	.1
	1F	04-1035	1	S-Hook, Safety Link	.1
08-1013				Grounding Reel Assembly	
	2	04-10361	1	Grounding Reel	12
	2A	04-1036	1	Grounding Reel	12
	2B	02-10040	4	Bolts	.3
	2C	02-12041	4	Nuts	.1
08-1014	3			Sight Gauge Assembly	
	3A	03-0017S	2	Elbow	.5
	3B	03-1007	1	Tee	.5
	3C	03-1008	2	Nipple	.5
	3D	03-11130	2	Hose Barb	1
	3E	03-1010	2	Hose Clamp	.1
	3F	04-1032	1	Ball Valve	2.7
	3G	06-2527	1	Tubing	.1
	5	04-1037	1	Vent	3

SECTION 5.8

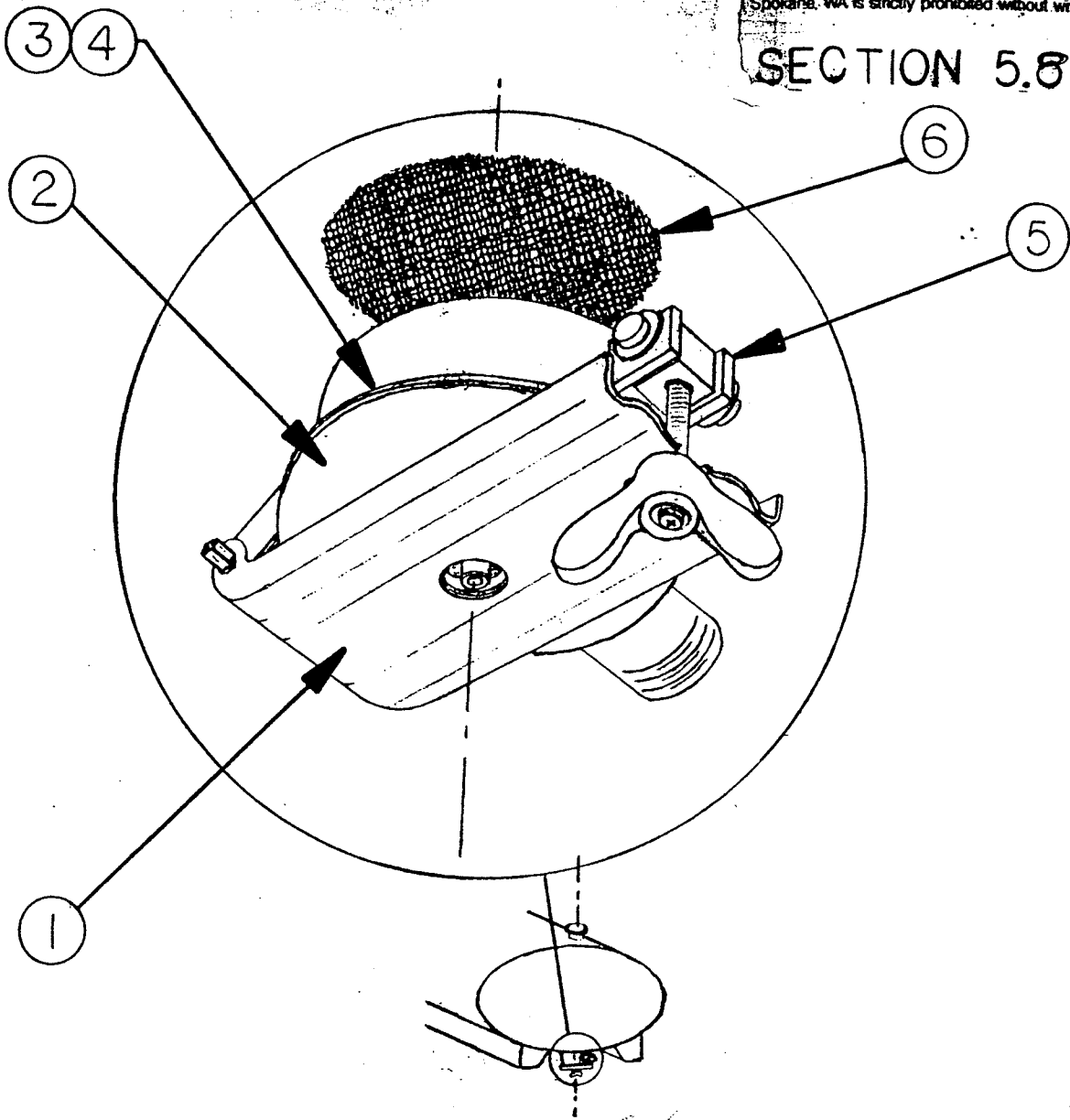

ASSEMBLY 07-1035

MAJOR ASSEMBLY - DRAIN SUMP ASSEMBLY

07-1035				DRAIN SUMP ASSEMBLY, 6"	12.4
	1	04-10581	1	REPAIR KIT INCLUDES ITEMS 2, 3, 4 & 5	6.3
	2	04-125252	1	COVER	2.3
	3	06-1058	1	GASKET, BLACK BUNA N	.4
	4	04-12637	1	GASKET RETAINER	1.4
	5	04-11162	1	PIVOTING WING NUT ASSY	2.1
	6	01-8223	1	SUMP STRAINER SCREEN	.1

CONFIDENTIAL PROPRIETARY INFORMATION
 Reproduction of this data or the manufacturing of products from
 this data by anyone other than Spokane Metal Products of
 Spokane WA is strictly prohibited without written consent

SECTION 5.9

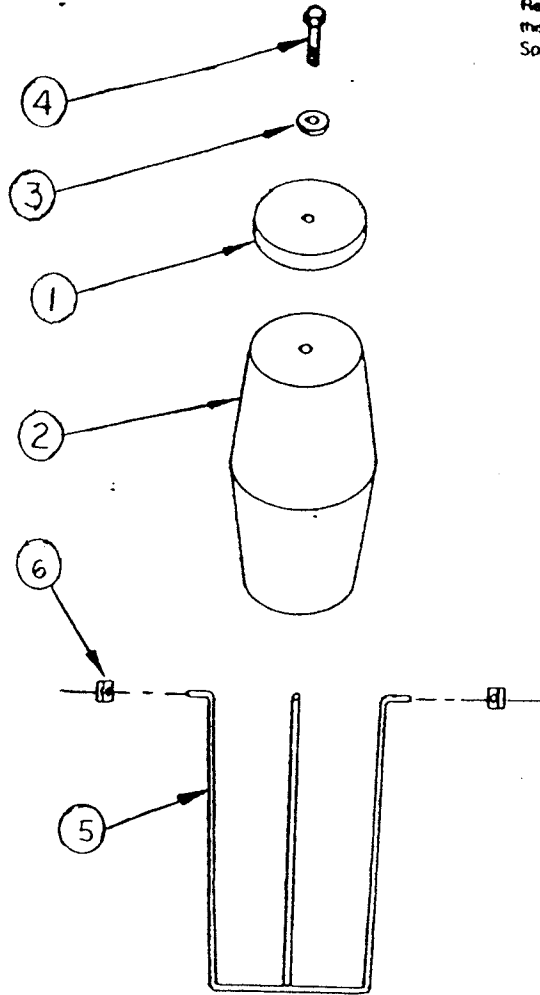

ASSEMBLY NO. 08-1001

MAJOR ASSEMBLY - VENT, OVERFLOW PREVENTOR

Sub Assy.	Item	Part No.	Quantity	Description	Wt. #
08-1022				Float Assembly	
	1	04-1047	1	Gasket	1
	2	06-1013	1	Float	.5
	3	02-1100	1	Washer	.1
	4	02-10001	1	Bolt	.1
08-1023				Cage Assembly	
	5	07-1032	2	Wire Cage	.9
	6	02-12140	4	Nut	.1

OPERATOR'S MANUAL

INCLUDING: OPERATION, INSTALLATION & MAINTENANCE

650709-C

650717-C

RELEASED: 10-5-89

REVISED: 9-25-93

(REV.C) IPP/PSE

1" DIAPHRAGM PUMP U.L. LISTED, 1:1 RATIO (METALLIC)

**IMPORTANT: READ THIS MANUAL CAREFULLY BEFORE INSTALLING,
OPERATING OR SERVICING THIS EQUIPMENT.**

THIS MANUAL COVERS THE FOLLOWING MODELS

MODEL	TH'D	DIAPHRAGM MATERIAL	APPLICATION
650709-C	NPT	BUNA "N"	Diesel Fuel, Kerosene, Aviation Fuel, Fuel Oil
666717-C	NPT	VITON	Unleaded Fuel

SERVICE KITS

637118-C for Air Section repair. (See page 6.)
637137-62 for repair of Model 650709-C Fluid Section.
637137-63 for repair of Model 650717-C Fluid Section.

PUMP DATA

MODELS - 650709-C, 650717-C
PUMP TYPE - U.L. Listed Metallic Air Operated Double Diaphragm
for use with Petroleum Product Dispensing Systems
MATERIAL - Aluminum Center Body, Fluid Caps and Manifolds
WEIGHT - 18.5 lbs
MAXIMUM AIR INLET PRESSURE - 50 p.s.i. (3.5 bar)
MAXIMUM OUTLET PRESSURE - 50 p.s.i. (3.5 bar)
MAXIMUM FLOW RATE (FLOODED INLET) 0-14 g.p.m.
MAXIMUM PARTICLE SIZE - 1/8" dia.
MAXIMUM TEMP. LIMITS - PVDF 10°F to 200°F (Seats)
DIMENSIONAL DATA - See page 8.

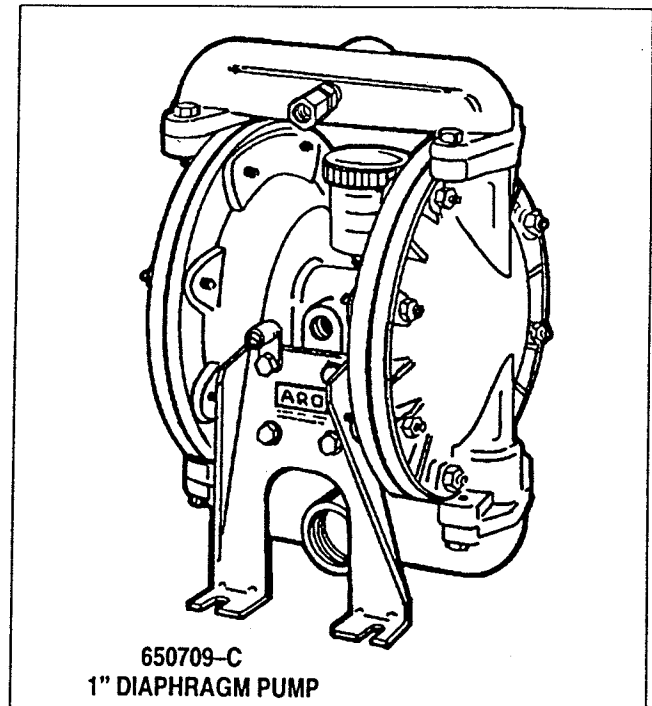

GENERAL DESCRIPTION

The ARO U.L. Listed pump for pumping petroleum products offers high volume delivery at low air pressures and easy self-priming. This model is designed specifically for the transfer, bulk un-loading or fueling

applications. It includes a pressure relief valve (per U.L. Specification 79) which restricts the fluid outlet pressure to under 50 PSI (3.5 bar). The relief valve can be plumbed to return the bleed off fuel to the storage container.

THE ARO CORPORATION • ONE ARO CENTER • BRYAN, OHIO 43506-0151
PH: (419) 636-4242 • FAX (419) 636-2115
©1993 THE ARO CORPORATION • PRINTED IN U.S.A.



Part of worldwide Ingersoll-Rand

OPERATING AND SAFETY PRECAUTIONS

- ▲ Read and heed all Warnings, Cautions, and Safety Precautions before operating this pump.
- ▲ Use only genuine ARO replacement parts to assure compatible pressure rating and longest service life.
- ▲ **WARNING: EXCESSIVE AIR PRESSURE.** CAN CAUSE PUMP AND PROPERTY DAMAGE. DO NOT EXCEED THE MAXIMUM INLET AIR PRESSURE AS STATED ON THE PUMP MODEL PLATE.
- ▲ **WARNING: STATIC SPARK.** FAILURE TO SAFEGUARD AGAINST STATIC SPARK, OPEN FLAME, HEAT AND IMPROPER VENTILATION COULD RESULT IN FIRE OR EXPLOSION CAUSING SEVERE PERSONAL INJURY AND/OR PROPERTY DAMAGE. THE PUMP MUST BE GROUNDED WHEN IT IS PUMPING, FLUSHING, OR RECIRCULATING INFLAMMABLE SUBSTANCES SUCH AS: PAINTS SOLVENTS, LACQUERS, ETC. OR USED IN A LOCATION WHERE SURROUNDING ATMOSPHERE IS CONDUCTIVE TO SPONTANEOUS COMBUSTION.
 - Use the pump grounding lug provided on metallic pumps for connection of a 12 ga. (min.) wire to a good earth ground source.
 - Ground dispensing valve or device, containers, hoses and any object to which material is being pumped.
 - After grounding, periodically verify continuity of electrical path to ground. Test with an ohmmeter from each component (e.g., hoses, pump, clamps, container, spray gun, etc.) to ground to insure continuity. Ohmmeter should show 10 ohms or less.
 - Secure pump, connections and all contact points to avoid vibration and generation of contact or static spark.
 - Consult local building codes and electrical codes for specific grounding requirements.
- ▲ **WARNING: DIAPHRAGM RUPTURE.** CAN CAUSE SERIOUS INJURY OR PROPERTY DAMAGE. MATERIAL CAN BE FORCED OUT OF THE AIR EXHAUST MUFFLER.
 - Pipe the exhaust to a safe remote location when pumping hazardous or inflammable materials.
 - Use a grounded 3/8" min. I.D. hose between the pump and the muffler.
- ▲ **WARNING: HAZARDOUS PRESSURE.** CAN RESULT IN SERIOUS INJURY OR PROPERTY DAMAGE. DO NOT SERVICE OR CLEAN PUMP, HOSES OR DISPENSING VALVE WHILE THE SYSTEM IS PRESSURIZED.
 - Disconnect air supply line and relieve pressure from the system by opening dispensing valve or device and/or carefully and slowly loosening and removing outlet hose or piping from pump.
- ▲ **WARNING: HAZARDOUS MATERIALS.** CAN CAUSE SERIOUS INJURY OR PROPERTY DAMAGE. DO NOT ATTEMPT TO RETURN A PUMP TO THE FACTORY OR SERVICE CENTER THAT CONTAINS HAZARDOUS MATERIAL. SAFE HANDLING PRACTICES MUST COMPLY WITH LOCAL AND NATIONAL LAWS AND SAFETY CODE REQUIREMENTS.
 - Obtain Material Safety Data Sheets on all materials from the supplier for proper handling instructions.

- ▲ **SAFETY PRECAUTIONS (GENERAL)** should include:

- Use of static wire hoses.
 - Submersion of outlet hose end, dispensing valve or device within material being dispensed whenever possible. (Avoid free streaming of material being dispensed.)
 - Proper ventilation of area away from heat, open flames and sparks.
 - Keeping inflammables away from heat, open flames and sparks.
 - Keeping containers closed when not in use.
 - Be sure material hoses and other components are able to withstand fluid pressures developed by this pump. Check all hoses for damage or wear. Be certain dispensing device is clean and in proper working condition.
- ▲ **CAUTION:** Verify the chemical compatibility of the pump wetted parts and the substance being pumped, flushed or recirculated. Chemical compatibility may change with temperature and concentration of the chemical(s) within the substances being pumped, flushed or circulated. Consult ARO Form No. 8677-P, Fluid Compatibility Guide, for information on chemical compatibility.
 - ▲ **CAUTION:** Maximum temperatures are based on mechanical stress only. Certain chemicals will significantly reduce maximum safe operating temperature. Consult Fluid Compatibility Guide for chemical compatibility and temperature limits.
 - ▲ **CAUTION:** Be certain all operators of this equipment have been trained for safe working practices, understand its limitations, and wear safety goggles/equipment when required.
 - ▲ **CAUTION:** Do not use the pump for the structural support of the piping system. Be certain the system components are properly supported to prevent stress on the pump parts.
 - Suction and discharge connections should be flexible connections (such as hose), not rigid piped, and should be compatible with the substance being pumped.
 - ▲ **CAUTION:** Prevent unnecessary damage to the pump. Do not allow pump to operate when out of material for long periods of time.
 - Disconnect air line from pump when system sits idle for long periods of time.

AIR AND LUBE REQUIREMENTS

▲ **WARNING: EXCESSIVE AIR PRESSURE CAN CAUSE PUMP AND PROPERTY DAMAGE. THE AIR SUPPLY MUST BE LIMITED TO 50 PSIG (3.5 BAR) MAXIMUM INLET AIR PRESSURE.**

- The air supply line or hose to the pump should be adequately sized to carry a sufficient volume of air to the pump. The material inlet supply tubing should not be too small or restrictive which will inhibit material flow. The outlet material volume is governed not only by the air supply but also by the material volume available at the inlet.
- Air supply provided should be filtered to provide clean dry air. A filter capable of filtering out particles larger than 50 microns should be used on the air supply. In most applications there is no lubrication required other than the "O"ring lubricant which is applied during assembly or repair.
- When lubricated air is necessary, supply the air lubricator with a good grade of SAE 90 wt. non-detergent oil and set the lubricator to a rate not to exceed one drop per minute.

INSTALLATION

IMPORTANT

- Requirements for the installation are included in the flammable and combustible liquids code, ANSI/NFPA No. 30 and the National Electric Code, ANSI/NFPA No. 70.
- A fluid return hose which is compatible with the fluid being pumped must be installed to the relief valve on the outlet manifold to return fluid back to the supply tank or pump inlet.
- The pump must be grounded to prevent static discharge. Grounding may be accomplished through the legs or to the ground lug provided on the pump.
- Notice that the material inlet/outlet manifolds may be removed and rotated 180° to facilitate various mounting applications.
- If the body of the pump must be rotated remove the end covers and manifolds and index it so the bolts line up properly. NOTE: The arrow on the end caps must always point upward for optimum performance.
- When the Diaphragm Pump is used in a force-feed situation it is recommended that a Check Valve be installed at the air inlet to keep material out of air line in the event of diaphragm failure.
- Secure diaphragm pump legs to a suitable surface to insure against damage by excessive vibration.

OPERATING INSTRUCTIONS

- The pump should never be operated at pressures exceeding 50 PSIG inlet air pressure. This pump is equipped with a pressure relief valve on the material outlet manifold which will open at 45+/-4 PSI to relieve pressure increases in the outlet hoses/plumbing caused by thermal expansion or other external forces.
- Disconnect the air supply from the pump if it is to be inactive for a few hours.

MAINTENANCE

Refer to the part views and descriptions as provided on page 4 through 7 for parts identification and Service Kit information.

- Certain ARO "Smart Parts" are indicated which should be available for fast repair and reduction of down time.
- Service kits are divided to service two separate diaphragm pump functions: 1. AIR SECTION, 2. FLUID SECTION. The FLUID SECTION is divided further to match typical part MATERIAL OPTIONS.
- Provide a clean work surface to protect sensitive internal moving parts from contamination from dirt and foreign matter during service disassembly and reassembly.
- Keep good records of service activity and include pump in preventive maintenance program.
- Before disassembling empty captured material in the outlet manifold by turning the pump upside down to drain material from the pump.

PARTS LIST / FLUID SECTION

FLUID SECTION SERVICE KITS

✓ KITS INCLUDE: (22) BALLS, (7) DIAPHRAGM, Items: 2, 3, 9, 19, (Refer to chart below) and 93706-1 Key-Lube grease.

MATERIAL CODE

[A]=Aluminum
 [B]=Buna "N"
 [BR]=Brass
 [C]=Carbon Steel
 [D]=Acetal
 [K]=P.V.D.F. (Kynar)
 [N]=Neoprene
 [S]=Steel
 [SS]=Stainless Steel
 [T]=Teflon
 [V]=Viton

WETTED COMMON PARTS

ITEM	DESCRIPTION (SIZE IN INCHES)	QTY	650709-C (BUNA)		650717-C (VITON)	
			PART NO.	[MT]	PART NO.	[MT]
	Fluid Section Service Kits		637137-62		637137-63	
□1	Rod	★(1)	98724-1	[C]	98724-1	[C]
✓2	"O"Ring (3/4 O.D.)	(1)	Y330-113	[B]	Y330-113	[B]
✓3	"O"Ring (5/8 O.D.)	(4)	92957	[B]	Y327-014	[V]
5	Plate (Air side) (3-3/8 O.D.)	(2)	93441-2	[S]	93441-2	[S]
□6	Plate (Fluid side) (3-3/8 O.D.)	(2)	93441-2	[S]	93441-2	[S]
✓7	Diaphragm	(2)	90533-2	[B]	90533-3	[V]
✓9	Washer (5/8)	(2)	93189-1	[SS]	93189-1	[SS]
14	Screw	(2)	Y5-85-K	[S]	Y5-85-K	[S]
15	Fluid Cap	(2)	92002	[A]	92002	[A]
16	Manifold (Top w/valve port)	(1)	93127	[A]	93127	[A]
	Manifold	(1)	92001	[A]	92001	[A]
✓19	"O"Ring (1-9/16 O.D.)	(4)	92961	[B]	Y327-126	[V]
21	Seat	(4)	92941	[K]	92941	[K]
✓22	Ball	(4)	90532-6	[D]	90532-6	[D]
26	Bolt (5/16-18 x 1)	(8)	Y6-55-C	[S]	Y6-55-C	[S]
29	Nut (5/16-18)	(16)	Y12-5-C	[S]	Y12-5-C	[S]
43	Ground Lug	(1)	93004	[S]	93004	[S]
	Pressure Relief Valve (See Pg. 8)	(1)	93130	[BR]	93130	[BR]

Service Note: Part No. 98930-T Installation Tool is available separately for use with items (1) and (2).

★Service Kit Note: Extra O-rings are included in kits to service models built prior to Sept. 1989.

FLUID SECTION DISASSEMBLY

1. Remove top manifold(s).
2. Remove (22) balls, (19) "O"rings, (21) seats.
3. Remove (15) fluid caps.
4. Remove the (14) screw, (9) washer, (3) "O"ring, (6) plate, (7) diaphragms, and (5) plates.
5. Remove (3) "O"Rings.

NOTE: Do not scratch or mar the surface of (1) diaphragm rod.

FLUID SECTION REASSEMBLY

- Reassemble in reverse order.
- Clean and inspect all parts. Replace worn or damaged parts with new parts as required.
- Lubricate diaphragm rod (1) and (2) "O"ring with Key-Lube® "O"ring lube or equivalent.
- Use ARO PN/98930-T Bullet (installation tool) to aid in installation of "O"ring (2) on diaphragm rod (1).
- Be certain (7) diaphragms align properly with (15) fluid caps before making final torque adjustments on bolt and nuts to avoid twisting the diaphragm.
- Re-check torque settings after pump has been re-started and run a while.

□ "Smart Parts" keep these items on hand in addition to the Service Kits for fast repair and reduction of down time.

TROUBLE SHOOTING

Product discharged from exhaust outlet.

- Check for diaphragm rupture.
- Check tightness of diaphragm nut.

Air bubbles in product discharge.

- Check connections of suction plumbing.
- Check "O"rings between intake manifold and fluid caps.
- Check tightness of diaphragm nut.

Low output volume, erratic flow, or no flow.

- Check air supply.
- Check for plugged outlet hose.
- Check for kinked (restrictive) outlet material hose.
- Check for kinked (restrictive) or collapsed inlet material hose.
- Check for pump cavitation – suction pipe should be sized at least as large as the inlet thread diameter of the pump for proper flow if high viscosity fluids are being pumped. Suction hose must be a non-collapsing type, capable of pulling a high vacuum.
- Check all joints on the inlet manifolds and suction connections. These must be air tight.
- Inspect the pump for solid objects logged in the diaphragm chamber or the seat area.

DIMENSIONAL DATA

(Dimensions shown are for reference only, they are displayed in inches and millimeters (mm).)

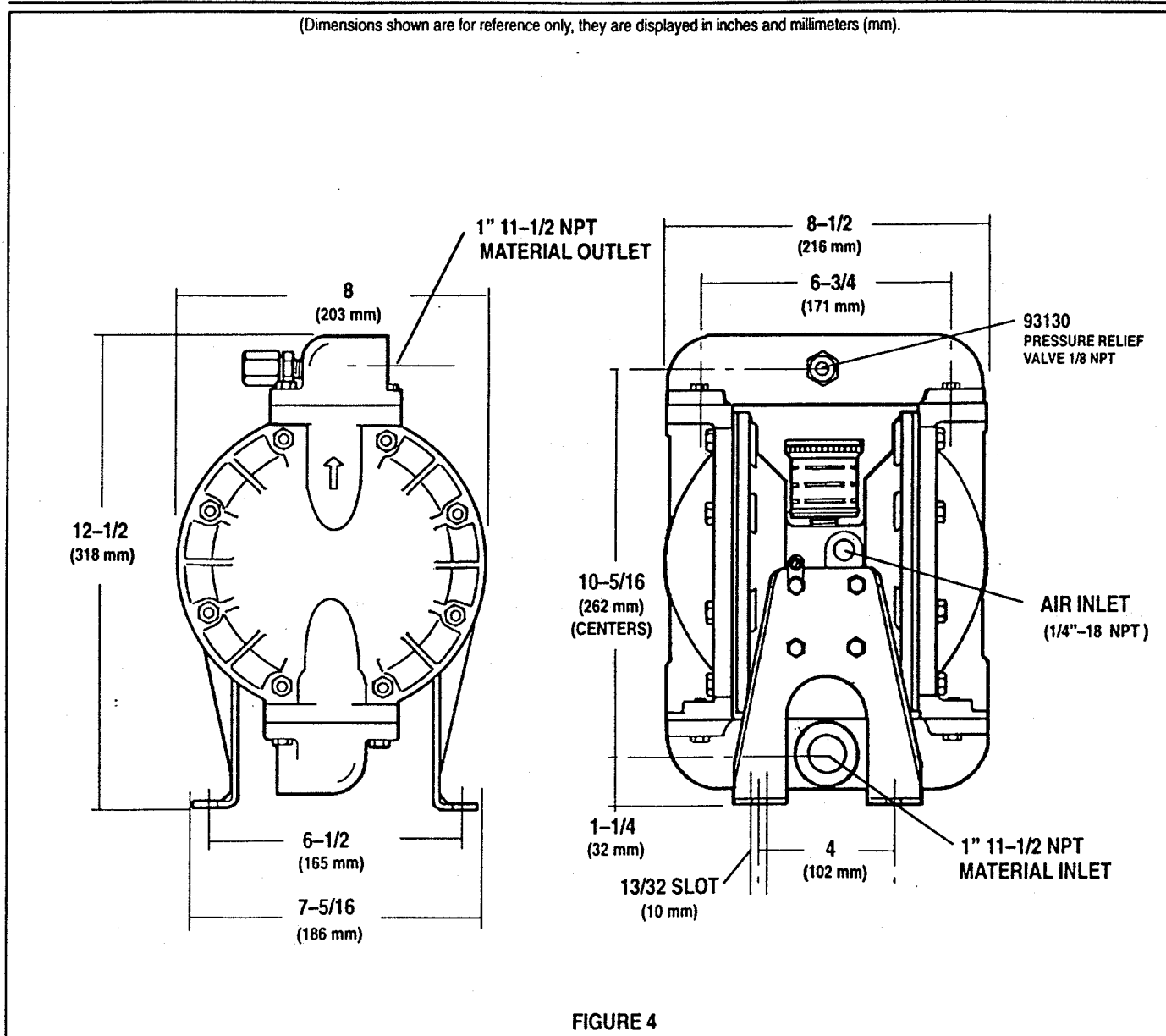



MOTOR WHEEL & PARTS, Inc.

YOUR UNDERCARRIAGE SPECIALISTS

Seattle

Portland

Spokane

DBA Bearing & Rim

TRAILER SPRINGS

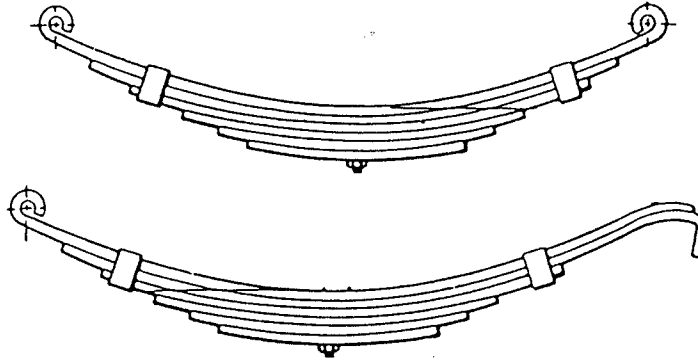

DOUBLE EYE SPRINGS

PART NO.	CAPACITY EA.	DESCRIPTION	NO. LEAVES
AS-3	450 lb	1.75"x26" Eye to Eye	3
AS-4	600 lb	1.75"x26" Eye to Eye	4
AWS-2	750 lb	1.75"x26" Eye to Eye	2
AWS-3	1125 lb	1.75"x26" Eye to Eye	3
AWS-4	1500 lb	1.75"x26" Eye to Eye	4
ATS-5	1250 lb	1.75"x26" Eye to Eye	5
AWS-5	1875 lb	1.75"x26" Eye to Eye	5
AWS-6	2250 lb	1.75"x26" Eye to Eye	6
AWS-7	2600 lb	1.75"x26" Eye to Eye	7
MR-4	3000 lb	1.75"x26" Eye to Eye	4
72-6	1250 lb	1.75"x23" Eye to Eye	3
72-9	1750 lb	1.75"x23" Eye to Eye	3
72-16	700 lb	1.75"x20.5" Eye to Eye	3
72-17	1000 lb	1.75"x20.5" Eye to Eye	3
72-18	2000 lb	1.75"x23" Eye to Eye	4
72-20	2500 lb	1.75"x23" Eye to Eye	4
72-23	1500 lb	1.75"x25.25" Eye to Eye	3
72-24	2000 lb	1.75"x25.5" Eye to Eye	3
72-25	2500 lb	1.75"x25.5" Eye to Eye	4
72-26	3000 lb	1.75"x25" Eye to Eye	4
72-27	3500 lb.	1.75"x25" Eye to Eye	6

HANGER KIT HK1
P013648

SLIPPER SPRINGS

PART NO.	CAPACITY EA.	DESCRIPTION	NO. LEAVES
72-2	1000 lb	* 1.75"x27.5" Slipper	* 2
72-3	700 lb	1.75"x28" Slipper	2
72-5	6000 lb	3"x30.5" Slipper	6
72-8	7500 lb	3"x30.25" Slipper	7
72-10	4500 lb	2"x30.5" Slipper	6
72-21	5000 lb	2.5"x30.75" Slipper	5
72-29	1500 lb	2"x26.75" Slipper	4
72-30	2000 lb	2"x26.75" Slipper	4
72-31	2500 lb	2"x26.75" Slipper	4
72-32	3500 lb	2"x26.75" Slipper	5

SPOKANE METAL PRODUCTS

A DIVISION OF SPOKANE INDUSTRIES, INC.

TELEPHONE 509/928-0750
 BUILDING NO. 4, SPOKANE INDUSTRIAL PARK
 P.O. BOX 3303, SPOKANE, WASHINGTON 99220 U.S.A.

TO 608⁵ SIX ROBBLEES

PURCHASE ORDER NO 013648

SHOW THIS NUMBER ON ALL PAPERS AND PACKAGES

Date <u>8-24-94</u>	Ordered By <u>K.C.</u>
Required	Terms <u>N-30</u>
F.O.B. <input type="checkbox"/> Our Plant <input type="checkbox"/> Shipping Point <input type="checkbox"/> Other	
Freight <input type="checkbox"/> Prepay & Invoice <input type="checkbox"/> Prepay & Allow <input type="checkbox"/> Collect	
Ship To	
Ship Via	
Routing/Special Instructions	

PHONE	CONTACT <u>BOB</u>
-------	--------------------

B/O	QTY.	PART NO.	✓	DESCRIPTION	DO NOT CHARGE SALES TAX ON ITEMS CHECKED	DISTR.	WORK ORD. COLUMN	UNIT COST	COST EXTENSION
	<u>16</u>			<u>HK 1 - HANGER KITS 1-PR SPRINGS</u>			<u>2-11060 6-11059 8-11058</u>	<u>9.60</u>	
	<u>16</u>			<u>72-16 - 750# SPRINGS</u>			<u>4-11060 12-11059</u>	<u>9.11 EA.</u>	
	<u>16</u>			<u>72-9 1750# SPRINGS</u>			<u>16-11058</u>	<u>16.25 EA.</u>	
	<u>36</u>			<u>"B" RANGE TIRES MOUNTED ON TUBELESS RIMS</u>			<u>4-11060 12-11059</u>	<u>44.20 EA.</u>	
	<u>16</u>			<u>"E" RANGE TIRES MOUNTED ON TUBELESS RIMS.</u>			<u>16-11058</u>	<u>63.24 EA.</u>	

Requisitioned By	Req. No.	Approved By	Dept.	Charge Account <u>139</u>
------------------	----------	-------------	-------	---------------------------

RENDER INVOICES IN DUPLICATE

BY ACCEPTANCE OF THIS ORDER, THE VENDOR AGREES TO COMPLY WITH THE PRICES, TERMS, DELIVERY, SPECIFICATIONS AND INSTRUCTIONS STATED HEREON, AND AGREES TO REIMBURSE SPOKANE INDUSTRIES, INC. FOR ANY LOSS OR DAMAGE RESULTING FROM VENDOR'S FAILURE TO COMPLY IN EVERY DETAIL.

SPOKANE INDUSTRIES, INC.

BY [Signature]
 Authorized Signature
 PURCHASING DIRECTOR

CAUTION:
NEVER ATTEMPT TO OPERATE THIS UNIT WITHOUT
FIRST OPENING THE VENT VALVE.

NOTICE:
NEVER OPERATE THE VACUUM, PRESSURING DRAIN TUBE OR
COLLAR AND THE CONDENSATES TUBE.

NOTICE:
NEVER OPERATE THE VACUUM, VENT VALVE TUBE OR CLOSED
KNEE VENT VALVE OR OTHERWISE.