

SPOKANE INDUSTRIES, INC.

SPOKANE METAL PRODUCTS DIVISION

Spokane Washington

CONFIDENTIAL PROPRIETARY INFORMATION

Reproductions of this data or the manufacturing of products from
This data by anyone other than Spokane Industries, inc. of Spokane
Washington is strictly prohibited without written consent.

400 GALLON

VACUUM FUEL BOWSER

TECHNICAL MANUAL

PARTS, OPERATION AND MAINTENANCE

MODEL NUMBER BOW 400-0216-FV

**© COPYRIGHT 2004 By SPOKANE INDUSTRIES INC.
ALL RIGHTS RESERVED**

This document discloses subject matter in which Spokane Industries, Inc has Proprietary rights and such subject matter shall not, without the written permission of Spokane Industries, Inc., be either (A) used, released or disclosed in whole or in part outside the government, (B) used in whole or in part by the government, for manufacture, or (C) used by a party other than the government, except for (1) emergency repair or overhaul work only, by or for the government, where the item or process concerned is not otherwise reasonably available to enable timely performance of the work, provided that release of disclosure hereof outside the government shall be made subject to a prohibition against further use, release of disclosure, or (2) release to a foreign government, or for emergency repair or overhaul work by or for such government under the conditions of (1) above. This legend shall be marked on any reproduction hereof in whole or in part.

Spokane Industries, Inc.
Spokane Metal Products Division
P.O. Box 3303
Spokane, WA 99220-3303
Telephone: (509) 928-0720
Tele Fax: (509) 927-0826
[Http://www.SpokaneIndustries.com](http://www.SpokaneIndustries.com)

400 GALLON VACUUM FUEL BOWSER
TECHNICAL MANUAL
PARTS, OPERATION AND MAINTENANCE
MODEL NUMBER BOW 400-0216-FV

INDEX

		<u>PAGE</u>
<u>Section 1.</u>	Introduction	1
<u>Section 2</u>	Safety	1
<u>Section 3</u>	Operation	
	3.1 Intended Use	3
	3.2 Tow Bar and Under Carriage	3
	3.3 Parking Brake	3
	3.4 Manway	3
	3.5 Reserved for future use	3
	3.6 Sample Port	3
	3.7 Grounding	4
	3.8 Drain Valve	4
	3.9 Telescoping Drain Assembly	4
	3.10 Telescoping Drain Sump Assembly	5
	3.11 Vacuum Assembly	5
	3.12 Vacuum Governor	5
<u>Section 4</u>	Maintenance	
	4.1 Tow Bar and Under Carriage	5
	4.2 Parking Brake	6
	4.3 Manway	6
	4.4 Reserved for future use	6
	4.5 Reserved for future use	6
	4.6 Grounding	6
	4.7 Telescoping Drain Assembly	7
	4.8 Telescoping Drain Sump	7
	4.9 Vacuum Assembly	7
	4.10 Vacuum Governor	8
	4.11 Reserved for future use	8
	4.12 Trouble Shooting	8

INDEX

<u>Section 5</u>	Replacement Parts	9
	Assembly Tank	10
5.1	Main Tank	11
5.2.1	Front Axle Assembly	12
5.2.2	Front Wheel Assembly	14
5.2.4	Rear Axle Assembly	16
5.2.2	Rear Wheel Assembly	17
5.2.3	Parking Brake Assembly	19
5.3	Manway Assembly	21
5.4	Decal Package	22
5.5	Telescoping Drain Assembly	24
5.5.1	Telescoping Drain Sump Assembly	27
5.6	Vacuum Assembly	28
5.6.1	Vacuum Governor Assembly	31
5.7	Miscellaneous Fixtures	32
5.8	Remote Drain Funnel Assembly	34
<hr/>		
<u>Warranty</u>	37

1.0

Introduction

- 1.1 To obtain optimum benefit from your vacuum fuel bowser unit, it is recommended that all personnel operating it read and understand this manual prior to operation.
- 1.2 Upon receipt of the bower unit, a visual inspection should be made to determine that it is complete and has not sustained any damage during transportation.

2.0

Safety

2.1 Potential Fire and Explosion

- 2.1.1 Due to the nature of fuel, care should be exercised to eliminate all sparks and open flame in the area of the bowser unit.
- 2.1.2 A 50-foot radius area around the bowser unit for no smoking, sparks or open flames is usually a good practice. It is strongly recommended all local or other regulations be consulted for further restrictions.

CAUTION: The vacuum fuel bowser should never be used inside of an enclosed area. Proper ventilation is required at all times.

2.2 Telescoping Drain

- 2.2.1 Care should be exercised in using the telescoping assembly to prevent injuring fingers between clamps by dropping sections.

2.3 Grounding

- 2.3.1 To eliminate static sparks; the vacuum fuel bowser unit is equipped with two (2)-grounding reels. Connect prior to draining or filling operations as described in the "Operations Section".

2.4 Towing

- 2.4.1 Make sure the tow bar is securely attached to the towing vehicle.
- 2.4.3 Maximum allowable towing speed is 15 MPH.

2.5 Parking Brake

- 2.5.1 Parking brake must be applied when filling and draining or when left unattended.

2.6 Air Supply

- 2.6.1 **CAUTION:** Check the air pressure of supply lines to the vacuum generator to assure it is not in excess of 100 PSI.

2.7 Inspections

2.7.1 Inspections of tires, undercarriage, tow bar, vent, valves, hoses, sight gauge, reflectors, safety labels, etc., should be inspected on a periodic basis. It is recommended these inspections be performed weekly.

2.7.2 Internal inspection will be necessary to insure structural integrity and cleanliness. It is recommended that interval inspections be performed at least every six- (6) months.

CAUTION: When entering confined spaces such as the interior of the bowser tank, care should be taken to provide proper breathing equipment and a separate person dedicated solely to a safety watch of the person inside. It is strongly recommended that all local or other regulations be consulted.

2.8 Manway

2.8.1 Insure the manway cover is provided with a "lock out" devised to prevent accidental closing of the manway while doing internal inspections and to prevent unwanted elements from being introduced to the fuel supply.

2.9 Hoses

2.9.1 Inspect hoses daily prior to usage. The hoses should be extended, as it normally would be for operating. Check for evidence of blistering, carcass saturation or separation, cuts, nicks or abrasions that expose reinforcement materials. Look for slippage, misalignments or leaks at the couplings; if coupling slippage or leaks are found the cause of the problem shall be determined. All defective hoses should be removed from service.

2.10 Reserved for future use.

2.11 Reserved for future use.

2.12 Vacuum Governor

2.12.1 The vacuum fuel bowser is provided with a pre-adjusted vacuum governor. See Maintenance for adjusting.

3.0

Operations

3.1 Intended Use

3.1.1 The vacuum fuel bowser unit is intended for use in draining and collection of fuel from aircraft or storage area and then transportation to the aircraft, storage area or disposal site. Any other use is prohibited and may void any and all warranties.

3.2 Tow Bar and Undercarriage

3.2.1 The vacuum fuel bowser unit is equipped with steering front wheels controlled by the tow bar.

3.2.2 Care should be taken not to jackknife the bowser when backing up.

3.2.3 Tire inflation should be checked and maintained as described in the "Maintenance Section".

3.2.4 Before towing, check to see that the grounding reel, air lines and hoses are disconnected, and valves are closed, tow bar is securely attached to the towing vehicle and all manway and covers are closed and latched.

3.2.5 The vacuum fuel bowser unit is equipped with a tow bar latch to hold it in the upright position.

3.3 Parking Brake

3.3.1 The vacuum fuel bowser unit is equipped with a mechanical lever operated parking brake. The brake is applied when the brake handle is in the on position. The brake should be applied when filling, draining tank or whenever left unattended.

3.4 Manway

3.4.1 The vacuum fuel bowser unit is equipped with a quick opening manway assembly for internal inspections.

3.4.2 The manway is equipped with a flip locking cross arm assembly to ensure sealing and securing the cover lid in place.

3.5 Reserved for future use

3.6 Sample Port

3.6.1 Not used on this unit

3.7 Grounding

3.7.1 The vacuum fuel bowser unit is supplied with two (2)-grounding reels.

3.7.2 Before filling or draining, the grounding reels must be attached between the aircraft or object being serviced and an appropriate ground.

3.8 Drain Valve

3.8.1 The vacuum fuel bowser unit is equipped with a 1-1/2" NPT ball valve with a camlock connector.

3.9 Telescoping Drain Assembly

3.9.1 The vacuum fuel bowser is equipped with a telescoping drain assembly. It is capable of being adjusted to 8ft-0in to 16ft-0in.

3.9.2 The telescoping drain assembly can be fully isolated from the vacuum system via a lower shut off ball valve, located under the tank.

3.9.4 To Raise:

- (1) Loosen top clamp if necessary.
- (2) Grasp top section with one hand and lift as required.
- (3) Tighten clamp securely with the other hand.
- (4) Reposition lifting hand by grasping tube below tightened clamp and lift as required.
- (5) Repeat steps 1-4 until desired height is obtained or assembly is fully extended.

3.9.5 To Lower:

- (1) Tightly grasp bottom extended tube, with one hand loosen the securing clamp.
- (2) Slowly lower tube, hand over hand, until the following clamp is resting on the loosened clamp.
- (3) Repeat steps 1 and 2 until all sections are lowered.

3.9.4 Funnel is equipped with a nitrile rubber seal around the top edge to allow placement against the underside of the wing.

3.9.5 When not in use, telescoping funnel should be collapsed and the cover closed to eliminate contamination.

3.0 Operations (continued)

3.10 Telescoping Drain Sump

3.10.1 The Telescoping Drain assembly is equipped with a sump and drain coupling for cleaning.

3.11 Vacuum Assembly

3.11.1 This assembly is equipped with an air powered vacuum generator.

3.11.2 It is intended for vacuum draining or depuddling fuel and condensation. Caution! If other objects such as rock or metallic pieces are vacuumed into the vacuum chamber, they may create a hazard due to sparking.

3.11.3 Vacuum is started by attaching a recommended air supply of 60 CFM at 100 PSI and turning on the air supply valve.

3.11.4 The vacuum assembly is supplied with a vacuum hose and a ball valve on the vacuum suction outlet.

3.11.5 The vacuum assembly is equipped with (4) four each ½" NPT opening for use with pencil drains. To use, the pipe caps must be removed and self-closing quick disconnects attached that match local standards. To operate, close vacuum suction valve and turn air supply on and connect drain lines.

3.12 Vacuum Governor

3.12.1 The vacuum governor has been preset at the factory and needs no further adjustments. See "Maintenance" should adjustments or replacement be required.

4.0 Maintenance

4.1 Tow Bar and Under Carriage

4.1.1 The fuel bowser unit is equipped with steering front wheels, controlled by the tow bar and fixed rear wheels.

4.1.2 Maintenance should consist of the following:

- 1) Kingpin bushing, turning bushings and tie rod ends are self-lubricating and need no additional maintenance.
- 2) Inspect wheel bearings at three (3) month intervals. Repack and/ or replace as needed.
- 3) Check tire pressure weekly. Maintain pressure as per tire markings.

4.1.3 Tow bar pivot pin and hook ring should be inspected monthly for excessive wear or cracks.

4.2 Parking Brake

4.2.1 The fuel bowser unit is equipped with a parking brake assembly consisting of a brake drum and brake shoes.

4.2.2 The shoes are activated via a mechanical linkage, eccentric and lever.

4.2.3 The brakes are applied when the brake handle is in the on position. The brakes release when the brake handle is in the off position.

4.2.3 Adjustment may be necessary as the shoes wear.

- 1) Tightening is accomplished by removing the bolt through one yoke and screwing yoke to shorten/lengthen connecting rod as required.
- 2) Do not over tighten or brakes may drag when released.

4.2.4 Brake Shoe Replacement

- 1) Remove wheel.
- 2) Remove nut retaining hub and drum assembly.
- 3) Disconnect actuating rod.
- 4) Remove shoe retainers.
- 5) Install new shoes.
- 6) Replace shoe retainers.
- 7) Adjust actuator rod length.
- 8) Replace wheel.

4.3 Manway

4.3.1 Inspect manway gasket weekly for cuts, cracks or galling. Replace as needed.

4.4. Reserved for future use

4.5. Reserved for future use

4.6 Grounding

4.6.1 Grounding reel cables should be pulled out, cleaned and inspected monthly.

- 4.6.2 Cable clamps and ends should be inspected for loose connections monthly.
- 4.7 Telescoping Drain Assembly
 - 4.7.1 The telescoping drain assembly consists of a stainless steel housing permanently attached to the tank and multiple aluminum tube sections.
 - 4.7.2 The stainless tube and aluminum sections are equipped with a clamp assembly.
 - 4.7.3 Each aluminum section is crimped on the lower end of the tubing, which acts as a stop to prevent the tube from sliding through the clamp.
 - 4.7.4 Disassembling of the funnel sections are accomplished by rotating the three (3) sections 180 degrees from normal position and gently lifting each section so that the crimped edge on the tube is aliend with the slot on the clamp.
- 4.8 Telescoping Drain Sump
 - 4.8.1 The fuel bowser is provided with a sump assembly located directly under the telescoping assembly.
 - 4.8.2 Drain the bowser and the sump prior to servicing.
 - 4.8.2 Maintenance should consist of inspection and cleaning monthly.
- 4.9 Vacuum Assembly
 - 4.9.1 The vacuum assembly consists of a vacuum chamber with an air powered vacuum generator mounted on a removable cover. The cover is held in place by three (3) latches.
 - 4.9.2 The vacuum chamber is equipped with a diagonal drain trough to prevent splashing of the fuel into the bowser unit.
 - 4.9.3 The vacuum cover is equipped with an overflow valve which should require no maintenance.
 - 4.9.4 The vacuum generator is attached to the chamber cover. The generator is equipped with an exhaust silencer which should be cleaned at six (6) month intervals or more often depending on the amount of use and conditions.

4.0 Maintenance (continued)

4.9.5 The vacuum hose should be inspected monthly for cracks. Any sudden loss of vacuum suction power may indicate a crack in the vacuum hose.

4.9.6 The cover gasket should be inspected monthly for deterioration. This gasket should be pliable and free from weather checking.

4.9.7 The overflow stop pivot bolt should not be over tightened. Over tightening will restrict motion of the float.

4.10 Vacuum Governor

4.10.1 The vacuum governor has been preset at the factory and should need no further adjustments.

4.10.2 Should Adjustments be Required:

(1) A ½" nipple on the lid of the vacuum pot is provided for the attachment of a vacuum gauge.

(2) The air supply must be started from 0 pressure and slowly opened while simultaneously adjusting the vacuum governor until you reach the desired operating range.

CAUTION: (2) The governor **must not** be adjusted outside of the designed operating range and to do so may damage the tank and/or the rupture disk may burst. Improper adjustments will nullify the factory warranty.

4.11 Reserved for future use.

4.12 Trouble Shooting

<u>SYMPTOM</u>	<u>PROBABLE CAUSE</u>	<u>PROBABLE CORRECTIONS</u>
Bowser does not track or steer	Bent king pin housing	Replace king pin housing see section 5.2.1 Item #7
	Defective tie rod end	Replace tie rod end See section 5.2.1 Item #12
	Loose or worn out bushings	Replace as needed see section 5.2.1 item #11 #16 or #18
Tow bar does not stay in the up-right position	Broken or stretched spring	Replace as needed see section 5.2.1 item #26

4.0 Maintenance (continued)

4.12 Trouble Shooting (continued)

<u>SYMPTOM</u>	<u>PROBABLE CAUSE</u>	<u>PROBABLE CORRECTIONS</u>
Parking brake does not work	Need adjustment or repairing	Adjust or replace as per instructions. See section 4.2 and 5.2.3-B

5.0 Replacement Parts

This section provides information for identification of parts for ordering. To Order, it is important to have the Model Number, Subassembly Number, Part Number and Description. Parts may be ordered by calling or writing to:

Spokane Industries, Inc.
Spokane Metal Products Division
P.O. Box 3303
Spokane, WA 99220-3303
Telephone: (509) 928-0720
Tele Fax: (509) 927-0826
[Http://www.SpokaneIndustries.com](http://www.SpokaneIndustries.com)

Reproduction of this data or the manufacturing of products from this data by anyone other than Spokane Metal Products of Spokane, WA is strictly prohibited without written consent.

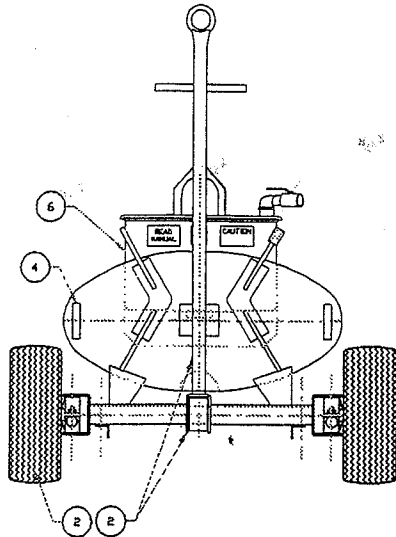

FRONT VIEW

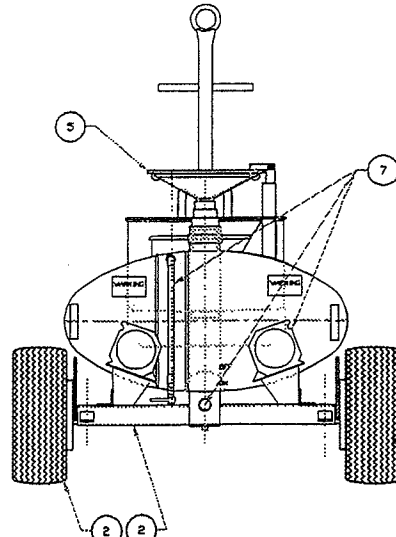

REAR VIEW

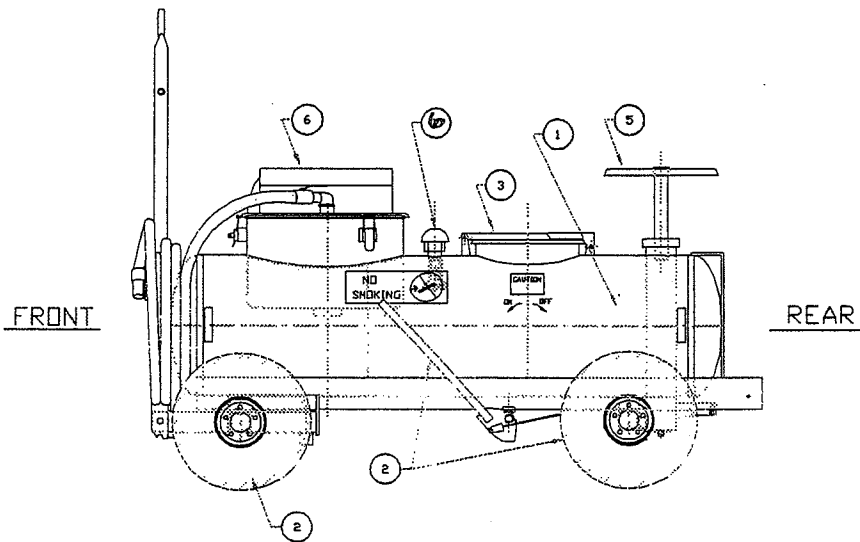

<u>Item No.</u>		<u>Section</u>
1	Main Tank	5.1
2	Axle, Front	5.2.1
2	Axle, Rear	5.2.2
2	Brake, Parking	5.2.3
2	Wheel Assembly, Front	5.2.4
2	Wheel Assembly, Rear	5.2.5
3	Manway Assembly	5.3
4	Decal Package	5.4
5	Telescoping Drain	5.5
5	TELESCOPING DRAIN SUMP	5.5.1
6	Vacuum Assembly	5.6
6	VACUUM GOVERNOR ASSEMBLY	5.6.1
7	Miscellaneous Fixtures	5.7
8	Reserved for future use	5.8

CONFIDENTIAL-PROPRIETARY INFORMATION
 REPRODUCTION OF THESE DRAWINGS OR THE
 MANUFACTURING OF PRODUCTS FROM THESE
 DRAWINGS FOR USE BY ANYONE OTHER THAN
 SPOKANE INDUSTRIES INC. OF SPOKANE, WA
 IS STRICTLY PROHIBITED WITHOUT WRITTEN
 CONSENT

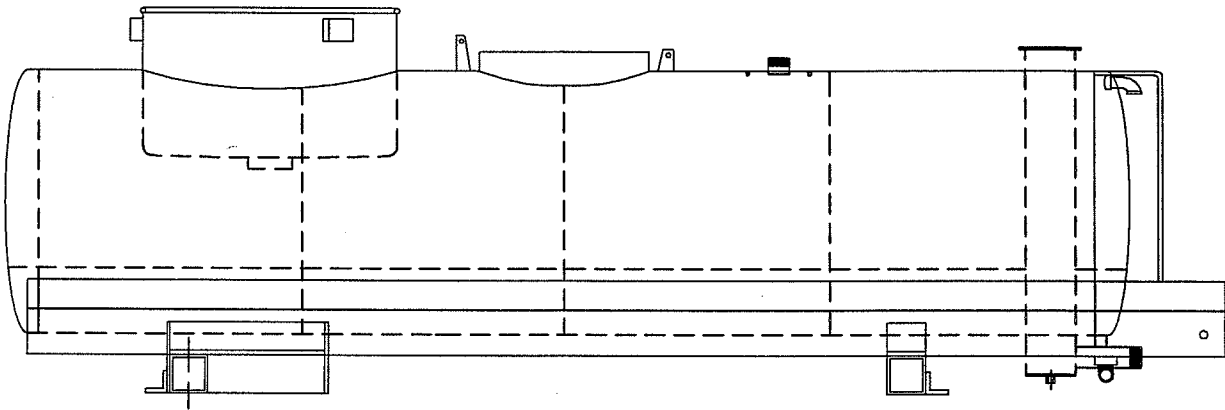

SECTION 5.1.0
 ASSEMBLY NO. 08-10009
 MAJOR ASSEMBLY-TANK WELDMENT

<u>Sub Assy</u>	<u>Item</u>	<u>Part No.</u>	<u>Quantity</u>	<u>Description</u>	<u>WT.#</u>
	1	SMP-18450	1	Stainless Steel Tank Weldment, 400 Gallon Capacity Series BOW 400-06	687#

CONFIDENTIAL INFORMATION
 REPRODUCTION OF THESE DRAWINGS OR THE MANUFACTURING
 OF PRODUCTS FROM THESE DRAWINGS FOR USE BY ANYONE
 OTHER THAN SPOKANE METAL PRODUCTS OF SPOKANE, WA
 IS STRICTLY PROHIBITED WITHOUT WRITTEN CONSENT.

SECTION 5.2.1

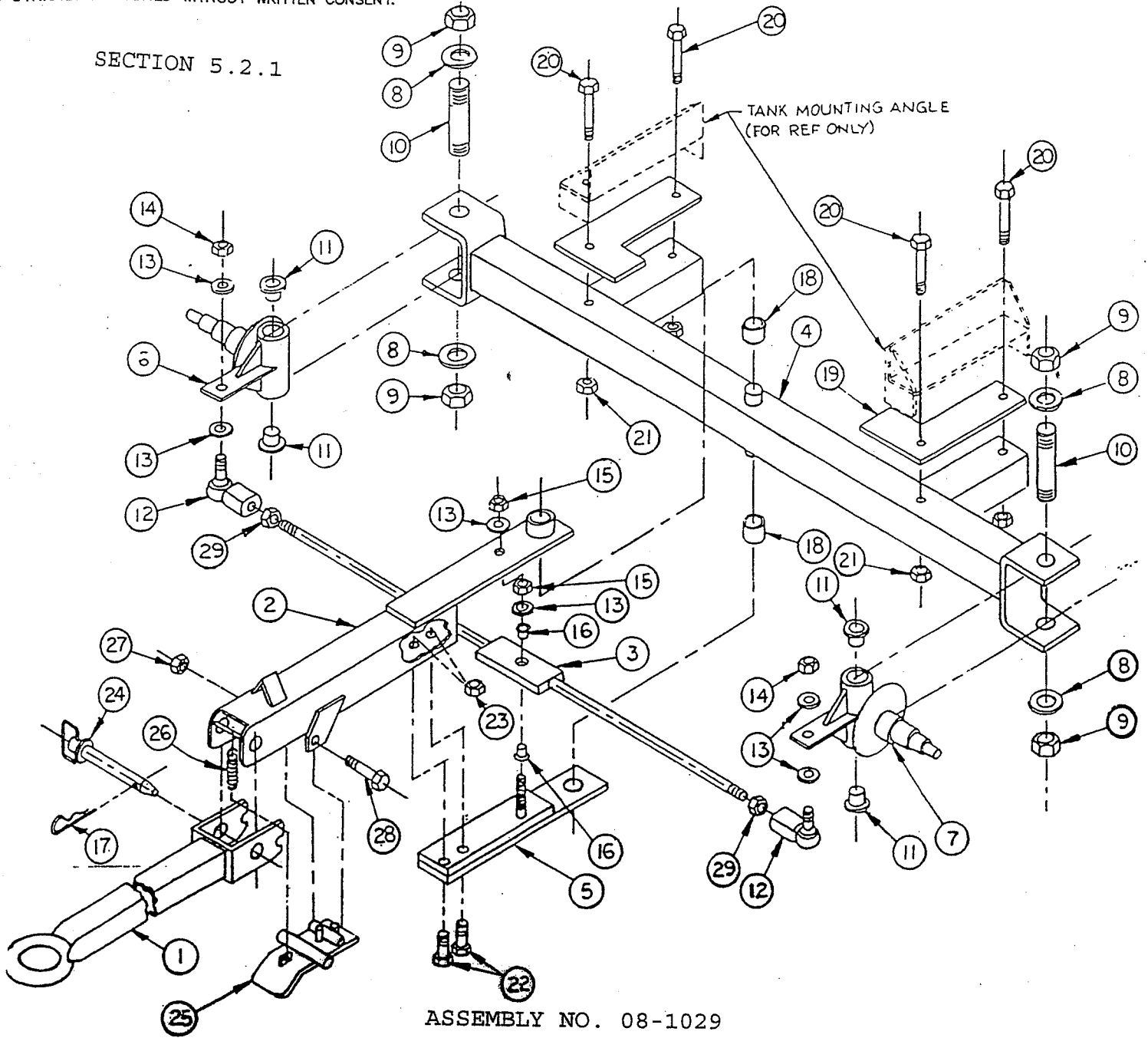

ASSEMBLY NO. 08-1029

MAJOR ASSEMBLY - AXLE ASSEMBLY

Sub Assy.	Item	Part No.	Quantity	Description	Wt.#
08-1029				Axle, Assembly, Front	
	1	07-1103	1	Tow Bar	23
	2	07-1052	1	Arm, Turning	16
	3	07-10371	1	Tie Rod	7.3
	4	07-1053	1	Axle, Front	53

MAJOR ASSEMBLY - AXLE ASSEMBLY (CONTINUED)

Sub Assy.	Item	Part No.	Quantity	Description	Wt.#
	5	07-1046	1	Steering Arm, Lower Plate	6.1
	6	07-1009	1	Sleeve, King Pin, Right	24
	7	07-1009	1	Sleeve, King Pin, Left	24
	8	02-11131	4	Washer, King Pin	1
	9	02-12131	4	Nut, King Pin	2
	10	05-1010	2	King Pin	11
	11	03-1013	4	Bushing, King Pin Sleeve	1
	12	03-1016	2	Ends, Tie Rod	5
	13	02-11072	5	Washers, Tie Rod	
	14	02-12071	2	Nuts, Tie Rod Ends	1
	15	02-12071	1	Nut, Tie Rod Pivot	.5
	16	03-1015	2	Bushing, Tie Rod Pivot	.8
	17	02-1300	2	Cotter Pin	.2
	18	03-1014	2	Bushing, Axle Pivot	1
	19	06-1023	2	Mounting Pad, Tank	4
	20	02-1503	4	Bolts, Tank Mounting	1.3
	21	02-12041	4	Nuts, Tank Mounting	.5
	22	02-1502	2	Bolts, Turning Arm Clamp	.32
	23	02-12041	2	Nuts, Turning Arm Clamp	.2
	24	02-1304	1	Hitch Pin	2
	25	07-1020	1	Toe Latch	3.1
	26	04-1054	1	Spring, Toe Latch	.5
	27	02-12012	1	Nut, Toe Latch	.1
	28	02-1501	1	Bolt, Toe Latch	.2
	29	02-12141	2	Hex Nut, Tie Rod	.2

CONFIDENTIAL PROPRIETARY INFORMATION
Reproduction of this data or the manufacturing of products from
this data by anyone other than Spokane Metal Products of
Spokane, WA is strictly prohibited without written consent.

SECTION 5.2.2

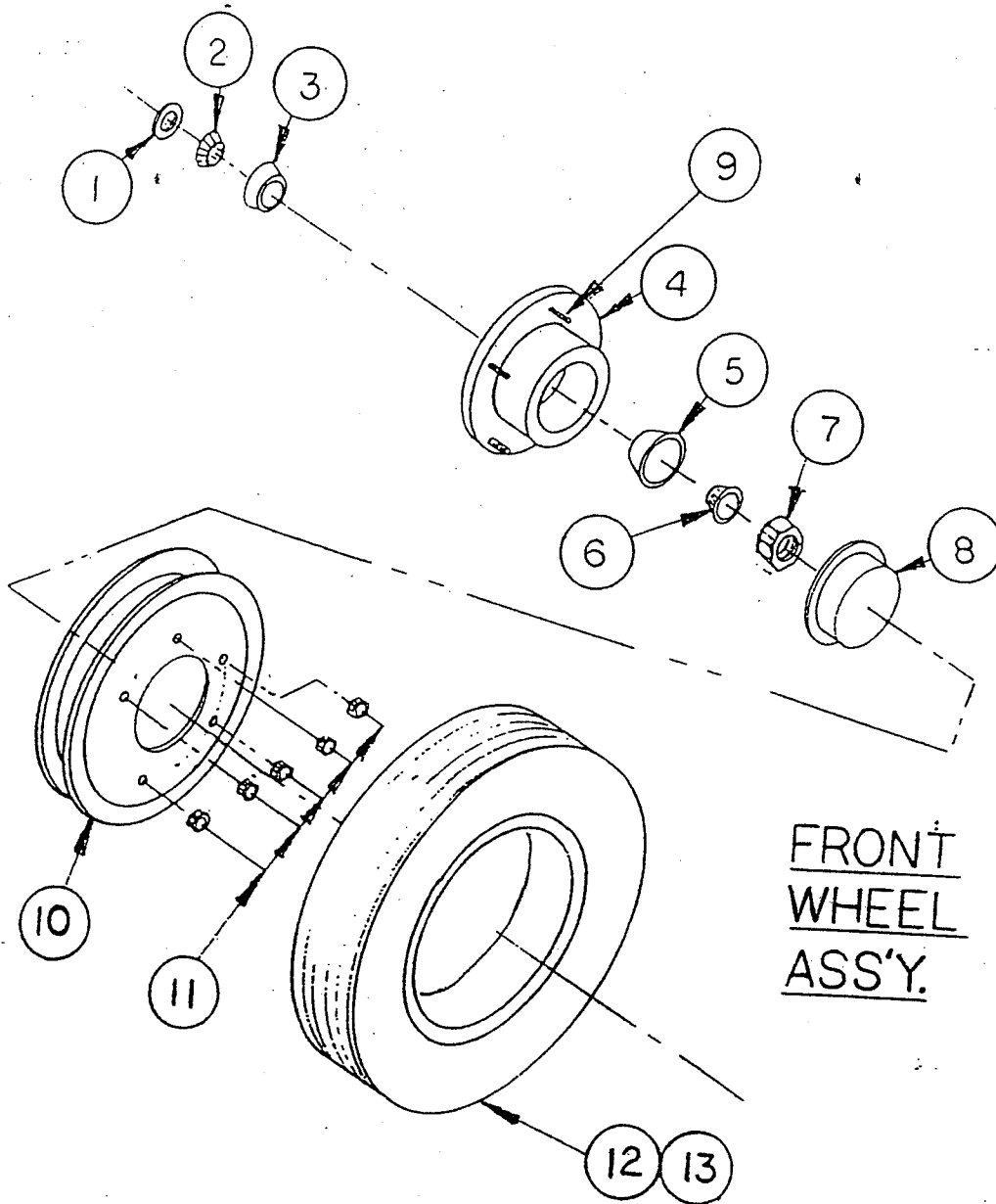

MAJOR ASSEMBLY - WHEEL ASSEMBLY, FRONT

Sub Assy.	Item	Part No.	Quantity	Description	Wt.#
08-1011		04-1050		Bearing & Hub Assembly (2 Reqd)	
	1	04-1012	1	Seal, Bearing	1
	2	04-1013	1	Bearing, Inner	3
	3	04-1015	1	Cup, Inner	2
	4	04-1017	1	Hub, Wheel	7
	5	04-1016	1	Cup, Outer	4
	6	04-1014	1	Bearing, Outer	3
	7	02-1205	1	Spindle Nut	1
	8	04-1019	1	Dust Cap	1
	9	02-1017	5	Studs, Hub	1
08-10061		04-10201		Tire/Wheel/Tube Assembly (2 Reqd)	
	10	04-1020	1	Wheel, Split Rim, 10"	9.5
	11	04-1021	5	Lug Nuts, Wheel	1
	12	04-10221	1	Tire, 10"	4
	13	04-1045	1	Tube Assembly	11

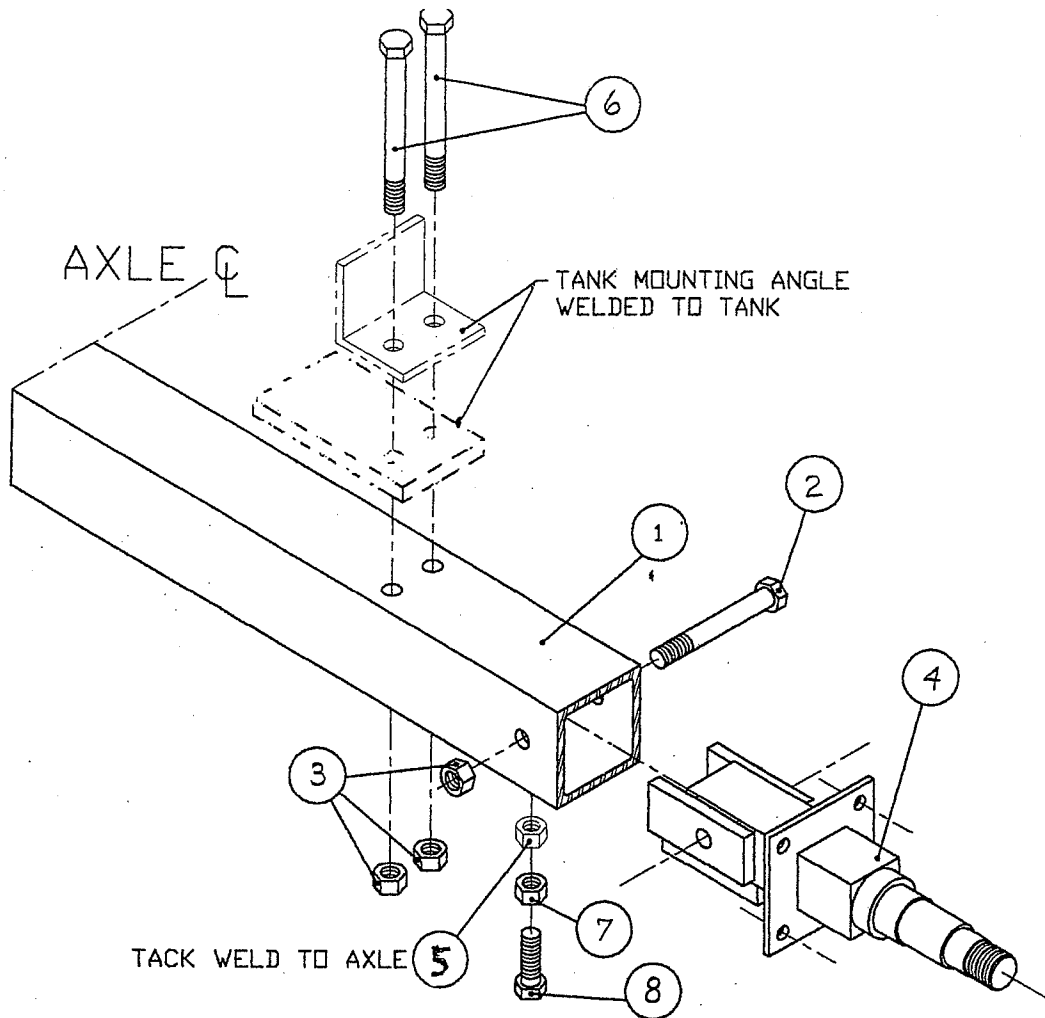

ASSEMBLY NO. 08-1030ZR2
 SECTION 5.2.3
 MAJOR ASSEMBLY - AXLE ASSEMBLY

Sub. Assy.	Item	Part No.	Qty.	Description	Wt.
08-1030ZR				Axle Assembly, Rear	
	1	05-1054	1	Axle, Rear Weldment	40
	2	02-1505	2	Bolts, Mounting Spindle	.6
	3	02-12041	2	Nuts, Mounting Spindle	.5
	4	07-1010R	2	Spindle, Rear	17
	5	02-12035	1	NUT, JAM	.1
	6	02-1503	4	Bolt, Tank Mounting	1.3
	7	02-1203	4	Nuts, Tank Mounting	.5
	8	02-10041	2	Bolt, Spindle Stabilizer	.5

SECTION 5.2.4

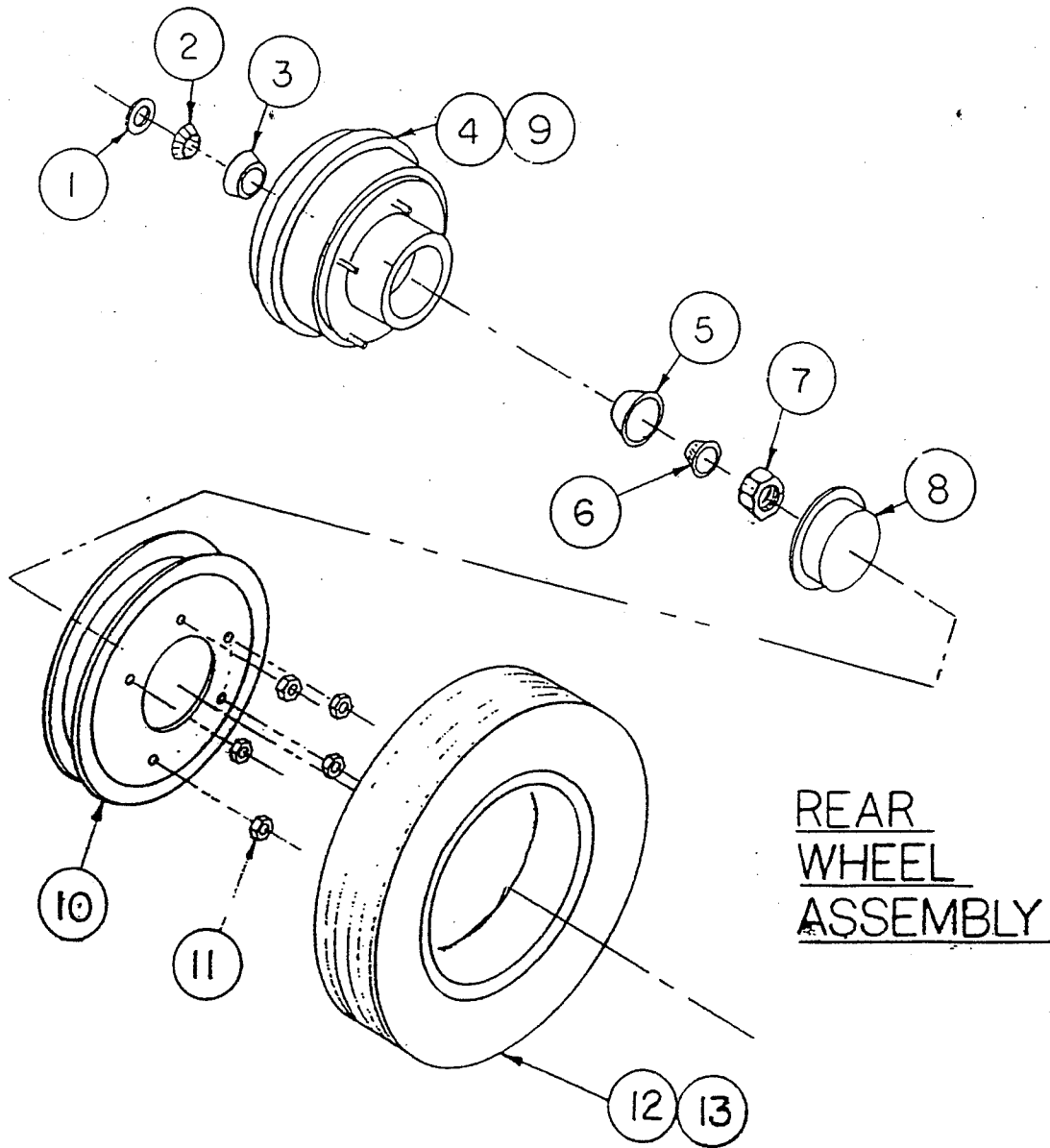

MAJOR ASSEMBLY - WHEEL ASSEMBLY, REAR

Sub Assy.	Item	Part No.	Quantity	Description	Wt.#
08-10111R		04-1062R		Bearing & Hub Assembly (2 Req'd)	
	1	04-1012	1	Seal, Bearing	1
	2	04-1013	1	Bearing, Inner	3
	3	04-1015	1	Cup, Inner	2
	4	05-1008R	1	Hub/Brake Drum Sub-Assy	16
	5	04-1016	1	Cup, Outer	4
	6	04-1014	1	Bearing, Outer	3
	7	02-1205	1	Nut, Spindle	1
	8	04-1019	1	Dust Cap	1
08-10061		04-10201		Tire/Wheel/Tube Assembly (2 Req'd)	
	10	04-1020	1	Wheel, Split Rim	9.5
	11	04-1021	5	Lug Nuts, Wheel	1
	12	04-10221	1	Tire, 10"	4
	13	04-1045	1	Tube Assembly	11

SECTION 5.2.5

CONFIDENTIAL-PROPRIETARY INFORMATION
REPRODUCTION OF THESE DRAWINGS OR THE MANUFACTURING OF PRODUCTS FROM THESE
DRAWINGS FOR USE BY ANYONE OTHER THAN SPOKANE INDUSTRIES INC. OF SPOKANE, WA
IS STRICTLY PROHIBITED WITHOUT WRITTEN CONSENT

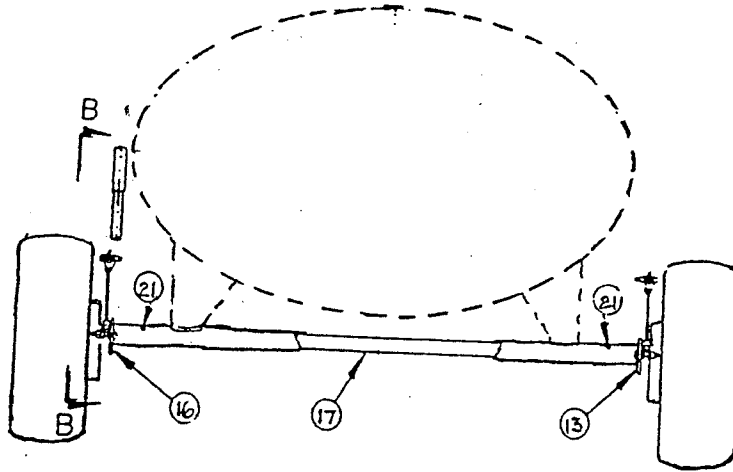

REAR VIEW

NTS

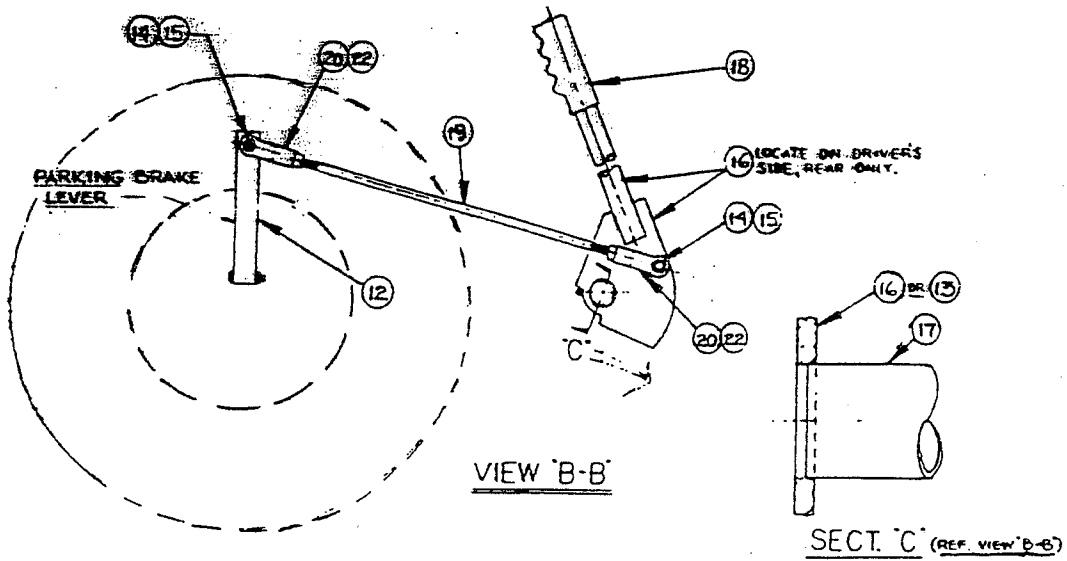

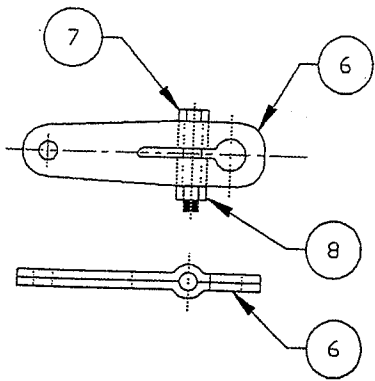

CAM LEVER OPERATOR DETAIL

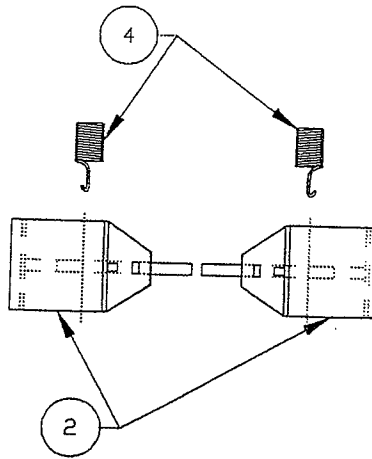

BRAKE SHOE / HOLD DOWN SPRING DETAIL

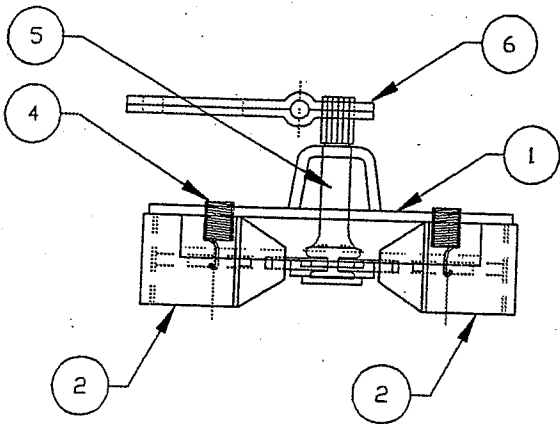

BRAKE/CAM/LEVER/BACKING PLATE ASSY

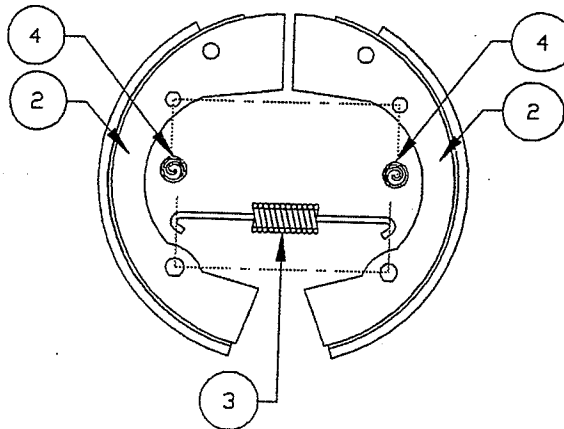

BRAKE SHOE / SPRING ORIENTATION
RETURN SPRING

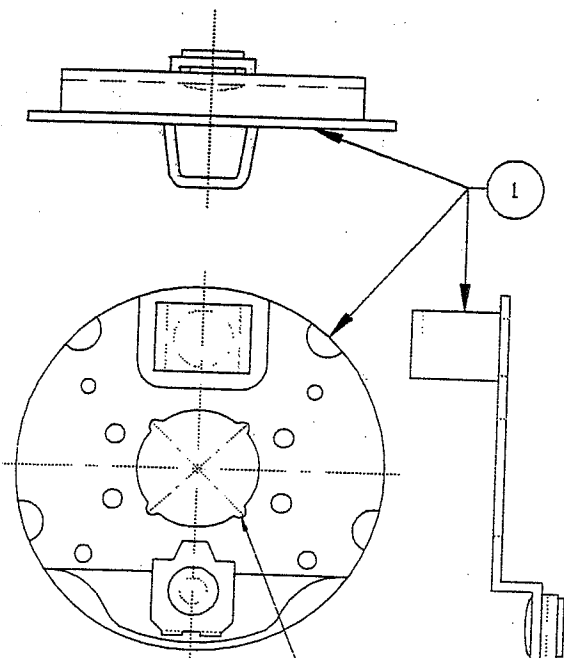

BACKING PLATE DETAIL

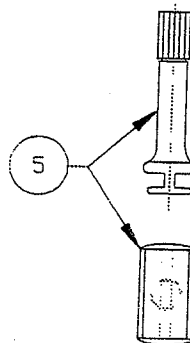

CAM DETAIL

SECTION 5.2.3

CONFIDENTIAL-PROPRIETARY INFORMATION
REPRODUCTION OF THESE DRAWINGS OR THE MANUFACTURING OF PRODUCTS FROM THESE
DRAWINGS FOR USE BY ANYONE OTHER THAN SPOKANE INDUSTRIES INC. OF SPOKANE, WA
IS STRICTLY PROHIBITED WITHOUT WRITTEN CONSENT

ASSEMBLY No. 10-100030R
MAJOR ASSEMBLY - BRAKE, PARKING

Sub Assy.	Item	Part No.	Quantity	Description	Wt. #
08-1007R		04-1063		Brake Assembly (2 Req.)	4.4
	1	04-1064R	1	Backing Plate Assembly	1.4
	2	04-1065R	2	Brake Shoe Assembly	1.6
	3	04-10265R	1	Return Spring	.04
	4	04-1026R	2	Hold Down Spring	.06
	5	04-1028R	1	Cam	.5
	6	04-1030R	1	Cam Lever	.7
	7	02-10017R	1	Cam Bolt	.07
	8	02-12012	1	Cam Nut	.03
	9				
	10				
	11				
	12				
08-1008				Brake Linkage Assembly	14.8
	13	05-1025	1	Cam, Brake Linkage	1.4
	14	02-10012	1	Bolt	.4
	15	02-12021	1	Nut	.1
	16	07-1033	1	Brake Handle, Fab'd Sub Assy	5.4
	17	01-8104	1	Brake Handle, Connector	4
	18	04-1055	1	Grip, Vinyl	1
	19	05-1026	1	Rod, Brake Linkage	1
	20	04-2516	4	Yoke Ends	.5
	21	03-1020	2	Grease Fitting	.5
	22	02-100231	4	Jam Nut	.5

CONFIDENTIAL-PROPRIETARY INFORMATION
 REPRODUCTION OF THESE DRAWINGS OR THE
 MANUFACTURING OF PRODUCTS FROM THESE
 DRAWINGS FOR USE BY ANYONE OTHER THAN
 SPOKANE INDUSTRIES INC. OF SPOKANE, WA
 IS STRICTLY PROHIBITED WITHOUT WRITTEN
 CONSENT

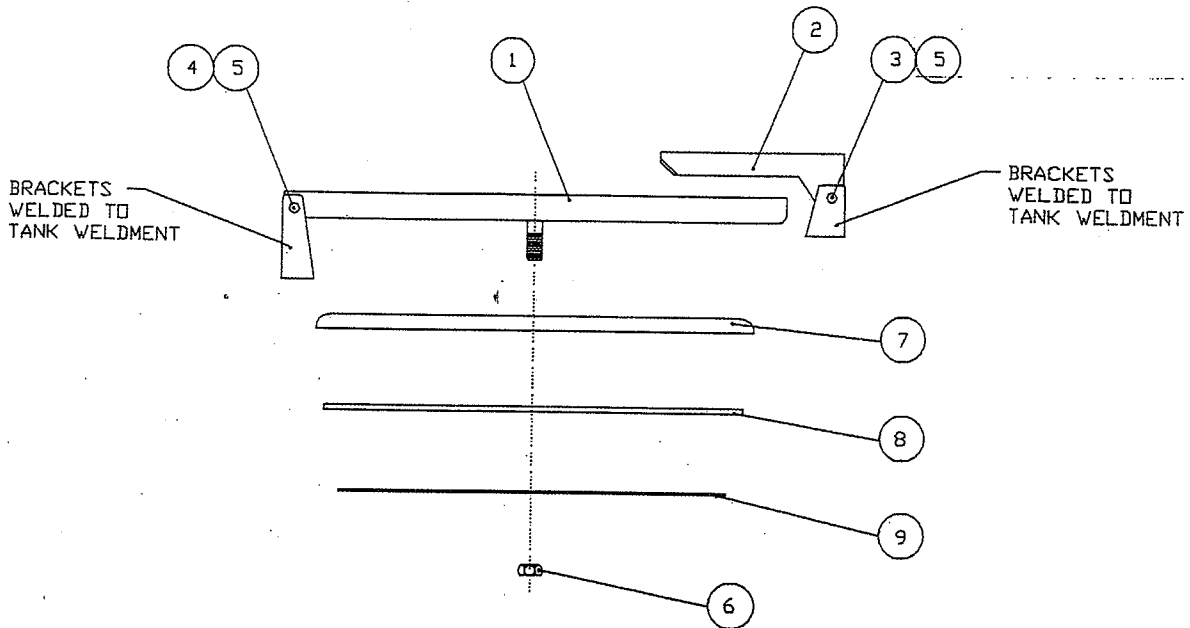

SECTION 5.3

ASSEMBLY NO. 10-100060

MAJOR ASSEMBLY - MANWAY ASSEMBLY

Sub Assy.	Item	Part No.	Quantity	Description	Wt.#
07-2102				Manway Cover Assembly	
	1	07-1039S	1	20" Cross Arm S/S Sub-Assy	2.5
	2	01-8222S	1	7" Cross Arm S/S	1
	3	02-10014	1	Bolt, 3/8"-UNC S/S	.5
	4	02-10013	1	Bolt, 3/8"-UNC S/S	.4
	5	02-1202	2	Nut, Nylon Lock, 3/8-UNC S/S	.1
	6	02-1206	1	Nut, Nylon Lock, 5/8"-NF S/S	.2
01-86001	7	01-86001	1	Cover, Manway Lid S/S	6
06-25025	8	06-25025	1	Gasket, Manway, Buna-N	1
	9	07-2303	1	Gasket Retainer, Alum	1

CONFIDENTIAL-PROPRIETARY INFORMATION
REPRODUCTION OF THESE DRAWINGS OR THE MANUFACTURING
OF PRODUCTS FROM THESE DRAWINGS FOR USE BY ANYONE
OTHER THAN SPOKANE METAL PRODUCTS OF SPOKANE, WA
IS STRICTLY PROHIBITED WITHOUT WRITTEN CONSENT.

SECTION 5.4

FRONT

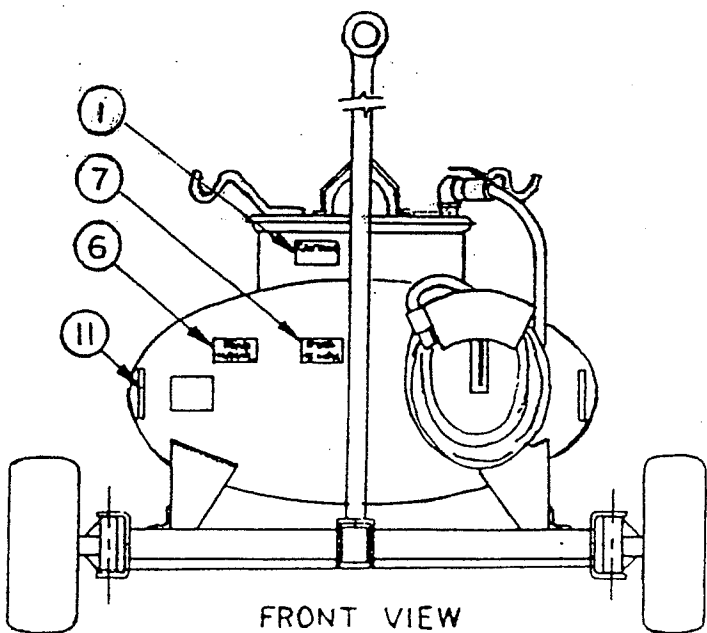
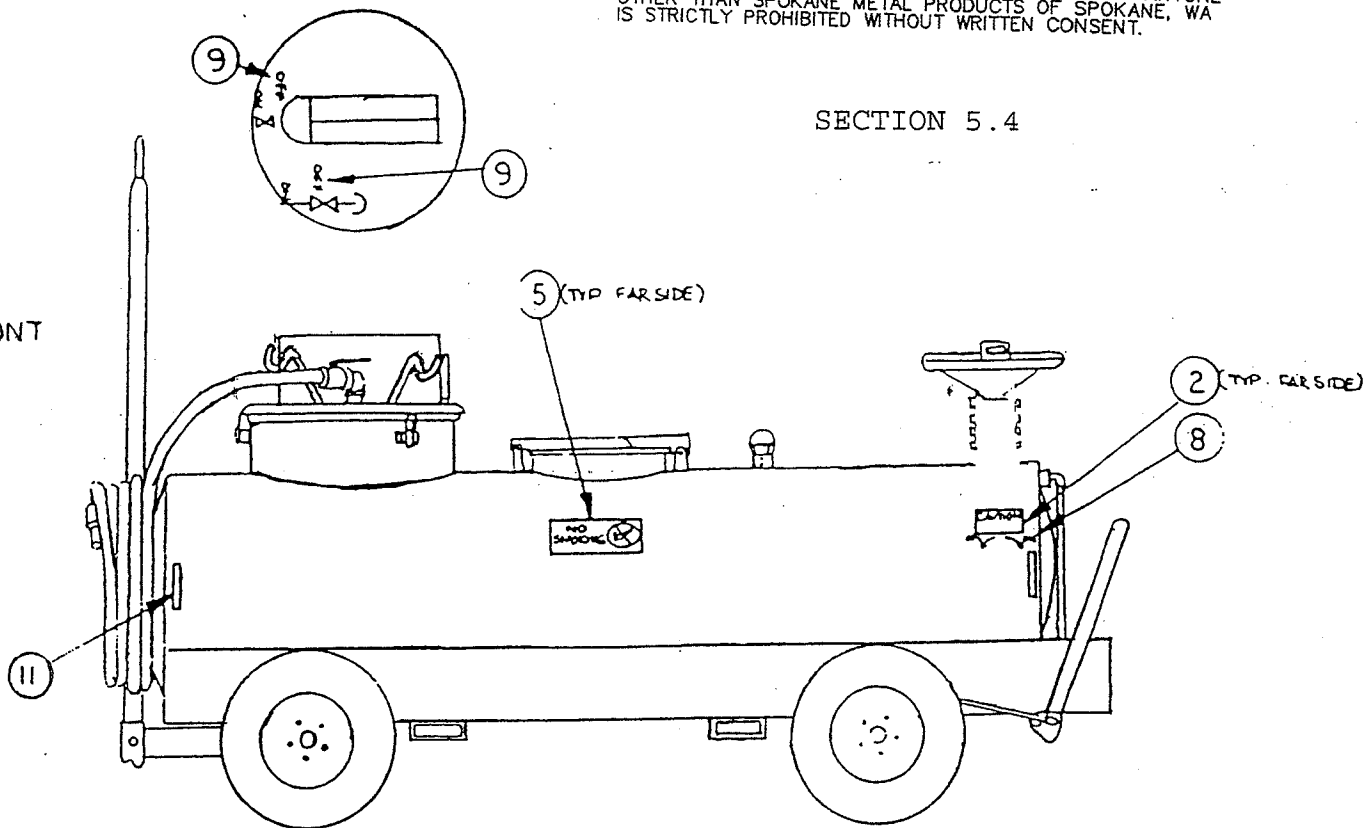

FRONT VIEW

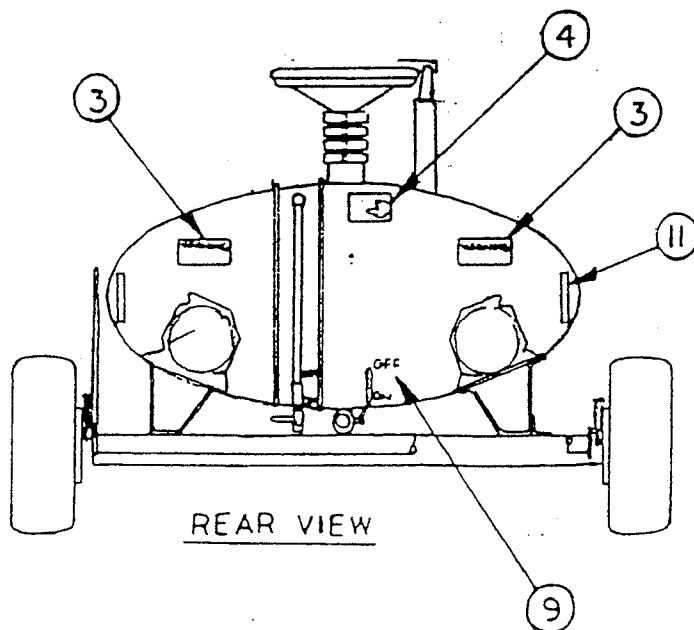

REAR VIEW

MAJOR ASSEMBLY - DECAL PACKAGE

Sub Assy.	Item	Part No.	Quantity	Description	Wt.#
10-100070				Decal Assembly	.1
	1	06-1002	1	Caution, Vacuum System	.1
	2	06-1003	1	Caution, Parking Brake	.1
	3	06-1004	2	Warning, Grounding Reels	.1
	4	06-1005	1	Warning, Telescoping Drain	.1
	5	06-1006	2	Danger, No Smoking	.2
	6	06-1007	1	Notice, Read Manual	.1
	7	06-1008	1	Maximum Towing Speed 15MPH	.1
	8	06-1010	1	Off/On, Parking Brake	.1
	9	06-1011	8	Off/On, Drain Valve	.8
*	11		8	Reflector Tape	.8

* = ITEMS NOT SHOWN

REPRODUCTION OF THESE DRAWINGS OR THE MANUFACTURING OF PRODUCTS FROM THESE DRAWINGS FOR USE BY ANYONE OTHER THAN SPOKANE METAL PRODUCTS OF SPOKANE, WA IS STRICTLY PROHIBITED WITHOUT WRITTEN CONSENT.

SECTION 5.5

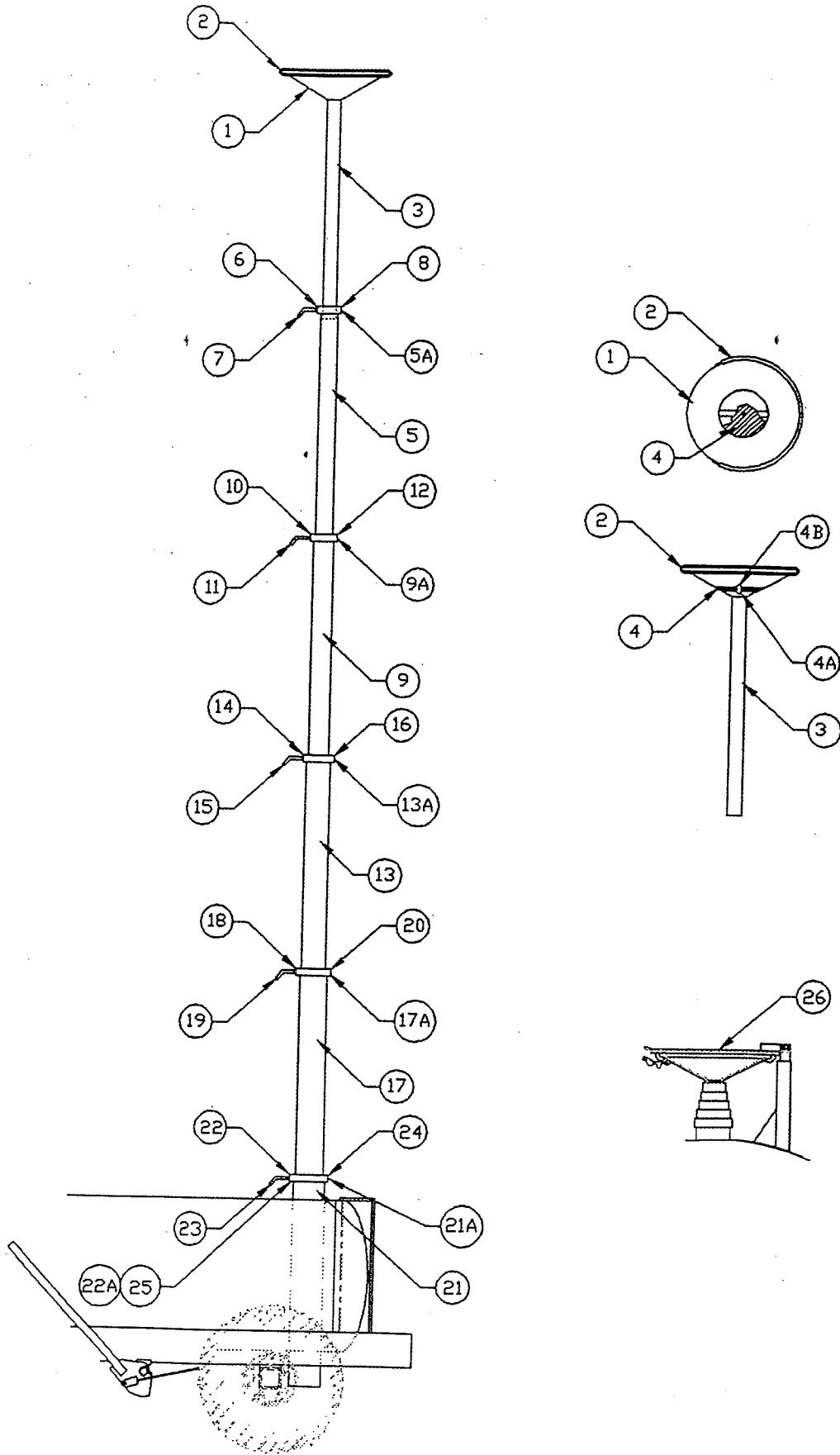

TELESCOPING DRAIN ASSEMBLY

Sub Assy.	Item	Part No.	Quantity	Description	Wt.#
07-10541				Drain Funnel Section Assembly	
	1	01-8250	1	Drain, Top (Funnel)	5
	2	06-1022	1	Gasket	.7
	3	01-92402	1	Tubing, 2" OD	1.5
	4	04-1039	1	Screen	.5
	4A	02-10002	1	Bolt, 1 1/4"	.2
	4B	02-1200	1	Nut, 1 1/4"	.1
08-1017U				Drain, Telescoping Section Assembly, 2 1/2" OD	
	5A	05-10271	1	Clamp, 2"	2
	5	01-9242	1	Tubing, 2 1/2" OD	1.5
	6	05-10051	1	Wedge, 1"x 11/16" x 1 1/4"	.3
	7	05-10181	1	Handle, Clamp	.3
	8	02-1005	1	Screw, Set	.01
08-1027U				Drain, Telescoping Section Assembly, 3" OD	
	9A	05-10281	1	Clamp, 2 1/2" OD	2.5
	9	01-92452	1	Tubing, 3" OD	1.7
	10	05-10021	1	Wedge, 1"x 7/8" x 1 9/16"	.3
	11	05-10181	1	Handle, Clamp	.3
	12	02-1005	1	Screw, Set	.01
08-1028U				Drain, Telescoping Section Assembly, 3 1/2" OD	
	13A	05-10291	1	Clamp, 3" OD	2.5
	13	01-9248	1	Tubing, 3 1/2" OD	1.9

TELESCOPING DRAIN ASSEMBLY

Sub Assy.	Item	Part No.	Quantity	Description	Wt.#
08-1028U Continued				Drain, Telescoping Section Assembly, 3 1/2" OD	
	14	05-10031	1	Wedge, 1"x1 1/16"x 1 13/16"	.3
	15	05-10181	1	Handle, Clamp	.3
	16	02-1005	1	Screw, Set	.01
07-1014U				Drain, Telescoping Section Assembly, 4" OD	
	17A	05-10301	1	Clamp, 3 1/2" OD	2.8
	17	01-9259	1	Tubing, 4" OD	2.1
	18	05-10041	1	Wedge, 1"x1 7/32"x 2 1/8"	.3
	19	05-10181	1	Handle, Clamp	.3
	20	02-1005	1	Screw, Set	.01
07-1041U				Drain, Telescoping Section Assembly, 4 1/2" OD	
	21A	05-10302	1	Base Clamp, 4" OD	3.0
	21	01-92565S	1	Tubing, 4 1/2" OD	2.3
	22	05-10051	1	Wedge, 1" x 1" x 2 1/2"	.3
	22A	04-10561	1	Flange, Base	.1
	23	05-10181	1	Handle, Clamp	.3
	24	02-1005	1	Screw, Set	.01
	25	02-100121	1	Mount Bolts, 1/4"-16x3/4"	.2
	26	08-1026A	1	Cover Assembly	5

CONFIDENTIAL-PROPRIETARY INFORMATION
 REPRODUCTION OF THESE DRAWINGS OR THE MANUFACTURING
 OF PRODUCTS FROM THESE DRAWINGS FOR USE BY ANYONE
 OTHER THAN SPOKANE METAL PRODUCTS OF SPOKANE, WA
 IS STRICTLY PROHIBITED WITHOUT WRITTEN CONSENT.

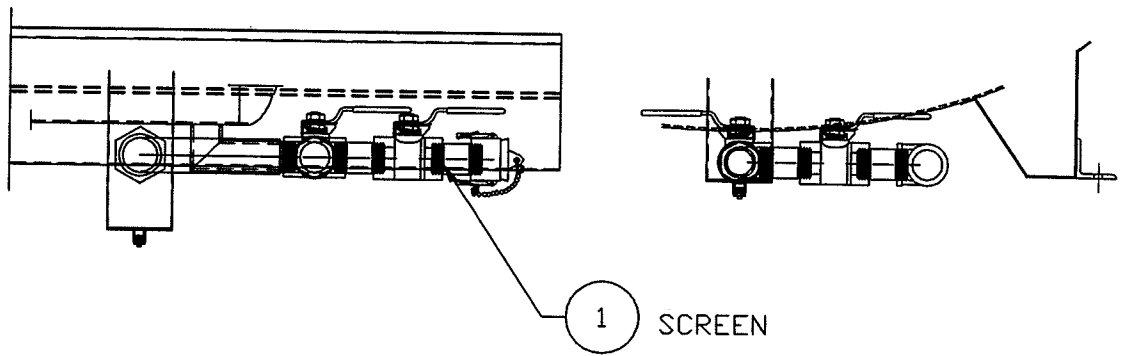
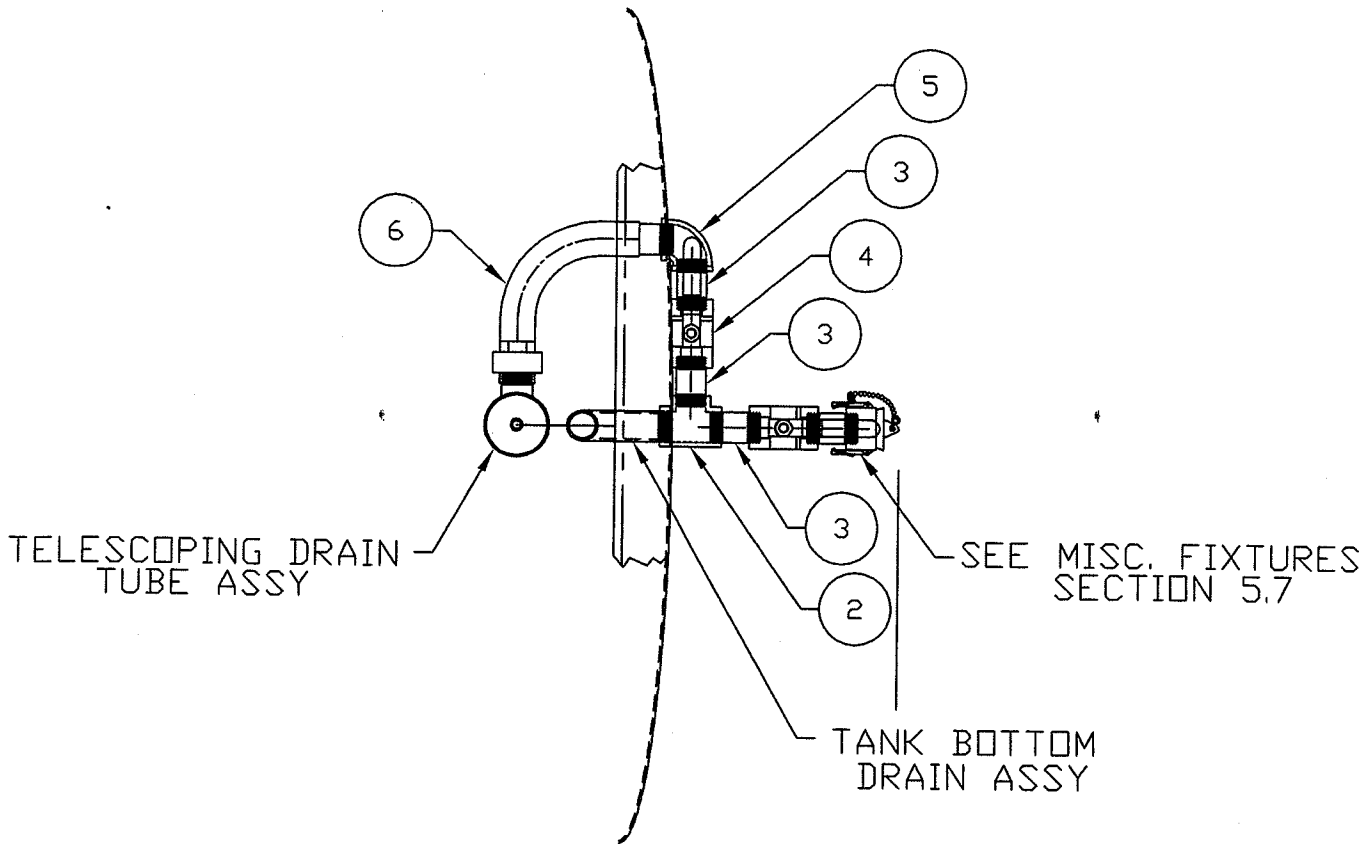

TELESCOPING DRAIN SUMP ASSY
 SECTION 5.5.1

6	1	P.D.	CONVELUTED TUBE ASSY, MNPT x UNION x 16 1/2"LG OAL	T304 S/S	4.2
5	1	P.D.	ELBOW, 1 1/2" FNPT 90°	T304 S/S	1.2
4	1	04-10321	VALVE, 1 1/2" BALL LOCKING HANDLE	BRASS	6.0
3	3	03-02921S	FULL NIPPLE, 1 1/2" SCH 40 x 3"LG	T304 S/S	2.0
2	1	P.D.	TEE, 1 1/2" FNPT 150#	T304 S/S	1.8
1	1	04-10393	SCREEN, FILTER, .016" WIRE, 20 x 20 MESH, 2 9/16"OD	T340 S/S	-
ITEM	QTY.	PART No.	DESCRIPTION	MAT'L.	WGHT.

Bill of Material

CONFIDENTIAL—PROPRIETARY INFORMATION
REPRODUCTION OF THESE DRAWINGS OR THE MANUFACTURING
OF PRODUCTS FROM THESE DRAWINGS FOR USE BY ANYONE
OTHER THAN SPOKANE METAL PRODUCTS OF SPOKANE, WA
IS STRICTLY PROHIBITED WITHOUT WRITTEN CONSENT.

SECTION 5.6

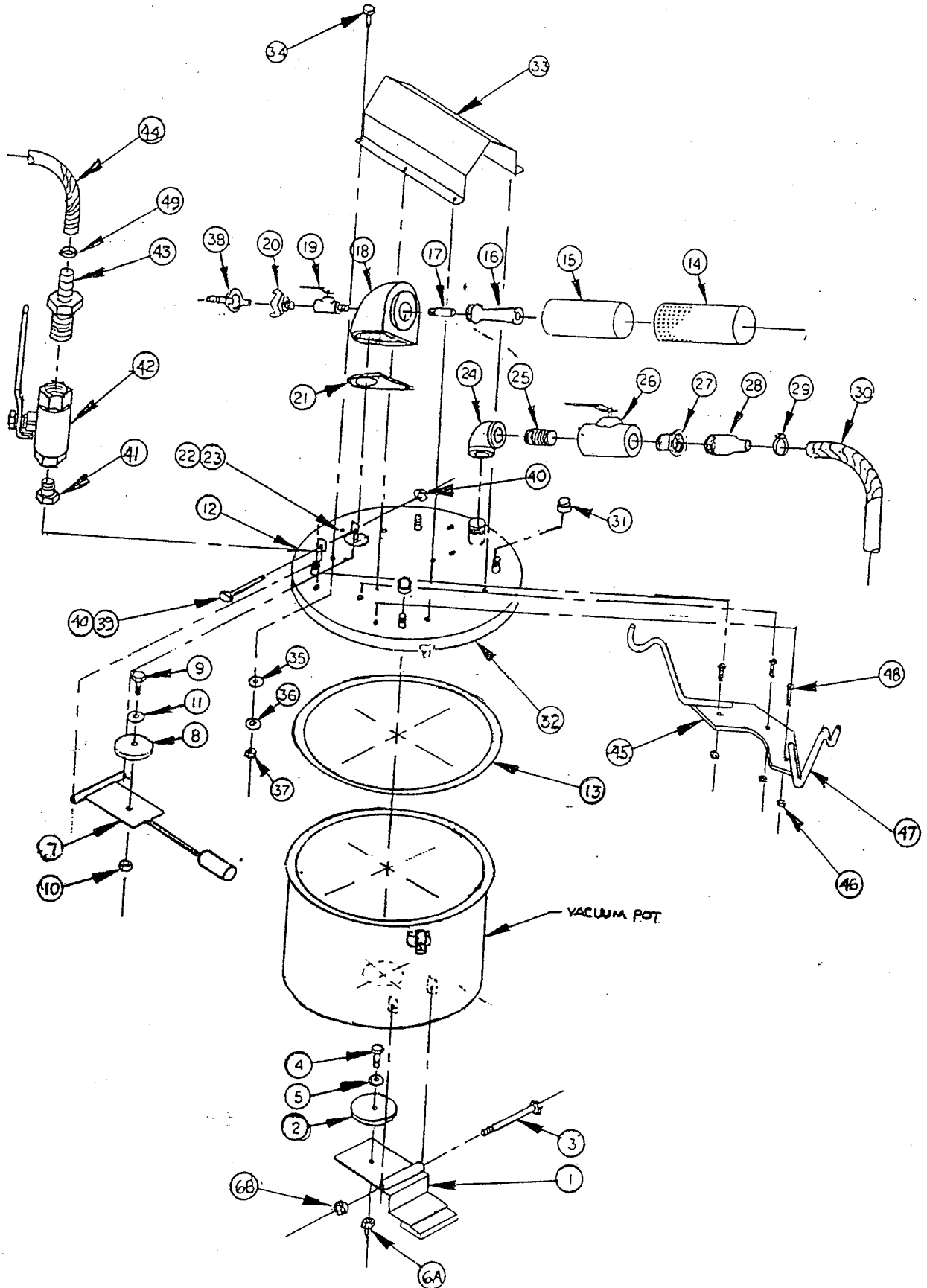

ASSEMBLY NO. 08-0001U (CONTINUED)
VACUUM SYSTEM ASSEMBLY

	23	02-11001	3	Washer	.1
08-1004				Accessories	
	24	03-1001	1	Elbow	2
	25	03-02922S	1	Nipple	.5
	26	04-10321	1	Valve	3
	27	03-1002	1	Hex Bushing	.2
	28	03-1003	1	Nipple	.1
	29	03-10101	1	Hose Clamp	.1
	30	06-10161	1	Hose	15
	31	03-1021	4	Pipe Cap (Optional)	1
	32	07-1019	1	Lid	24
	33	07-1034	1	Cover, Vacuum Generator	8
	34	02-10010	6	Bolt	.1
	35	06-1021	6	Washer	.1
	36	02-1100	6	Washer	.1
	37	02-1200	6	Nuts	.1
	38	04-1057	1	Coupler	.5
	39	02-10016	1	Bolt	.5
	40	02-1201	1	Nut	.1
	41	03-10155	4	Bushing (Optional)	.5
	42	04-10320	4	Ball Valve (Optional)	4
	43	03-10091	4	Hose Barb (Optional)	2
	44	06-10185	4	Tubing (Optional)	4
	45	01-9026S	2	Hanger Plate (Optional)	3
	46	02-12014	6	Hex Nuts (Optional)	.5
	47	01-9172S	4	Tubing Hangers (Optional)	2.5
	48	02-100115	6	Bolt (Optional)	1
	49	03-101005	4	Hose Clamp (Optional)	.5

ASSEMBLY NO. 08-0001U
VACUUM SYSTEM ASSEMBLY

Sub Assy.	Item	Part No.	Quantity	Description	Wt. #
08-1000				Drain Stop Assembly	
	1	07-1000	1	Drain Stop Arm	3.5
	2	04-1000	1	Gasket	1.5
	3	02-10016	1	Bolt	.1
	4	02-10002	1	Bolt	.1
	5	02-1100	1	Flatwasher	.1
	6A	02-1201	1	Nut	.1
	6B	02-1200	1	Nut	.1
08-1001				Overflow Stop Assembly	
	7	07-1109	1	Float Sub. Assembly	4
	8	04-1001	1	Gasket	.1
	9	02-10003	1	Bolt	.1
	10	02-1200	1	Nut	.1
	11	02-1100	1	Flatwasher	.1
08-10022				Cover Assembly	
	12	07-1002	1	Lid	5
	13	06-1022	1	Gasket	2.7
08-1003				Nortech Vacuum Head Assy.	
	14	04-1004	1	Exhaust Housing	9.5
	15	04-1005	1	Exhaust Silencer	4.7
	16	04-1006	1	Venturi	2.2
	17	04-1007	1	Air Jet	2.7
	18	04-1008	1	Venturi Box	2.7
	19	04-1032	1	Valve	5.8
	20	04-1056	1	Coupler	1.7
	21	04-1010	1	Gasket	.1
	22	02-10010	3	Bolt	.1

CONFIDENTIAL-PROPRIETARY INFORMATION
 REPRODUCTION OF THESE DRAWINGS OR THE
 MANUFACTURING OF PRODUCTS FROM THESE
 DRAWINGS FOR USE BY ANYONE OTHER THAN
 SPOKANE INDUSTRIES INC. OF SPOKANE, WA
 IS STRICTLY PROHIBITED WITHOUT WRITTEN
 CONSENT

SECTION 5.6.1

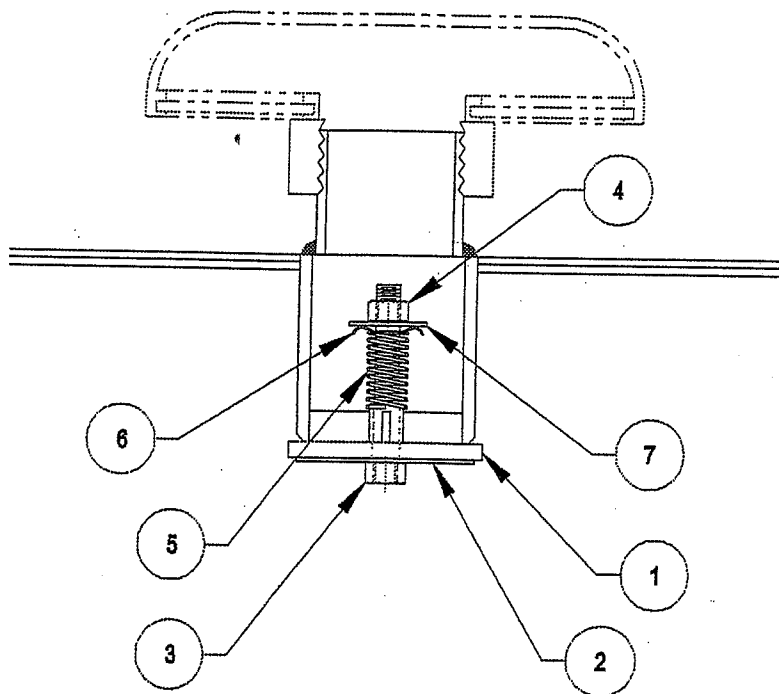

ASSEMBLY No. SMP15575GOV
 MAJOR ASSEMBLY- VACUUM GOVERNOR
 SECTION 5.6.1

Sub Assy.	Item	Part No.	Quantity	Description	Wt. #'s
SMP15575GOV			1	Vacuum Governor Assembly	
	1	15575GOV-1	1	Gasket	.3
	2	01-903S	1	Washer, Flat	.1
	3	02-10013	1	Bolt	.2
	4	02-12014	1	Nut	.1
	5	15575GOV-5	1	Spring, Century J-38	.1
	6	15575GOV-6	1	Washer, Cup 92922A036	.1
	7	15575GOV-7	1	Washer, Flat 91090A121	.1

CONFIDENTIAL-PROPRIETARY INFORMATION
REPRODUCTION OF THESE DRAWINGS OR THE MANUFACTURING
OF PRODUCTS FROM THESE DRAWINGS FOR USE BY ANYONE
OTHER THAN SPOKANE METAL PRODUCTS OF SPOKANE, WA
IS STRICTLY PROHIBITED WITHOUT WRITTEN CONSENT.

SECTION 5.7

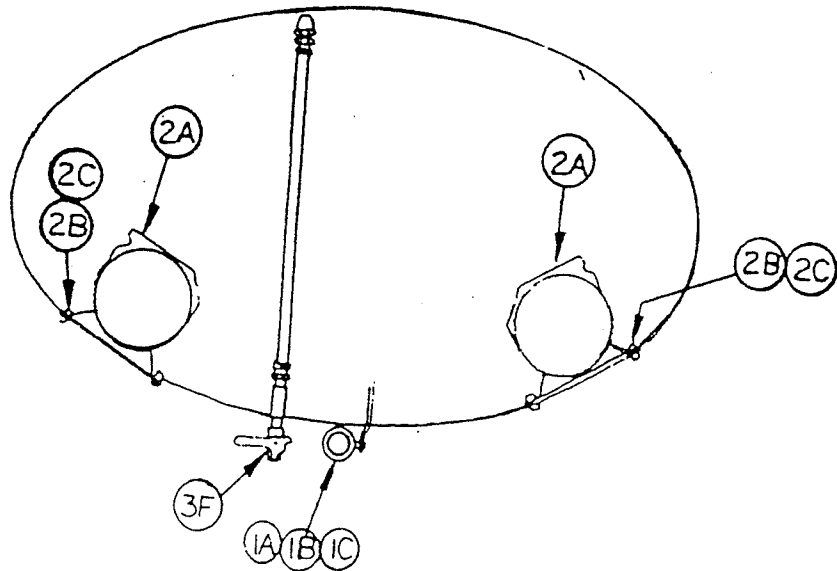
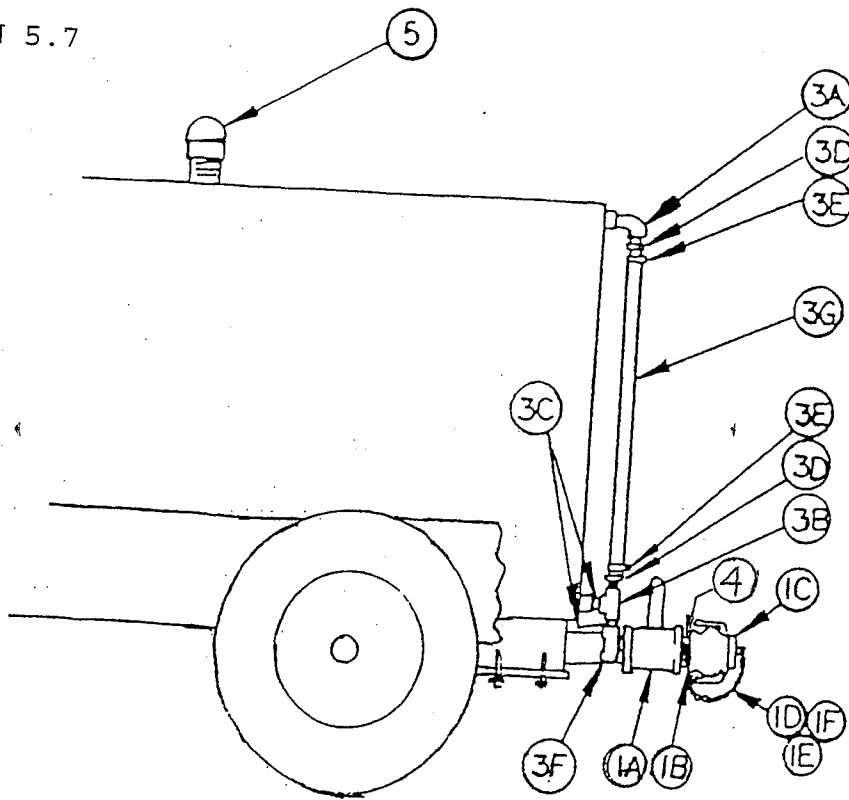

REAR VIEW

MAJOR ASSEMBLY - MISC. FIXTURES

Sub Assy.	Item	Part No.	Quantity	Description	Wt.#
08-1012				Drain Assembly	
	1A	04-10321	1	Ball Valve	6
	1B	04-1033	1	Camlock Adaptor	1.5
	1C	04-10331	1	Camlock Plug	.5
	1D	04-1034	1	Safety Chain	.2
	1E	04-1034	1	S-Hook, Safety Link	.1
	1F	04-1035	1	S-Hook, Safety Link	.1
08-1013				Grounding Reel Assembly	
	2	04-10361	1	Grounding Reel	12
	2A	04-1036	1	Grounding Reel	12
	2B	02-10040	4	Bolts	.3
	2C	02-12041	4	Nuts	.1
08-1014	3			Sight Gauge Assembly	
	3A	03-0017S	2	Elbow	.5
	3B	03-1007	1	Tee	.5
	3C	03-1008	2	Nipple	.5
	3D	03-11130	2	Hose Barb	1
	3E	03-1010	2	Hose Clamp	.1
	3F	04-1032	1	Ball Valve	2.7
	3G	06-2527	1	Tubing	.1
	4	04-10393	1	Drain Screen	.1
	5	04-1037	1	Vent	3

SECTION 5.8

MAJOR ASSEMBLY - REMOTE DRAIN FUNNEL

ASSEMBLY 07-1110U

Sub Assy.	Item	Part No.	Quantity	Description	Wt.#
07-11103				REMOTE DRAIN FUNNEL, BASE	17
	1	07-1100	1	BASE SECTION FAB S/S	
	2	05-10012	1	CLAMP, BASE	
	3	02-10181	1	SCREW, CLAMP	
	4	05-0037	1	PLASTIC	
07-11104				REMOTE DRAIN FUNNEL, LOWER	2.5
	7	01-92452	1	TUBE, 3" O.D.	
	8	05-10022	1	BASE CLAMP	
	9	02-10181	1	SCREW, CLAMP	
	10	05-0037	1	PLASTIC	
07-11105				REMOTE DRAIN FUNNEL, UPPER	1.75
	12	01-9242	1	TUBE, 2-1/2" O.D.	
	13	05-10032	1	CLAMP, BASE	
	14	02-10015	1	SCREW, CLAMP	
	15	05-0037	1	PLASTIC	
07-11106				REMOTE DRAIN FUNNEL, TOP, FAB	13
	17	01-8250	1	FUNNEL, CAST ALUM	
	18	04-1039	1	DEBRIS SCREEN	
	19	02-1200	1	LOCK NUT	
	20	06-1022	1	NITRILE GASKET	

SECTION 5.8 (CONTINUED)

MAJOR ASSEMBLY - REMOTE DRAIN FUNNEL

ASSEMBLY 07-1110U

07-11107		07-1116		REMOTE FUNNEL LID ASSY	12
	21	01-9007	1	LID FABRICATION	
	22	01-91984S	1	ROD, THREADED	
	23	02-1200	2	LOCK NUTS	
	24	01-9233S	1	PIPE	

WARRANTY

SPOKANE INDUSTRIES, INC.

SPOKANE METAL PRODUCTS DIVISION

Spokane Washington

400 GALLON VACUUM FUEL BOWSER

ONE YEAR LIMITED WARRANTY

Seller warrants its "400 Gallon Bowser" to be free from defects in material and workmanship under the normal use and service for which the unit is intended if, but only if the unit has been properly operated, maintained and stored in accordance with printed directions contained in the product manual. Our obligation under this warranty shall be limited to the repair or exchange of equipment and parts which may prove defective within one year of the date the unit is put into service but shall in no event extend beyond a date two years from the date the unit is shipped from our plant. All transportation charges on parts returned to us for replacement under this warranty must be returned pre-paid.

This warranty does not extend to damages caused by environmental factors varying from normal design conditions, whether natural or man-made, or to units subjected to misuse, negligence or accident. This warranty likewise does not extend to the unit or any parts thereof which have been repaired or altered improperly or in any way so as to effect adversely its stability or reliability. This warranty does not cover parts or labor required to repair or replace parts whose usefulness is exhausted due to normal operation of this unit.

THIS WARRANTY IS EXPRESSLY IN LIEU OF ALL OTHER WARRANTIES, EXPRESS OR IMPLIED, INCLUDING ANY IMPLIED WARRANTY OF MERCHANTABILITY OR FITNESS FOR A PARTICULAR PURPOSE NOT SET FORTH IN A WRITING SIGNED BY AN AUTHORIZED REPRESENTATIVE OR SELLER. SELLER SHALL IN NO EVENT BE LIABLE FOR ANY CONSEQUENTIAL LOSS OR DAMAGE RESULTING FROM THE USE OR LOSS OF USE OF THIS UNIT.