

---

**TECHNICAL MANUAL**

**OPERATION AND  
MAINTENANCE INSTRUCTIONS  
WITH  
ILLUSTRATED PARTS BREAKDOWN**

**HANDIFUELER™**  
Ground Support Service Cart

**Model No. AGE400S-12VDC  
Model No. AGE600S-12VDC**



SPOKANE INDUSTRIES, INC.  
METAL PRODUCTS DIVISION  
3808 N. SULLIVAN RD, BLDG #4  
SPOKANE VALLEY, WA 99216  
USA

[WWW.SPOKANEINDUSTRIES.COM](http://WWW.SPOKANEINDUSTRIES.COM)  
[WWW.HANDIFUELER.COM](http://WWW.HANDIFUELER.COM)

---

**NOVEMBER 2009, VERSION 1.0**

# LIST OF EFFECTIVE PAGES

INSERT LATEST CHANGED PAGES. DESTROY SUPERSEDED PAGES.

**NOTE:** The portion of the text affected by the changes is indicated by a vertical line in the margins of the page. Changes to illustrations are indicated by miniature pointing hands. Changes to wiring diagrams are indicated by miniature pointing hands or by shaded areas. A vertical line running the length of a figure in the outer margin of the page indicates that the figure is being added.

Dates of issue for original and changed pages are:  
 Original ..... 0 .....01 Nov 2009

TOTAL NUMBER OF PAGES IN THIS PUBLICATION IS 70, CONSISTING OF THE FOLLOWING:

Page No.	*Change No.	Page No.	*Change No.	Page No.	*Change No.
Title .....	0				
A .....	0				
i-v .....	0				
vi Blank .....	0				
vii .....	0				
viii Blank .....	0				
ix - x .....	0				
1-1 - 1-5 .....	0				
1-6 Blank .....	0				
2-1 .....	0				
2-2 Blank .....	0				
3-1 .....	0				
3-2 Blank .....	0				
4-1 - 4-7 .....	0				
4-8 Blank .....	0				
5-1 - 5-16 .....	0				
6-1 - 6-2 .....	0				
7-1 - 7-23 .....	0				
7-24 Blank .....	0				

\*Zero in this column indicates an original page.

# Limited Warranty Agreement Aviation Fuel Products

Spokane Industries of Spokane, Washington (SI) hereby Warrants to the purchaser (the Warrantee) that all products explicitly covered by this Warranty Agreement have been thoroughly inspected upon completion and that they and their component parts are free of defects in materials and workmanship. SI further warrants that in the event the product fails due to defects in materials and/or workmanship within a period of sixty (60) months from the effective date of this warranty that SI will provide replacement parts free of charge except for those components which are covered by an Original Equipment Manufacturer's (OEM) Warranty, in which case coverage will be provided by that OEM.

## Coverage

The SI Fuel Products Limited Warranty Agreement covers all products manufactured for use as Ground Support, Fueling and Defueling equipment. Certain components of these products are manufactured by third party Original Equipment Manufacturers (OEMs) and are covered by these manufacturers' Warranties.

SI Warranty coverage is contingent upon proper installation, operation, maintenance and repair of the product. Refer to the appropriate manuals and documentation for assistance. In cases of uncertainty, SI must be consulted prior to any service work being performed. Failure to do so may result in the termination of Warranty coverage.

## Terms and Conditions

### REQUESTS FOR WARRANTY COVERAGE

Requests for Warranty Coverage should be addressed to the SI, Spokane Metal Products Customer Support and Service Department. Please provide the Model Number, Ship Date, Original Purchaser, and Point of Installation, and, if possible, our original Sales Order number. The Service Department will make a Warranty determination based upon this information and our internal records. If Warranty coverage is in effect replacement parts will be sent provided that credit terms have been established. If Warranty coverage is not in effect, the cost of replacement parts will be quoted.

### TRANSFERABILITY

This warranty is extended only to the original purchaser named on this warranty certificate and is not transferable without the express written consent of SI. Transferability is contingent on the product being in warrantable condition. SI reserves the right to verify product warrantability by whatever means is deemed appropriate, and the right to refuse to transfer the warranty with or without cause. Warranty transfer requests must be made in advance of the sale or transfer of the product. SI accepts no responsibility for any costs associated with the transfer of existing warranties including any costs associated with verification of product warrantability. Requests for Warranty transfers should be addressed c/o SI, Spokane Metal Products Customer Support and Service Department.

### RETURN OF WARRANTY PARTS ("EXCHANGE")

- For the purposes of quality assurance, SI requires that certain parts and assemblies covered under the SI Limited Warranty Agreement be returned by the Warrantee upon receipt of replacements (known as "Exchange"). In these cases, SI will authorize the shipment of replacement parts immediately and provide a Returned Merchandise Authorization (RMA) number along with a full retail invoice for the replacement parts pending receipt of the Warranty ("defective") parts. The Warranty parts must be returned to SI within 30 days with the RMA number CLEARLY marked on the shipping materials. At this time SI will inspect the Warranty parts to verify Warranty coverage. If the Warranty parts are deemed defective due to materials and workmanship SI will issue a full credit for the replacement parts. If the Warranty parts are not returned within thirty days the Warrantee's account will not be credited. Payment in full is then due and subject to the standard terms and conditions of SI credit.
- In cases where returned parts are deemed **not to be defective**, SI reserves the right to **refuse to cancel the applicable invoice**.
- Exchange parts must be properly packed and sealed and shipped to SI by prepaid freight. Under no circumstances does SI accept C.O.D. shipments.
- SI Warranty replacement parts are provided subject to the terms and conditions of the SI Sales and Service Agreement which states that where no other Warranty coverage is in place, Service and Warranty parts are covered by a ninety day limited Warranty.

## LIMITATIONS

The following limitations apply to the SI Limited Warranty Agreement:

- SI shall not be liable under any circumstances for any incidental or consequential damages including, but not limited to, loss of time, inconvenience, expenses incurred by purchaser in order to remedy defects, or liability purchaser may have with respect to any other person for loss or damage arising from the operation of the product or the product's failure to operate in any way, or any other type of consequential damage or economic loss.
- This warranty is limited to defects in materials and workmanship. SI assumes no liability whatsoever for damages arising from the inability of the product to perform a certain task. Damage arising during shipping and handling, improper installation, use, maintenance, repair, or any unauthorized modifications, whether performed by qualified service personnel or not, neglect, Acts of God, etc., are expressly excluded. **In any case, SI's liability shall be limited only to the provision of suitable replacement parts for those which failed due to defects in materials and workmanship. Incidental damage resulting from the failure, and labor costs associated with the repair and/or replacement of the product, its assemblies, and component parts, are excluded.**
- SI reserves the right to limit or terminate warranty coverage in instances where repeated product failures are a result of failure to correct operating conditions which are in any way abnormal or exceed operating condition specifications. It is the purchaser's responsibility to remedy such conditions as may be likely to cause initial and/or repeated failures of the equipment. SI assumes no responsibility whatsoever for any costs incurred for this purpose.
- The SI Limited Warranty Agreement covers only replacement parts supplied by SI. SI makes every reasonable effort to ensure an adequate supply of replacement parts. However, in cases where the exact replacement part is no longer available, SI reserves the right to provide a suitable substitute.
- Components such as batteries, which are subject to normal wear and tear are pro-rated under the provisions of this Warranty. Warranty coverage shall be pro-rated according to the amount of Warranty coverage remaining.

## EXCLUSIONS

The following exclusions apply to the SI Limited Warranty Agreement:

- The SI Limited Warranty Agreement applies only to authentic new and, where applicable, refurbished products. Products sold "As Is", demonstration units, and any other products subjected to previous use are explicitly excluded.
- The SI Limited Warranty Agreement excludes any and all parts and assemblies which are covered by another manufacturer's Warranty (see above).
- This Limited Warranty Agreement constitutes the complete and entire SI Warranty statement. Any items and/or circumstances not expressly covered by this Warranty Agreement are hereby excluded. This includes, but is not limited to, such additional offerings as SI may make available from time to time. These offerings are independent of this Agreement and, as such, do not in any way extend, modify, or otherwise alter the coverage, terms, conditions, limitations, and exclusions as they are set forth here unless **explicitly stated**.
- The failure to observe any and all of the terms and conditions of this warranty will render it null and void.
- Although all reasonable precautions are taken to ensure that shipping damage is avoided, any damage incurred during the shipment and installation of the product is explicitly excluded. Any and all damage during shipment is the sole responsibility of the transportation carrier(s). Product should be thoroughly inspected prior to acceptance from the freight carrier. All SI products are shipped F.O.B. Spokane Washington.
- This Warranty is in lieu of all other warranties whatsoever, express, implied and statutory, including, without limitation, the implied warranties of merchantability and fitness for a particular purpose, and all such warranties express or implied, shall be excluded from this transaction and shall not apply to the goods sold. Product should be thoroughly inspected prior to acceptance from the freight carrier. All SI products are shipped F.O.B. Spokane Washington.

Warranty inquiries are welcome and should be addressed to:

SI Service Department  
Spokane Industries  
Spokane Industrial Park Building 4  
N3808 Sullivan Rd.  
Spokane, Washington 99216  
(800) 541-3601

# TABLE OF CONTENTS

Chapter	Page	Chapter	Page
LIMITED WARRANTY .....	i	4.5.1	Parking Brake .....
LIST OF ILLUSTRATIONS .....	v	4.5.2	Static Bonding/Grounding .....
LIST OF TABLES .....	v	4.5.3	Liquid Level Gauge .....
FOREWARD .....	vii	4.5.4	Low-point Drain .....
SAFETY SUMMARY .....	ix	4.5.5	Filling the HANDIFUELER .....
1 INTRODUCTION AND GENERAL		4.5.6	Work Lights .....
INFORMATION .....	1-1	4.5.7	Battery Charging .....
1.1 Introduction .....	1-1	4.5.7.1	On-board Battery Charging .....
1.2 Purpose .....	1-1	4.5.7.2	Tow Vehicle Charging .....
1.3 Description .....	1-1	4.6	Fuel Service Methods .....
1.3.1 Major Components and Operational		4.6.1	Fueling .....
Features .....	1-1	4.6.2	Fuel Extraction Method .....
1.3.2 Fueling Method .....	1-1	4.7	Non-Fuel Related Functions .....
1.3.3 Fuel Extraction Method .....	1-1	4.7.1.1	Air Tank Filling .....
1.3.4 Compressed Air .....	1-1	4.7.1.2	AGE Tire Service .....
1.3.5 Fluid Stowage .....	1-1	4.8	Supplemental Operations .....
1.3.6 Spill Containment .....	1-1	4.8.1	Towing the HANDIFUELER .....
1.3.7 Cabinet Lighting .....	1-1	4.8.2	Parking the HANDIFUELER .....
2 SPECIAL TOOLS AND TEST EQUIPMENT .....	2-1	4.8.3	Draining the HANDIFUELER .....
2.1 General .....	2-1	5	5 MAINTENANCE INSTRUCTIONS .....
2.2 Electrical Test Equipment .....	2-1	5.1	Operational Checkout .....
3 PREPARATION FOR USE AND SHIPMENT .....	3-1	5.2	Inspection and Preventive Maintenance .....
3.1 Preparation for Use .....	3-1	5.2.1	Inspection .....
3.2 First Time use .....	3-1	5.2.2	Preventive Maintenance .....
3.2.1 Un-packaging .....	3-1	5.3	Repair and Replace Instructions .....
3.2.2 Taking Inventory .....	3-1	5.3.1	General Tank Equipment .....
3.3 Shipment .....	3-1	5.3.2	Manway Assembly .....
3.3.1 Preparation for Shipment .....	3-1	5.3.2.1	Disassembly/Reassembly Steps .....
3.3.2 Truck Shipment .....	3-1	5.3.2.2	Adjustment .....
3.3.3 Air Shipment .....	3-1	5.3.3	Front Undercarriage Assembly .....
4 OPERATION INSTRUCTIONS .....	4-1	5.3.3.1	Wheel Assembly Removal .....
4.1 Introduction .....	4-1	5.3.3.2	Front Hub Assembly .....
4.2 General Precautions .....	4-1	5.3.3.3	Spindle Assembly .....
4.3 Controls and Indicators .....	4-1	5.3.3.4	Tow Latch Assembly .....
4.4 Operation .....	4-1	5.3.3.5	Steering Arm Assembly .....
4.5 Supporting Operations .....	4-2	5.3.3.6	Tie Rod Assembly .....
		5.3.3.7	Front Undercarriage Assembly
			Removal .....
		5.3.4	Rear Undercarriage Removal .....
		5.3.4.1	Rear Wheel Assembly Removal .....
		5.3.4.2	Rear Hub/Brake Drum Assembly .....
		5.3.4.3	Parking Brake Assembly .....
		5.3.4.3.1	Brake Handle and Cable Assembly .....
		5.3.4.3.2	Mechanical Brake Assembly .....
		5.3.4.3.3	Parking Brake Adjustment .....
		5.3.4.4	Rear Spindle .....

## TABLE OF CONTENTS - CONTINUED

Chapter	Page	Chapter	Page
5.3.4.5	Rear Undercarriage Assembly	7.1	Introduction..... 7-1
	Removal ..... 5-8	7.2	Models Covered..... 7-1
5.3.5	Wheel Assembly ..... 5-9	7.3	Maintenance Parts List (MPL)..... 7-1
5.3.6	Plumbing Assembly ..... 5-10	7.3.1	Figure and Index Number Column ..... 7-1
5.3.6.1	Fuel Pump ..... 5-10	7.3.2	Part Number Column ..... 7-1
5.3.6.2	Fuel Meter..... 5-10	7.3.3	Commercial and Government Entity (CAGE) Code Column..... 7-1
5.3.6.3	Filter Housing ..... 5-10	7.3.4	Description Column ..... 7-1
5.3.6.4	Selection Valve ..... 5-10	7.3.5	Units Per Assembly Column..... 7-2
5.3.6.5	Hose Reel..... 5-10	7.3.6	Usable On Code Column ..... 7-2
5.3.6.6	Other Plumbing Assembly Items ..... 5-10	7.3.7	Source, Maintenance and Recover- bility (SMR) Code Column..... 7-2
5.3.6.6.1	Pressure Relief Valve..... 5-12	7.3.8	Symbols Used in the MPL ..... 7-2
5.3.6.6.2	Y-Strainer..... 5-12	7.3.9	Multi-sheet Illustrations ..... 7-2
5.3.6.6.3	Hard and Soft Plumbing Lines ..... 5-12	7.4	Numerical Index ..... 7-2
5.3.6.7	Fuel Filter Element..... 5-12	7.4.1	Part Number Column ..... 7-2
5.3.7	Electrical System..... 5-12	7.4.2	Figure and Index Column ..... 7-2
5.3.7.1	Main Electrical Panel..... 5-12	7.5	Reference Designation Index (RDI) ..... 7-2
5.3.7.2	Operator Console ..... 5-12	7.6	Usable On Codes ..... 7-2
5.3.7.3	Charging System..... 5-13	7.7	Source, Maintenance and Recover- bility (SMR) Codes and Unique Source Codes ..... 7-3
5.3.7.3.1	On-board Battery Charger..... 5-13	7.8	Commercial and Government Entity (CAGE)..... 7-3
5.3.7.3.2	Tow Vehicle Charging ..... 5-13	7.9	Parts Standardization ..... 7-4
5.4	Troubleshooting ..... 5-13	7.10	List of Manufacturer's Codes (CAGE)..... 7-4
5.5	Preventive Maintenance ..... 5-13		
6	DIAGRAMS..... 6-1		
7	ILLUSTRATED PARTS BREAKDOWN..... 7-1		
SECTION I	FOREWORD ..... 7-1	SECTION II	MAINTENANCE PARTS LIST ..... 7-6

## LIST OF ILLUSTRATIONS

Figure	Title	Page	Figure	Title	Page
1-1	Component Identification .....	1-2	5-10	Wheel Assembly .....	5-8
1-2	Component Identification Continued .....	1-3	5-11	Brake Handle and Cable Assembly .....	5-9
4-1	Parking Brake Handle .....	4-2	5-12	Plumbing Assembly .....	5-12
4-2	Battery and Flood Light Switches .....	4-3	5-13	Fuel Filter .....	5-12
4-3	Operator Console .....	4-3	6-1	Wiring Schematic .....	6-1
4-4	Main Electrical Panel .....	4-4	6-2	Wiring Schematic Continued .....	6-2
4-5	Pneumatic Air Tank .....	4-6	7-1	Overall Assembly .....	7-6
4-6	Releasing the Tow Bar .....	4-7	7-2	Pump Module .....	7-8
4-7	Drain Points .....	4-7	7-3	Pneumatic Assembly .....	7-10
5-1	Manway Assembly .....	5-2	7-4	Manway Assembly .....	7-11
5-2	Generic Undercarriage Lift Points .....	5-2	7-5	Front Undercarriage Assembly .....	7-12
5-3	Front Hub Assembly .....	5-3	7-6	Rear Undercarriage Assembly .....	7-14
5-4	Tow Bar Removal .....	5-4	7-7	Wheel Assembly .....	7-15
5-5	Removal of Front Undercarriage .....	5-4	7-8	Front Hub Assembly .....	7-16
5-6	Front Undercarriage Exploded Assembly .....	5-5	7-9	Rear Hub Assembly .....	7-17
5-7	Rear Undercarriage .....	5-6	7-10	Plumbing System .....	7-18
5-8	Rear Hub and Brake Drum .....	5-7	7-11	Main Electrical Panel .....	7-20
5-9	Mechanical Parking Brake .....	5-8	7-12	Operator Console .....	7-22

## LIST OF TABLES

Table	Title	Page	Table	Title	Page
1-1	Leading Particulars for Model Number AGE400S-12VDC .....	1-4	5-4	Troubleshooting - Rear Undercarriage And Brakes .....	5-14
1-2	Leading Particulars for Model Number AGE600S-12VDC .....	1-5	5-5	Troubleshooting - Plumbing System .....	5-14
3-1	Component Inventory .....	3-1	5-6	Troubleshooting .....	5-15
4-1	Controls and Indicators .....	4-1	5-7	Preventive Maintenance .....	5-15
5-1	Troubleshooting - General Tank .....	5-13	5-8	Daily Pre-Operation Inspection Check Sheet .....	5-16
5-2	Troubleshooting - Manway Assembly .....	5-13			
5-3	Troubleshooting - Front Undercarriage .....	5-14			



# FOREWORD

## 1. GENERAL.

## 2. PURPOSE AND SCOPE.

This manual provides operation and maintenance instructions for the HANDFUELER™ Ground Support Service Cart.

## 3. ARRANGEMENT.

This manual consists of seven chapters. Chapter 1 contains introductory material for the manual and general description information. Chapter 2 contains a list of special tools and test equipment. Chapter 3 provides instructions and references for preparation for use, reshipment, air transportability, and storage. Chapter 4 provides operating instructions. Chapter 5 provides maintenance instructions with schematics. Chapter 6 contains electrical schematics. Chapter 7 contains Illustrated Parts Breakdowns and Maintenance Parts Lists.

## 4. RELATED PUBLICATIONS.

### List of Related Publications

Number	Title
AFI 23-502	Recoverable and Unusable Liquid Petroleum Products
TO 42B-1-23	Management of Recoverable and Waste Liquid Petroleum Products
TO 00-25-172	Ground Servicing of Aircraft and Static Grounding/Bonding

## 5. ABBREVIATIONS AND SYMBOLS.

FOD	Foreign Object Damage/Debris
NPT	National Pipe Thread



# SAFETY SUMMARY

## 1. GENERAL SAFETY INSTRUCTIONS.

This manual describes physical and chemical processes which may cause injury or death to personnel, or damage to equipment if not properly followed. This safety summary includes general safety precautions and instructions that must be understood and applied during operation and maintenance to ensure personnel safety and protection of equipment. Prior to performing any task, the WARNINGS, CAUTIONS and NOTES included in that task shall be reviewed and understood.

## 2. WARNINGS, CAUTIONS AND NOTES.

WARNINGS and CAUTIONS are used in this manual to highlight operating or maintenance procedures, practices, conditions or statements which are considered essential to protection of personnel (WARNING) or equipment (CAUTION). WARNINGS and CAUTIONS immediately precede the step or procedure to which they apply. WARNINGS and CAUTIONS consist of four parts: heading (WARNING or CAUTION), a statement of the hazard, minimum precautions, and possible result if disregarded. NOTES are used in this manual to highlight operating or maintenance procedures, practices, conditions or statements which are not essential to protection of personnel or equipment. NOTES may precede or follow the step or procedure, depending upon the information to be highlighted. The headings used and their definitions are as follows:

### **WARNING**

Highlights an essential operating or maintenance procedure, practice, condition, statement, etc, which if not strictly observed, could result in injury to, or death of, personnel or long term health hazards.

### **CAUTION**

Highlights an essential operating or maintenance procedure, practice, condition, statement, etc, which if not strictly observed, could result in damage to, or destruction of, equipment or loss of mission effectiveness.

## **NOTE**

Highlights an essential operating or maintenance procedure, condition, or statement.

## 3. PROTECTIVE CLOTHING.

When fuels are being handled, approved equipment such as gloves, eye protection, face shields, etc. shall be used. Local standard operating procedures and AFOSH (Air Force Occupation Safety and Health) standards, will always take precedence over this publication.

## 4. STATIC BONDING AND GROUNDING.

Improper static bonding and grounding can lead to a fire. Refer to TO 00-25-172, Ground Servicing of Aircraft and Static Grounding/Bonding, for specific Air Force procedures.

## 5. FIRE HAZARD.

This equipment is designed to safely handle fuel. However, fuel is inherently dangerous and no amount of engineering can assure that a fire will not occur. Always assume a fire can occur. Read and understand this publication.

## 6. CONFINED SPACE.

The equipment described in this manual is considered to be a confined space.

## 7. LOCKOUT / TAGOUT.

Personnel shall be aware of the hazards associated with unguarded machinery parts, capacitors, gaseous and wet pipe systems, spring loaded devices, etc. Lockout/tagout the energy source prior to performing maintenance, adjustment, or other procedures that would bypass safety guards, barriers, or otherwise expose personnel to hazardous energy sources. Any equipment, machine, or process that could unexpectedly energize, start-up, or release energy will be equipped with a means to lockout/tagout the energy source(s).

]

## 8. AREA OF USE.

This equipment has been designed to operate outdoors. Flammable and/or combustible vapors in ignitable quantities could be produced under certain circumstances. Additionally, local protocols must be consulted to determine if fuel draining equipment can be used in the location being considered.

## 9. EQUIPMENT SECURITY.

This equipment has lockable features to prevent unauthorized use. The manway assembly and the fill/vent port have been designed to accept a standard padlock.

# CHAPTER 1

## INTRODUCTION AND GENERAL INFORMATION

### 1.1 INTRODUCTION.

The instructions in this manual cover the operation and maintenance of the HANDIFUELER Ground Support Service Cart. These instructions are intended to serve as “recommended practices” only and are not intended to replace local policies, procedures, or work instructions.

### 1.2 PURPOSE.

The HANDIFUELER Ground Support Service Cart provides a convenient, safe, and efficient means to fuel Aircraft Ground Equipment (AGE) and to extract fuels from AGE. HANDIFUELER is a trademark of Spokane Industries, Inc.

### 1.3 DESCRIPTION.

Refer to Figures 1-1 and 1-2 for location and identification of major components and Tables 1.1 and 1.2 for leading particulars of each size of unit.

#### 1.3.1 Major Components and Operational Features.

The HANDIFUELER consists of a inner tank assembly and an outer tank, (known as double wall construction.) Fuel servicing is accomplished with a 12-volt DC pump, fuel meter, fuel filter, and a plumbing system that allows for the direction of fuel into or out-of the inner tank assembly based on the method of fuel service selected. The HANDIFUELER is also designed to allow for non-fuel related serving of AGE such as adding compressed air to pneumatic tires and topping of critical fluids such as anti-freeze, oil, hydraulic fluid, or what ever the end user decides to carry on the HANDIFUELER.

1.3.2 Fueling Method. The Fueling Method is used to fuel AGE wherever it is located. Fuel is metered and filtered through the plumbing system much like a conventional gas pump. A 35-foot fuel hose is used to make Fueling safe and convenient. An auto-shutoff nozzle is connected to the fuel hose to allow the user to safely perform other AGE service tasks within the proximity of the piece of equipment being serviced.

1.3.3 Fuel Extraction Method. The Fuel Extraction Method is used to extract fuel from AGE whenever a maintenance or deployment requirement is presented. Fuel is filtered through the plumbing system and placed back in the tank. A 35-foot fuel hose is used to make Fuel Extraction safe and convenient. Two different extraction wands (one rigid and one soft) can be connected to the fuel hose to allow the user to access different sizes and shapes of AGE fuel tanks.

1.3.4 Compressed Air. The HANDIFUELER is equipped with a 125-psi 10-gallon air receiver, 25-foot long hose reel, and a standard air chuck with gauge. Pneumatic tires on AGE can be conveniently brought back to proper inflation pressure wherever it is located.

1.3.5 Fluid Stowage. The HANDIFUELER is equipped with an easy-to-access stowage bin for three 5-liter user supplied fluid containers.

1.3.6 Spill Containment. A 10-gallon spill containment kit is provided for early and fast containment of fuel spill should the need arise.

1.3.7 Cabinet Lighting. Cabinet lighting is provided for night-time fuel servicing

### **WARNING**

Read the manual in its entirety before operating, shipping, or performing maintenance procedures. Flammable and combustible vapors can cause fire and/or explosion and lead to serious injury or death.

### **CAUTION**

Read the manual in its entirety before operating, shipping, or performing maintenance procedures. Flammable and combustible vapors can cause fire and/or explosion and lead to serious equipment and aircraft damage.

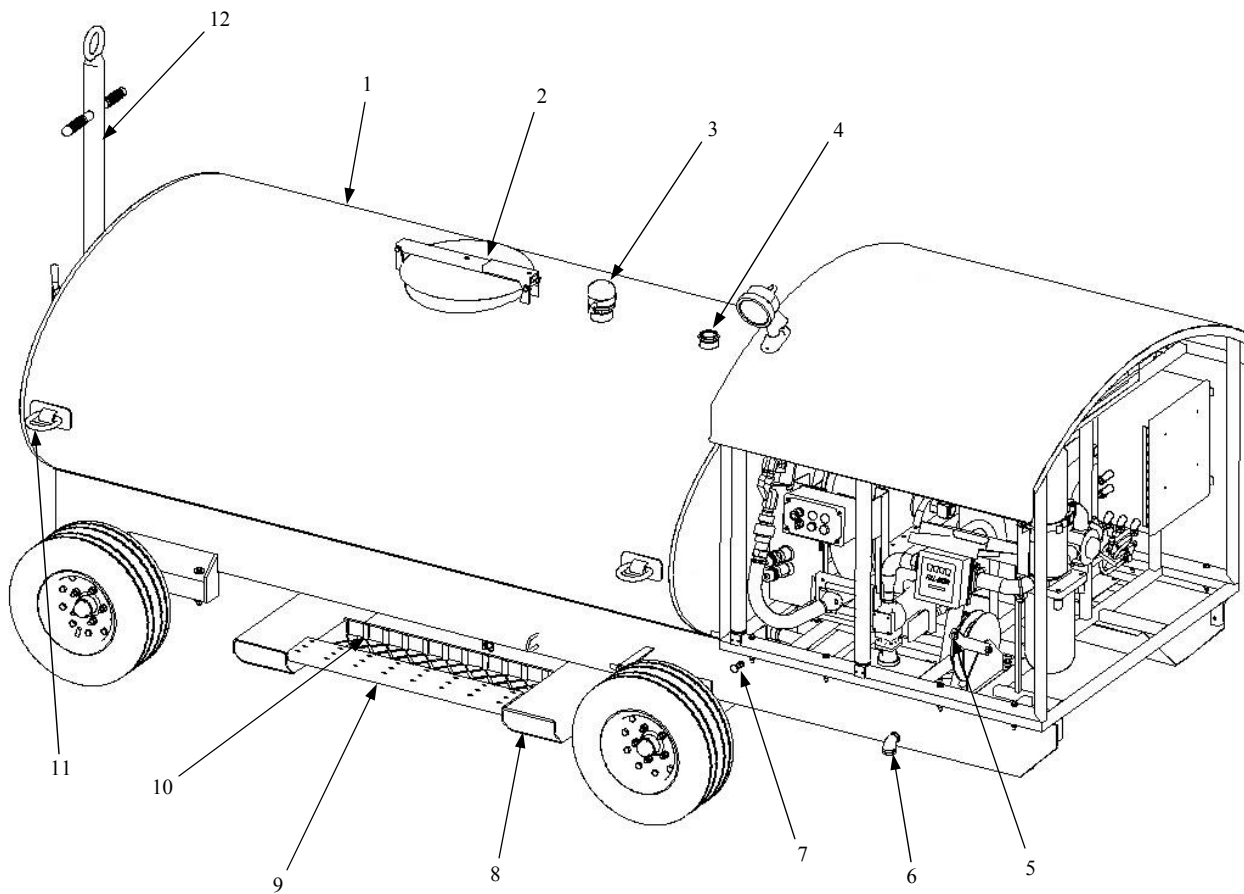

- |                            |                             |
|----------------------------|-----------------------------|
| 1. TANK                    | 7. LOW-POINT DRAIN CABLE    |
| 2. LOCKABLE MANWAY         | 8. 4 X 8 FORK POCKETS       |
| 3. LOCKABLE FILL/VENT PORT | 9. STEP/WORK PLATFORM       |
| 4. LIQUID LEVEL GAUGE      | 10. CHOCK STOWAGE           |
| 5. GROUND/BOND REEL        | 11. TIE DOWN D-RINGS        |
| 6. LOW-POINT DRAIN SPOUT   | 12. STEERABLE UNDERCARRIAGE |

**Figure 1-1. Component Identification**

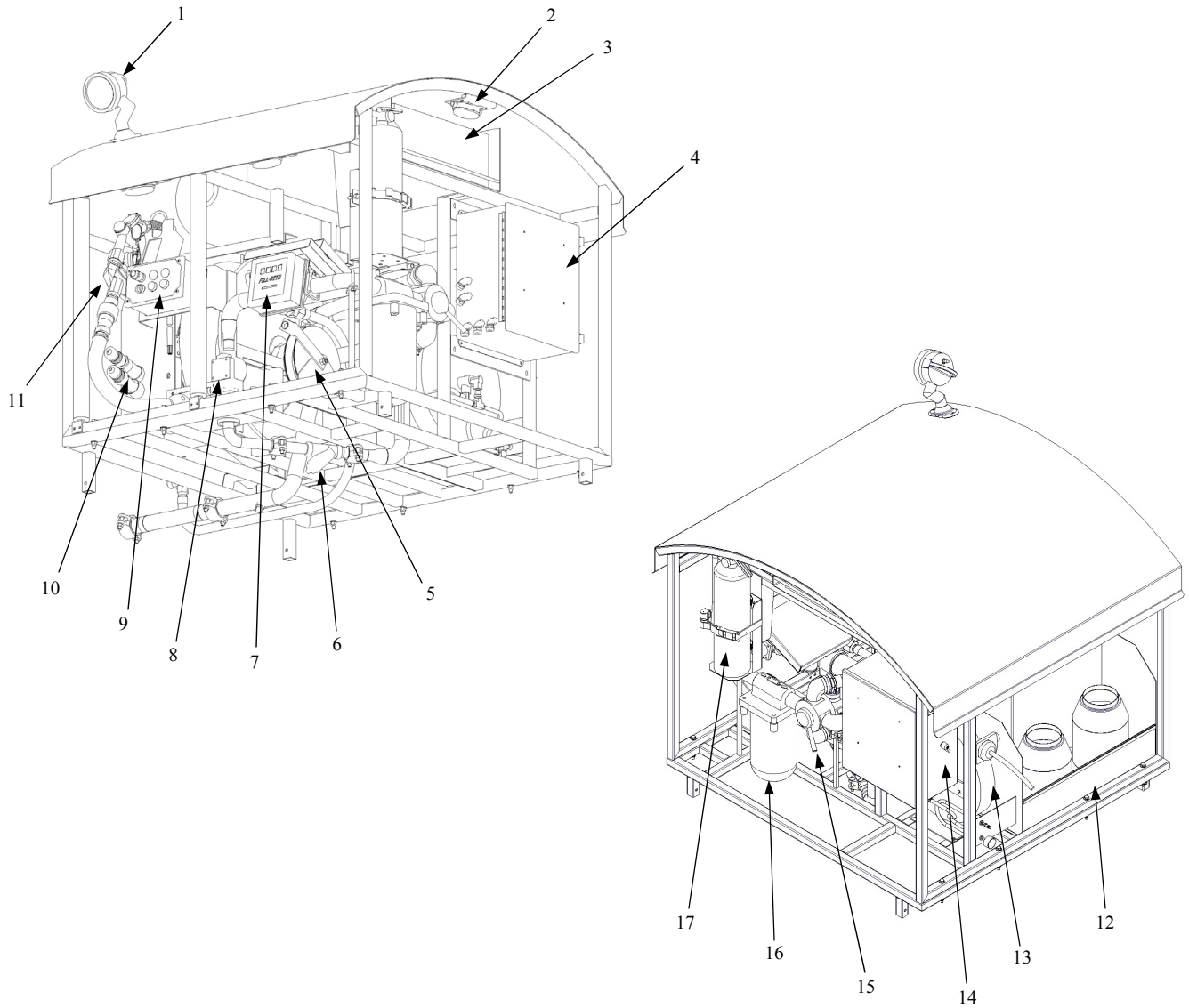

- |                          |                                   |
|--------------------------|-----------------------------------|
| 1. WORK LIGHT            | 10. FUEL EXTRACTION WANDS (QTY 2) |
| 2. CABINET LIGHT (QTY 4) | 11. FUELING NOZZLE                |
| 3. SPILL CONTAINMENT KIT | 12. FLUID STOWAGE                 |
| 4. MAIN ELECTRICAL PANEL | 13. AIR HOSE REEL                 |
| 5. GROUND/BOND REEL      | 14. BATTERY DIS-CONNECT           |
| 6. Y-STRAINER            | 15. FUEL METHOD SELECTION VALVE   |
| 7. FUEL METER            | 16. FUEL FILTER HOUSING           |
| 8. PUMP                  | 17. FIRE EXTINGUISHER             |
| 9. OPERATOR PANEL        |                                   |

**Figure 1-2. Component Identification - Continued.**

**Table 1-1. Leading Particulars for Model Number AGE400S-12VDC**

Tank Volume:	
Nominal Capacity.....	400-gallons
Max Capacity .....	440-gallons
Equipment Dimensions:	
Length (Tow bar down).....	221-inches
(Tow bar up).....	156-inches
Width (Tire to tire).....	77-inches
Height (Tow bar down).....	62-inches
(Tow bar up).....	72-inches
Weight (Empty) .....	2,280-pounds
(Full, at nominal capacity with fuel) .....	6,480-pounds
Ground Clearance (At tow bar).....	6-inches
(At axle) .....	8-inches
Environmental Conditions:	
Operating Temperature Range.....	-25°F to 110°F
Storage Temperature Range .....	-40°F to 150°F
Flow and Pressure:	
Fueling Flow Rate (nominal).....	11-GPM
Fueling Pressure .....	<10-PSI
Fuel Extraction Flow Rate (nominal).....	10-GPM
Fuel Extraction Suction (lift).....	10-FEET
Electrical Characteristics:	
Voltage.....	12VDC
On-board Batteries .....	Dual Optima Blue tops
On-board Charging.....	12VDC x 30-amp
Cabinet Lighting.....	LED
Circuit Protection.....	Yes, circuit breakers
Duty Cycle:	
Pump (Fueling and Extraction).....	30-minutes
Towing Characteristics:	
Speed, Forward Direction.....	15-MPH
Speed, Backward Direction .....	(hand push/pull only)
Turning Radius (Curb to curb) .....	372-inches
Tire Size and Pressure:	
Tire Size.....	20.5 x 8.0-10
Tire Pressure (Cold) .....	90-PSIG
Other Characteristics:	
Double Wall Construction.....	Yes
Tie-down Points.....	Yes, x 4 D-rings
Fork-lift Ready.....	Yes, 4 x 8 pockets

**Table 1-2. Leading Particulars for Model Number AGE600S-12VDC**

Tank Volume:	
Nominal Capacity.....	600-gallons
Max Capacity .....	660-gallons
Equipment Dimensions:	
Length (Tow bar down).....	221-inches
(Tow bar up).....	156-inches
Width (Tire to tire).....	77-inches
Height (Tow bar down).....	62-inches
(Tow bar up).....	72-inches
Weight (Empty) .....	2,780-pounds
(Full, at nominal capacity with fuel) .....	6,980-pounds
Ground Clearance (At tow bar).....	6-inches
(At axle) .....	8-inches
Environmental Conditions:	
Operating Temperature Range.....	-25°F to 110°F
Storage Temperature Range .....	-40°F to 150°F
Flow and Pressure:	
Fueling Flow Rate (nominal).....	12-GPM
Fueling Pressure .....	<10-PSI
Fuel Extraction Flow Rate (nominal).....	10-GPM
Fuel Extraction Suction (lift).....	10-FEET
Electrical Characteristics:	
Voltage.....	12VDC
On-board Batteries.....	Dual Optima Blue tops
On-board Charging.....	12VDC x 30-amp
Cabinet Lighting.....	LED
Circuit Protection.....	Yes, circuit breakers
Duty Cycle:	
Pump (Fueling and Extraction).....	30-minutes
Towing Characteristics:	
Speed, Forward Direction.....	15-MPH
Speed, Backward Direction .....	(hand push/pull only)
Turning Radius (Curb to curb) .....	372-inches
Tire Size and Pressure:	
Tire Size.....	20.5 x 8.0-10
Tire Pressure (Cold) .....	90-PSIG
Other Characteristics:	
Double Wall Construction.....	Yes
Tie-down Points.....	Yes, x 4 D-rings
Fork-lift Ready.....	Yes, 4 x 8 pockets



## CHAPTER 2

### SPECIAL TOOLS AND TEST EQUIPMENT

#### 2.1 GENERAL.

The HANDIFUELER is easy to use and easy to maintain. No special tools or equipment are needed to service this equipment.

#### 2.2 ELECTRICAL TEST EQUIPMENT.

A digital multi-meter is needed to test electrical continuity of various static bonding/grounding components used in the HANDIFUELER along with the electrical aspect of the equipment. A meter capable of reading milliohms is required to troubleshoot the equipment.



## CHAPTER 3

### PREPARATION FOR USE AND SHIPMENT

#### 3.1 PREPARATION FOR USE.

The following set of instructions should be followed prior to using the unit for the first time or preparing the HANDIFUELER for shipment.

#### 3.2 FIRST TIME USE.

**3.2.1 Un-packaging.** Un-package the HANDIFUELER by:

- a. Remove outer wrapping material.
- b. Remove equipment from pallet if palletized.

**3.2.2 Taking Inventory.** After all the components are removed from the packaging, conduct an inventory to ensure all loose items are present. See Table 3-1 for components listing.

#### 3.3 SHIPMENT.

The HANDIFUELER has been designed to be transported by truck or cargo aircraft.

**3.3.1 Preparation for Shipment.** Begin the shipping preprocess by following these steps:

- a. Drain the tank of all liquid products by running the unit dry and then by opening the drain plug.
- b. Evacuate all flammable and/or combustible vapors from the tank using an approved ventilation method.
- c. Ensure the Manway Assembly and Fill/Vent port is secured.

**3.3.2 Truck Shipment.** To load the HANDIFUELER on a truck, a forklift will be required.

- a. Ensure the steps in Paragraph 3.3.1 have been completed.
- b. Set the parking brake.
- c. Approach the unit from either side.
- d. Place on truck.
- e. Secure to truck bed using attachment points on tank weldment.

#### **WARNING**

Flammable and combustible vapors must be removed from the tank before shipping to prevent a fire and/or explosion. Serious injury or death could occur.

**3.3.3 Air Shipment.** The HANDIFUELER has been designed to be air transported. Specific aircraft loading procedures take precedence over the steps described here.

- a. Ensure the steps in Paragraph 3.3.1 have been completed.
- b. Follow specific aircraft loading requirements.
- c. Load equipment by towing forward only by self propelled tow methods or by hand pushing/pulling.
- d. After placement in aircraft, lock tow bar in upright position.
- e. Ensure Parking Brake is set.
- f. Ensure the Manway Assembly and Fill/Vent port is secured.

**Table 3-1. Component Inventory**

Description	Qty
Fuel Nozzle	1
Soft Fuel Extraction Wand	1
Hard Fuel Extraction Wand	1
Fire Extinguisher	1
Spill Containment Kit	1
On-board Batteries	2



# CHAPTER 4

## OPERATION INSTRUCTIONS

### 4.1 INTRODUCTION.

The instructions contained in this chapter provide step-by-step procedures for operating the HANDIFUELER. Both sizes are described in this chapter. See Chapter 5, Table 5-xx for “Pre-operation Inspection Check Sheet.”

### 4.2 GENERAL PRECAUTIONS.

Observe all WARNING, CAUTION, and NOTE headings throughout these instructions. Fuel is inherently flammable and/or combustible under many conditions. Fully understanding the safety and operational characteristics of the HANDIFUELER is crucial for successful and safe fuel handling operations.

### 4.3 CONTROLS AND INDICATORS.

Refer to Table 4-1 for descriptions and locations of all the controls and indicators.

### 4.4 OPERATION.

The HANDIFUELER is designed to perform two fuel servicing methods: Fueling and Fuel Extraction. The HANDIFUELER is also equipped to handle several other AGE servicing functions: tire service, fluid addition, and spill containment. Paragraph 4.5 describes supporting operations which are common to both methods of fuel servicing. Paragraph 4.6 describes the fueling and fuel extraction methods. Paragraph 4.7 describes non-fuel related functions. Finally, Paragraph 4.8 describes supplemental operations which are related to the HANDIFUELER operation, but are not related to AGE servicing at all.

**Table 4-1. Controls and Indicators**

Description	Function
Parking Brake Handle	Used to set the parking brake during operation and storage. Located at front of tank on left hand side.
Tow Bar Release	Releases the Tow Bar from the up-right locked position. Located at front of tank, centerline.
Liquid Level Gauge	Indicates level of the fluid inside the tank. Located on the top centerline of the tank.
Selection Valve	Selects Fuel Method: either Fueling or Fuel Extraction. Located at rear of unit.
Operator Console	Contains the operational controls of the equipment. Located left hand side, rear of unit.
Fuel Meter	Indicates amount of fuel delivered while using the Fueling Method. Located left hand side, rear of unit.
Battery ON/OFF Switch	Dis-connects the on-board batteries from the electrical system. (The unit can still be energized by the on-board battery charger or the 7-pin tow vehicle connector.) Located at rear of unit, right side.
Low-point Drain	Drains water from the low-point tank sump. Located rear of unit, left side.

## 4.5 SUPPORTING OPERATIONS.

Both methods of operation use one or more of these supporting operations. Instructions for each supporting operation is described below.

**4.5.1 Parking Brake.** The parking brake is applied by using the parking brake handle located at the front of the tank assembly. See Figure 4-1.

### CAUTION

The parking brake is not designed to stop the equipment if moving. Using the parking brake as a stopping brake will damage the brake system.

- Ensure the HANDIFUELER is at rest.
- To set parking brake, move handle so that it points upward.
- Chock equipment if required by local operating procedures.
- To release parking brake, move handle so that it points to the side.

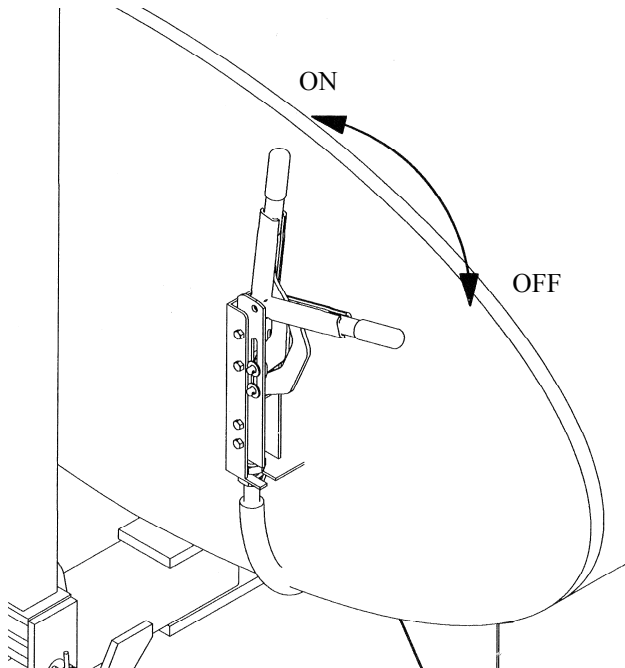

Figure 4-1. Parking Brake Handle

**4.5.2 Static Bonding/Grounding.** The static bonding/grounding reel is located at the rear of the tank assembly. Follow local protocol for static bonding/grounding procedures if different than described here. See Chapter 1, Figure 1-1.

- Ensure parking brake is set. See Paragraph 4.5.1 for instructions.
- Locate reel with clamp end (5) and pull cable outward until desired length has been taken out.
- Allow cable to retract until it stops.
- Attach to ramp at an approved bonding/ground location.
- To detach, reverse these steps.

**4.5.3 Liquid Level Gauge.** The liquid level gauge is located on top of the tank assembly, rear of the manway assembly. See Chapter 1, Figure 1-1, 4. The liquid level gauge should be checked prior to the Fuel Extraction Method.

### CAUTION

Do not overfill tank while extracting fuel. Fuel spill will result.

**4.5.4 Low-point Drain.** The Low-point drain is located at the rear bottom of the tank. It is operated by a pull cable (See Chapter 1, Figure 1-1) and plumbed to the out-board skid to facilitate operations.

- Park the HANDIFUELER as described in Paragraph 4.5.1.
- Position a container under the drain spout (6).
- Pull on the cable control (7) to open low-point drain.

**4.5.5 Filling the HANDIFUELER.** The HANDIFUELER is designed to be filled like a conventional fuel tank. See Chapter 1, Figure 1-1.

- Park the HANDIFUELER as described in Paragraph 4.5.1.
- Bond/ground unit as described in Paragraph 4.5.2.
- Open manway assembly (2) or use liquid level gauge (4) to observe fuel level.
- Open Fill/Vent port (3).
- Fill unit using Fill/Vent port (3) only.

4.5.6 **Work Lights.** The HANDIFUELER is equipped with cabinet lighting and a flood light for night time operations.

- a. Energize the unit by turning ON the Battery switch. See Figure 4-2, 1.
- b. Turn on the cabinet lighting by rotating the lighting switch on the operator's console. See Figure 4-3, 6.
- c. Turn on the flood light by locating and activating the ON/OFF toggle switch on the flood light itself. See Figure 4-2, 2.

**NOTE**

Flood light toggle switch only controls flood light. Cabinet light must be ON to operate flood light.

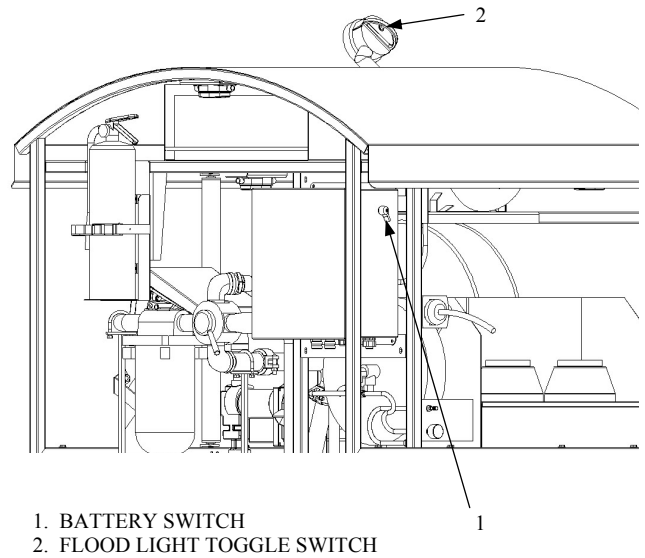

1. BATTERY SWITCH
2. FLOOD LIGHT TOGGLE SWITCH

**Figure 4-2. Battery and Flood Light Switches**

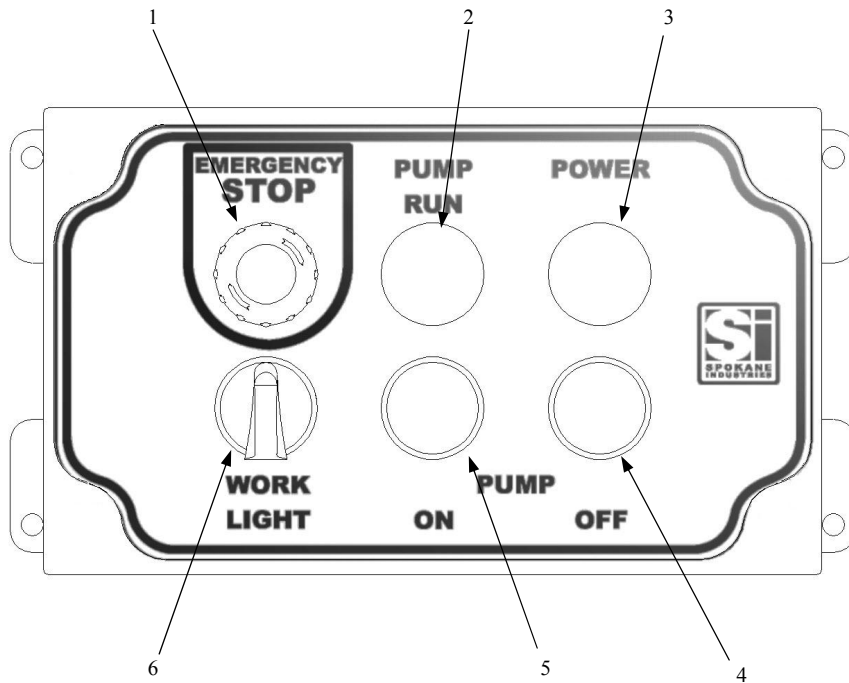

- |                               |                               |
|-------------------------------|-------------------------------|
| 1. EMERGENCY STOP PUSH BUTTON | 4. PUMP OFF PUSH BUTTON       |
| 2. PUMP RUN INDICATOR LIGHT   | 5. PUMP ON PUSH BUTTON        |
| 3. POWER ON INDICATOR LIGHT   | 6. WORK LIGHT SELECTOR SWITCH |

**Figure 4-3. Operator Console**

4.5.7 **Battery Charging.** The on-board batteries can be charged by two different means. Both methods are described in this paragraph.

4.5.7.1 **On-board battery charger.** The on-board battery charger uses 120-VAC to charge the on-board batteries.

- a. Park the HANDIFUELER as described in Paragraph 4.9.2.
- b. Open the main electrical panel. See Figure 4-4.
- c. Located the 120-VAC cord. Figure 4-4, 6
- d. Plug cord into a properly grounded 120-VAC, 15-amp receptacle.

**WARNING**

Only charge the on-board batteries in a dry location. An open electrical panel and charger operation can lead to a fire condition if flammable vapors are present.

4.5.7.2 **Tow Vehicle Charging.** The on-board batteries can also be charged by connecting the HANDIFUELER'S 7-pin trailer connection into a properly wired 7-pin connection point. See Chapter 6 for wiring schematic.

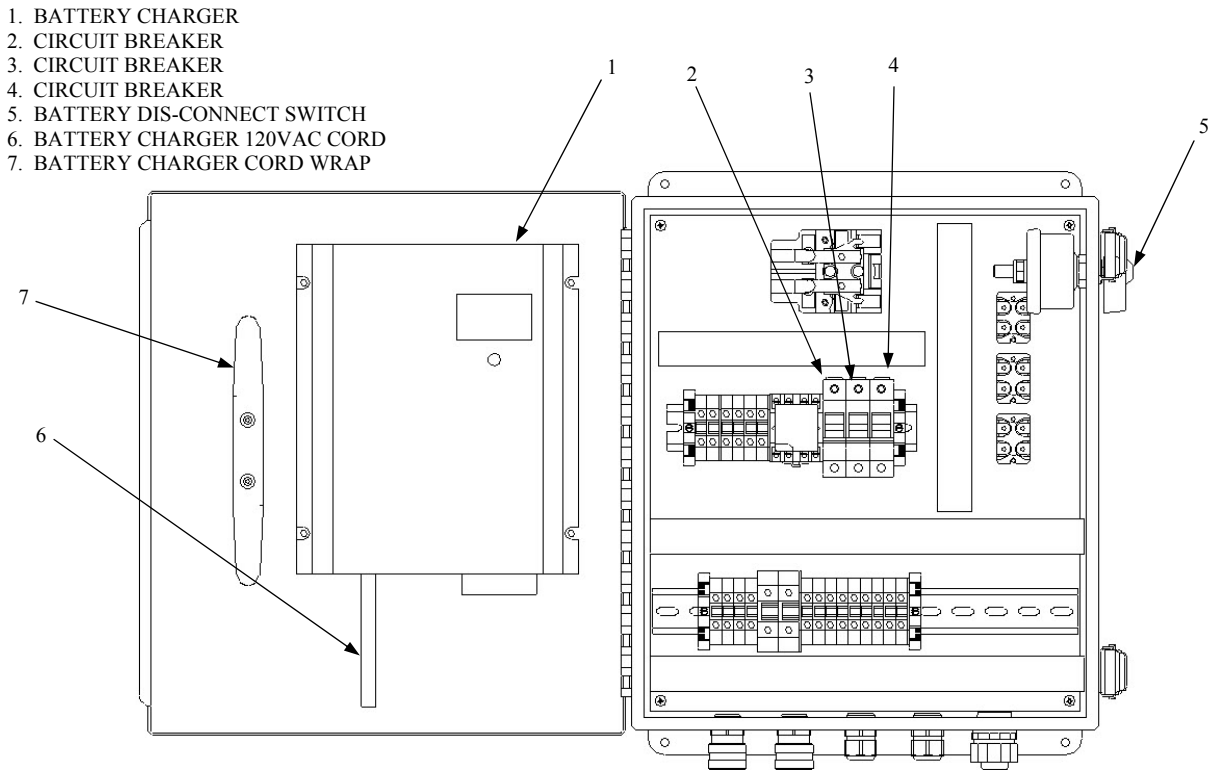

Figure 4-4. Main Electrical Panel

## 4.6 FUEL SERVICE METHODS

Both methods of fuel servicing involve the addition or removal of flammable liquids. Caution should be used whenever flammable liquids are being handled.

### WARNING

Fuel and fuel vapors are inherently flammable. Operations involving fuel should not be conducted near open flames or where electrical arcs could ignite the fuel or fuel vapors. Serious injury or death could result.

**4.6.1 Fueling.** The Fueling method of operation is described in this paragraph.

- a. Position the HANDIFUELER within reach of the 35-foot fuel hose.
- b. Set the Parking Brake as described in Paragraph 4.5.1.
- c. Attach the Static/Bonding Reel as described in Paragraph 4.5.2.
- d. Ensure that the Fuel Nozzle is attached to the fuel hose.
- e. Position the Selection Valve to the “FUEL” position. See Chapter 1, Figure 1-2, 15.
- f. Energize the unit by turning ON the Battery switch. See Figure 4-2.
- g. Start the fuel pump by depressing the “PUMP ON” button located on the operator console. See Figure 4-3, 5.
- h. Remove Fuel Nozzle from the holder and stretch out the appropriate amount of hose to reach the point being fueled. The hose reel will lock in position when pulling has ceased.
- i. Start fueling by depressing the fuel nozzle handle.
- j. Stop fueling by releasing the fuel nozzle handle.
- k. Stop the fuel pump by depressing the “PUMP OFF” button located on the operator console. See Figure 4-4, 4.
- l. Retract fuel hose by pulling on retracted hose and allow the hose reel to start retrieving hose. Control the rate of retraction by providing a small amount of resistance against the hose reel. Do not let fuel hose approach its stop at a high rate of speed.

- m. De-energize the unit by turning OFF the Battery switch.

**4.6.2 Fuel Extraction Method.** The Fuel Extraction method of operation is described in this paragraph. Note: The fueling being extracted is pumped through the filter housing and should be acceptable to use in other AGE.

### CAUTION

Do not overfill tank while extracting fuel. Fuel spill will result.

- a. Position the HANDIFUELER within reach of the 35-foot fuel hose.
- b. Set the Parking Brake as described in Paragraph 4.5.1.
- c. Attach the Static/Bonding Reel as described in Paragraph 4.5.2.
- d. Select the appropriate Fuel Extraction wand and attached to the fuel hose.
- e. Position the Selection Valve to the “DE-FUEL” position. See Chapter 1, Figure 1-2, 15.
- f. Energize the unit by turning ON the Battery switch. See Figure 4-2.
- g. Position the fuel hose by stretching it out the appropriate amount to reach the point where fuel is being extracted. The hose reel will lock in position when pulling has ceased.
- h. Start the fuel pump by depressing the “PUMP ON” button located on the operator console. See Figure 4-3, 5.
- i. Stop the fuel pump by depressing the “PUMP OFF” button located on the operator console. See Figure 4-3, 4.
- j. Retract fuel hose by pulling on retracted hose and allow the hose reel to start retrieving hose. Control the rate of retraction by providing a small amount of resistance against the hose reel. Do not let fuel hose approach its stop at a high rate of speed.
- k. De-energize the unit by turning OFF the Battery switch.
- l. Return the used Fuel Extraction wand to its holder.

## 4.7 NON-FUEL RELATED FUNCTIONS

**4.7.1 Pneumatic Air Tank.** The HANDIFUELER is equipped with a 10 gallon, 125psi air tank, hose reel, and air chuck for field servicing of AGE pneumatic tires. This paragraph describes the tank filling and tire filling operations.

**4.7.1.1 Air Tank Filling.** To fill the HANDIFUELER air tank, follow the steps described below:

- a. Position the HANDIFUELER within reach of the compressed air source.
- b. Set the Parking Brake as described in Paragraph 4.5.1.
- c. Remove cap from Schrader valve at Tire Service Panel. See Figure 4-5, 2.
- d. Using a standard air chuck, fill air tank from compressed air source.
- e. Observe tank pressure.
- f. Tank is full when gage reads 125psi or pressure relief valve opens. See Figure 4-5, 3.
- g. Disconnect compressed air source and replace Schrader valve cap.

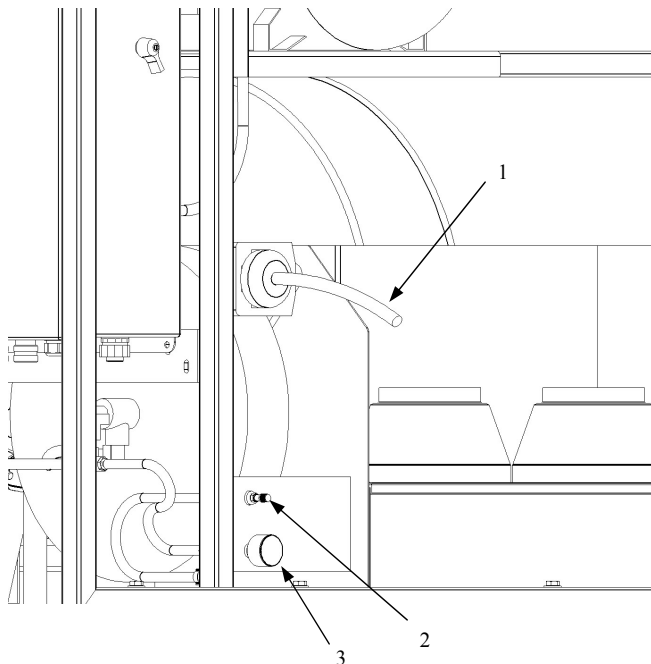

1. AIR HOSE AND CHUCK
2. SCHRADER VALVE
3. PRESSURE GAUGE

**Figure 4-5. Pneumatic Air Tank**

**4.7.1.2 AGE Tire Service.** To service AGE tires, follow the steps described below:

- a. Position the HANDIFUELER within reach of the 25-foot pneumatic hose reel.
- b. Set the Parking Brake as described in Paragraph 4.5.1.
- c. Located the pneumatic air chuck and hose and position them by pulling on the hose. The hose reel will lock into position. See Figure 4-5, 1.
- d. Service the tire.

## 4.8 SUPPLEMENTAL OPERATIONS.

Supplemental operations are not specific to either a major mode of operation or a supporting operation. Supplemental operation instructions are described in the following paragraphs.

**4.8.1 Towing the HANDIFUELER.** The HANDIFUELER can be towed by means of self propelled tow apparatus or by pushing/pulling by hand.

- a. Ensure that all hoses, static bonding/grounding cables, and tools are properly stored and all valves are closed.
- b. (See Figure 4-6). Release Tow Bar from the up-right position by applying foot pressure to Toe Latch (reference arrow A) and swing Tow Bar downward (reference arrow B).
- c. Attach to tow apparatus if not being pushed/pulled by hand.
- d. Release parking brake (reference arrow C). See Paragraph 4.5.1 for instructions.
- e. While towing, observe towing speed and turning radius restrictions in Tables 1-1 and 1-2.
- f. If towing with a self propelled apparatus, do not back unit.

### CAUTION

Do not back equipment by any means other than hand pushing/pulling. Damage to the equipment will occur if self propelled tow methods are employed.

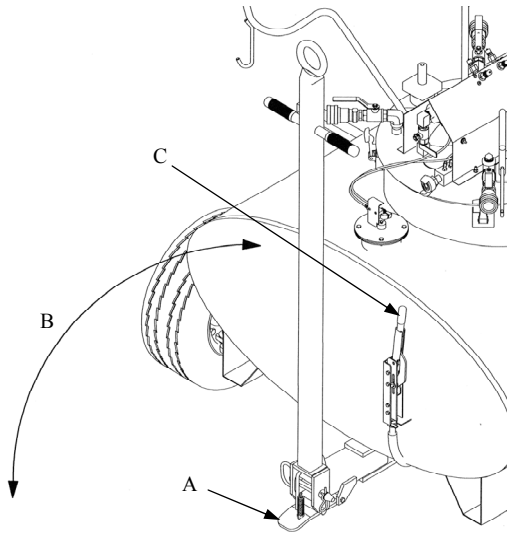

**Figure 4-6. Releasing The Tow Bar**

**4.8.2 Parking the HANDIFUELER.** The following steps describe how to park the HANDIFUELER.

- a. Place HANDIFUELER in approved area.
- b. Set parking brake. See Paragraph 4.5.1 for instructions.
- c. Attach static bonding/grounding reels. See Paragraph 4.5.2 for instructions.
- d. Ensure that the Battery Disconnect switch is OFF.
- e. Ensure Manway Assembly is closed and latched.

**4.8.3 Draining the HANDIFUELER.** The tank drain is located at the rear of the tank assembly. (See Figure 4-7).

- a. Ensure the parking brake is set. See Paragraph 4.5.1 for instructions.
- b. Attach static bonding/grounding reels. See Paragraph 4.5.2 for instruction.

- c. Use the fuel pump to empty tank contents into a safe container.
- d. Open low-point sump valve and allow remainder of fuel to drain. See Chapter 1, Figure 1-1, 5.
- e. Open petcock drain on filter (see Figure 4-7, 1) to drain fuel from filter housing.
- f. Remove pipe plugs (see Figure 4-7, 2) to drain fuel from the plumbing system.

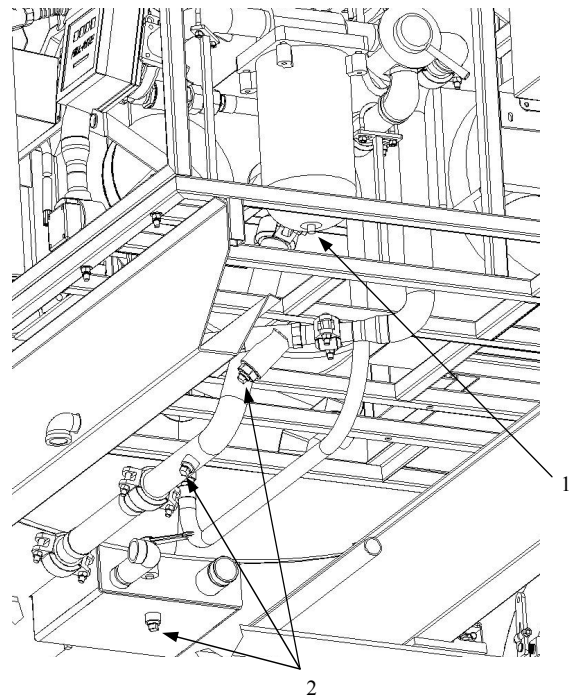

**Figure 4-7. Drain Points**



# CHAPTER 5

## MAINTENANCE INSTRUCTIONS

### 5.1 OPERATIONAL CHECKOUT.

Operational checkout is performed during the course of normal operation. While the HANDIFUELER is operating normally, it may be assumed that no repair is required. However, the preventive maintenance procedures may be performed at regular intervals or in accordance with standard shop procedures; which ever is more suitable.

### 5.2 INSPECTION AND PREVENTIVE MAINTENANCE.

**5.2.1 Inspection.** Prior to each day's use, determine that the equipment is in serviceable condition by performing a daily inspection. A daily inspection check sheet is illustrated in Table 5-8.

**5.2.2 Preventive Maintenance.** Paragraph 5.5 contains preventive maintenance items and intervals.

### 5.3 REPAIR AND REPLACE INSTRUCTIONS.

#### **WARNING**

The parking brakes must be set while performing maintenance procedures. Approved jack stands and wheel chocks must also be used. Serious injury or death may occur from rolling, or falling equipment.

The following procedures are for the disassembly, repair, replacement, and reassembly of the various component groups of the equipment. Perform only those steps necessary to effect the desired repairs.

**5.3.1 General Tank Equipment.** This procedure covers all components attached to the tank by means of threaded pipe connections. No specific maintenance instructions for disassembly or reassembly are needed for components attached to the tank by pipe threads. The following maintenance steps describe how to properly apply pipe joint sealing compounds. Pipe joint sealing compounds should be approved for fuel service.

#### **WARNING**

Ensure that the tank is free of fuel and flammable and/or combustible vapors before performing any maintenance operation involving the tank. Serious injury or death could occur.

- a. Remove component(s) that need to be repaired or replaced.
- b. Remove old pipe sealing compound from component (s) by wire brush or approved solvent. If solvent is used, allow component(s) to dry before proceeding.
- c. Inspect threads for damage. Replace component(s) that have damage.
- d. Apply an even coat of pipe joint sealing compound across and all the around the first four threads. The coat thickness should fill the thread "valleys", and no more.
- e. Hand start the threaded component(s) and tighten until hand-tight. Do not cross thread components.
- f. Tighten component(s) until a leak-free connection is achieved.

**5.3.2 Manway Assembly.** The manway assembly is located on the top of the tank. The manway assembly has one adjustment point, see Paragraph 5.3.2.2 for adjustment steps. Use Figure 5-1 for the following maintenance steps.

#### **5.3.2.1 Disassembly/Reassembly Steps.**

- a. Open handle (2).
- b. Open Manway Assembly.
- c. Remove nut (7).
- d. Remove gasket retainer (5), gasket (4), and lid (3).
- e. Remove bolt (6) and nut (10) to remove cross-arm (1).
- f. Repair/replace components
- g. Reassemble in reverse order, leaving nut (7) only partially threaded onto cross arm (1).
- h. Adjust manway as indicated in Paragraph 5.3.2.2, starting at step (b).

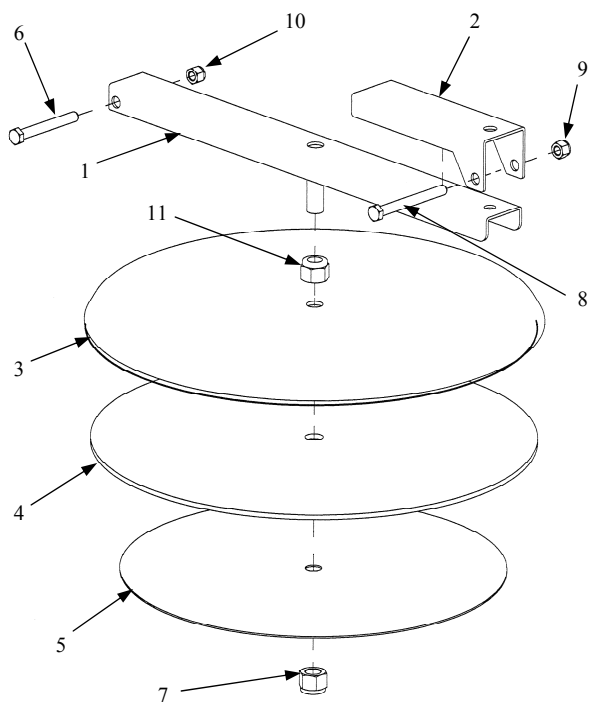

- |                    |                    |
|--------------------|--------------------|
| 1. CROSS ARM       | 7. CROSS ARM NUT   |
| 2. FLIP LOCK       | 8. FLIP LOCK BOLT  |
| 3. LID             | 9. FLIP LOCK NUT   |
| 4. GASKET          | 10. NUT            |
| 5. GASKET RETAINER | 11. ADJUSTMENT NUT |
| 6. CROSS ARM BOLT  |                    |

**Figure 5-1. Manway Assembly**

**5.3.2.2 Adjustment.** Perform the following procedures to adjust the manway assembly.

- Open handle (2).
- Open Manway Assembly.
- Rotate nut (11) to adjust lid position. Turn clockwise to move lid closer to the tank. Turn counter clockwise to move the lid away from the tank.
- Tighten nut (7) until snug.

**5.3.3 Front Undercarriage Assembly.** The Front Undercarriage assembly consists of a front wheel assembly (See Paragraph 5.3.3.1), a hub assembly (See Paragraph 5.3.3.2), a spindle assembly (See Paragraph 5.3.3.3), a tow latch assembly (See Paragraph 5.3.3.4), a steering arm assembly (See Paragraph 5.3.3.5), and an adjustable tie rod assembly (See Paragraph 5.3.3.6). The Wheel Assembly is discussed in Paragraph 5.3.5.

**5.3.3.1 Front Wheel Assembly Removal.** To remove the wheel assembly, the equipment must have the front end raised and placed on approved jack stands.

- Raise equipment with suitable maintenance jack (See Figure 5-2, reference arrow A for jack placement) high enough to remove wheel assembly.
- Place approved jack stands under front axle (see Figure 5-2, reference arrow B for stand placement).
- Remove lug nuts of wheel assembly needing maintenance, and remove.

**WARNING**

Use suitable lifting and support equipment when performing these steps. Serious injury or death could occur from rolling or falling equipment.

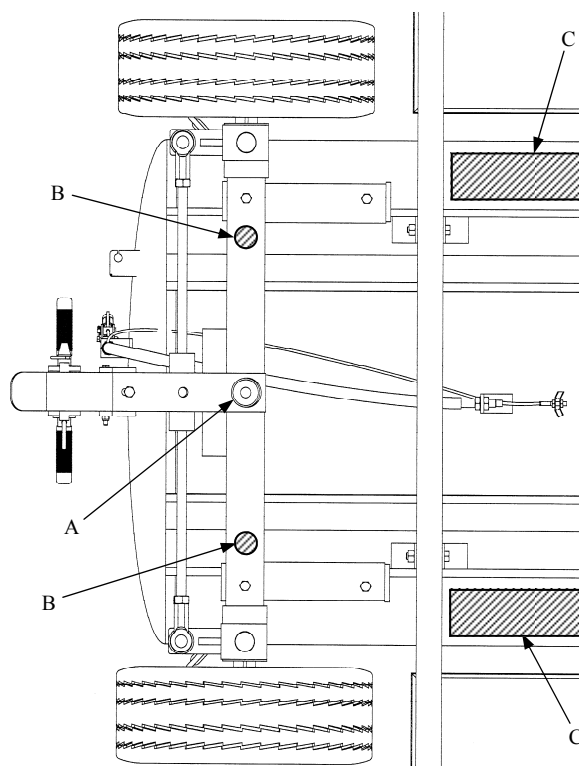

**Figure 5-2. Generic Undercarriage Lift Points**

**5.3.3.2 Front Hub Assembly.** To remove the front hub assembly, follow the maintenance steps in Paragraph 5.3.3.1 before beginning the next steps. (See Figure 5-3).

- a. Remove dust cap (1) by lightly tapping with a rubber hammer.
- b. Remove cotter pin (2), castle nut (3), and washer (4).
- c. Grasp front hub (7) and pull outward firmly. Ensure that bearing (5) doesn't fall from hub and strike the ground.
- d. Remove bearing (5), seal (10), and bearing (9) from the front hub (7).
- e. Using a suitable H-frame press, remove bearing races (6) and (8).
- f. Replace components and grease bearings before reassembly.
- g. Reassemble in reverse order. Castle nut (3) should be tightened until the hub assembly rotates barely past free.

**5.3.3.3 Spindle Assembly.** To remove the spindle assembly, follow the maintenance steps in Paragraph 5.3.3.2 before beginning the next steps. (See Figure 5-6).

- a. Remove nut (17) and washer (16).
- b. Remove nut (21) and washer (20).

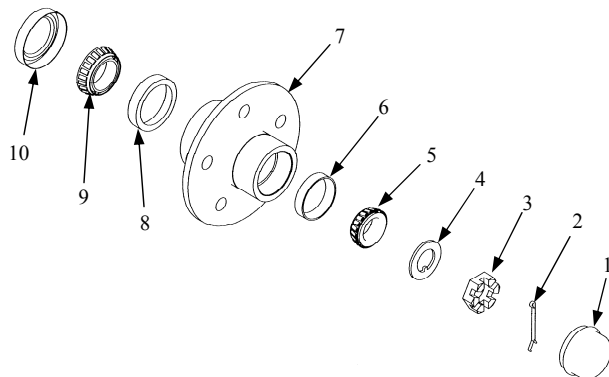

- |                  |                  |
|------------------|------------------|
| 1. DUST CAP      | 6. OUTER RACE    |
| 2. COTTER PIN    | 7. HUB           |
| 3. CASTLE NUT    | 8. INNER RACE    |
| 4. WASHER        | 9. INNER BEARING |
| 5. OUTER BEARING | 10. SEAL         |

**Figure 5-3. Front Hub Assembly**

- c. Remove king pin (14) from yoke by using a rubber hammer.
- d. Grasp spindle assembly (18) and rotate toward front of tank until free of yoke. Remove spindle assembly from tie rod (15).
- e. Remove bushings (19) with bronze punch and hammer.
- f. Repair/replace components.
- g. Reassembly in reverse order. Nut (21) should not be tightened past snug.

**5.3.3.4 Tow Latch Assembly.** The tow latch assembly is used to secure the tow bar in the upright position. (See Figure 5-4).

- a. Remove tow bar (1) by placing the tow bar in upright, latched position. Remove hair pin (2). While holding onto tow bar, place foot on toe latch assembly (See reference arrow A) and depress.
- b. Pull hitch pin (3) from steering arm assembly and place tow bar to the side.

**NOTE**

Removing hitch pin from steering arm assembly will free tow bar. Prevent tow bar from falling by holding it firmly until free. Set aside.

- c. See Figure 5-6 for the remaining steps. Remove bolt (7) and nut (10).
- d. Rotate toe latch plate (9) downward to free from assembly.
- e. Detach spring (8) from toe latch plate (9) and spring anchor (24).

**5.3.3.5 Steering Arm Assembly.** To remove the steering arm assembly, follow the maintenance steps in Paragraph 5.3.3.4 before beginning the next steps. (See Figure 5-6).

- a. Remove thin lock nut (1). Remove nuts (17) and flat washers (16).
- b. Remove bolts (22) and nuts (5). Allow lower steering arm subassembly (11), bushing (3), and tie rod assembly (12) to drop down; place to the side.

1. TOW BAR
2. HAIR PIN
3. HITCH PIN

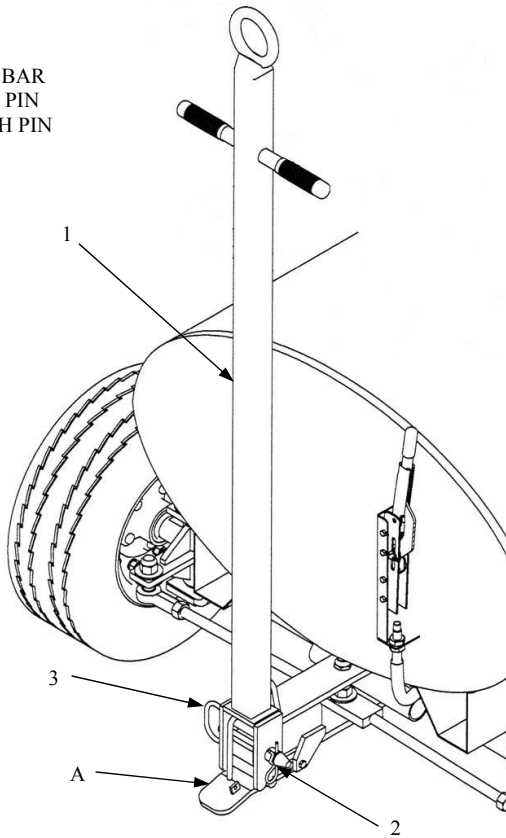

**Figure 5-4. Tow Bar Removal**

- c. Lift upper steering arm subassembly vertically to clear pivot pin (reference arrow A), then pull outward to clear tank and front axle tube.
- d. Remove tie rod assembly (12) by removing nut (6) and flat washer (4). Note presence of bushings (23).
- e. Repair / replace components.
- f. Reassemble in reverse order.

**5.3.3.6 Tie Rod Assembly.** The tie rod assembly is removed by the following steps. (See Figure 5-6).

- a. Start by following the steps in Paragraph 5.3.3.5. Note presence and location of bushings (23) when removing tie rod assembly from steering arm assembly.
- b. Disassembly tie rod assembly by unthreaded components. Before disassembly, mark tie rod length with masking tape.

- c. Repair/replace components.
- d. Reassemble in reverse order. Note that tie rod ends angle downward toward tie rod ends when reassembling.
- e. Adjust tire toe in /toe out as needed.

**5.3.3.7 Front Undercarriage Assembly Removal.** To remove the entire Front Undercarriage assembly, the equipment must have the front end raised. See Figure 5-5 for these steps.

**WARNING**

The Front Undercarriage will become unstable when the wheels make contact with the ground. Serious injury could result from unexpected movement if proper attention is not being observed.

- a. Raise equipment with suitable maintenance jack (see Figure 5-2, reference arrow A for jack placement) to allow for 4-inches of space between the wheels and the ground.

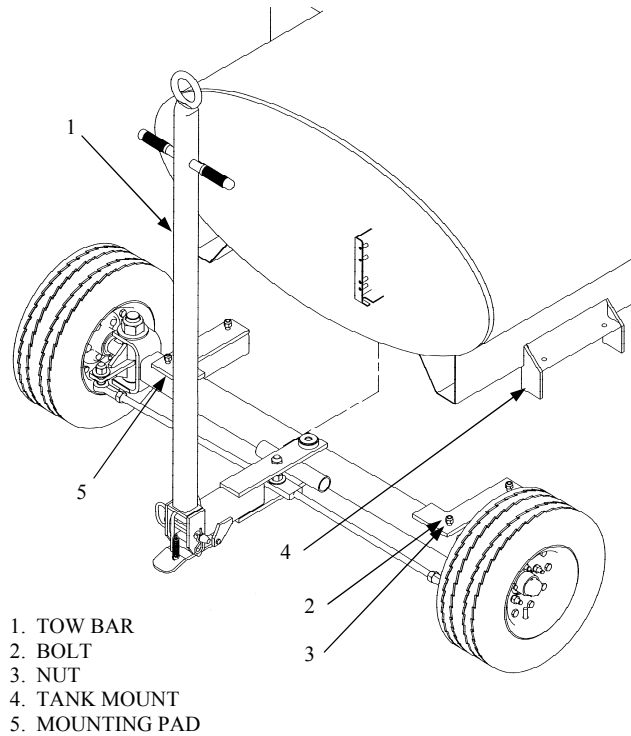

1. TOW BAR
2. BOLT
3. NUT
4. TANK MOUNT
5. MOUNTING PAD

**Figure 5-5. Removal of Front Undercarriage**

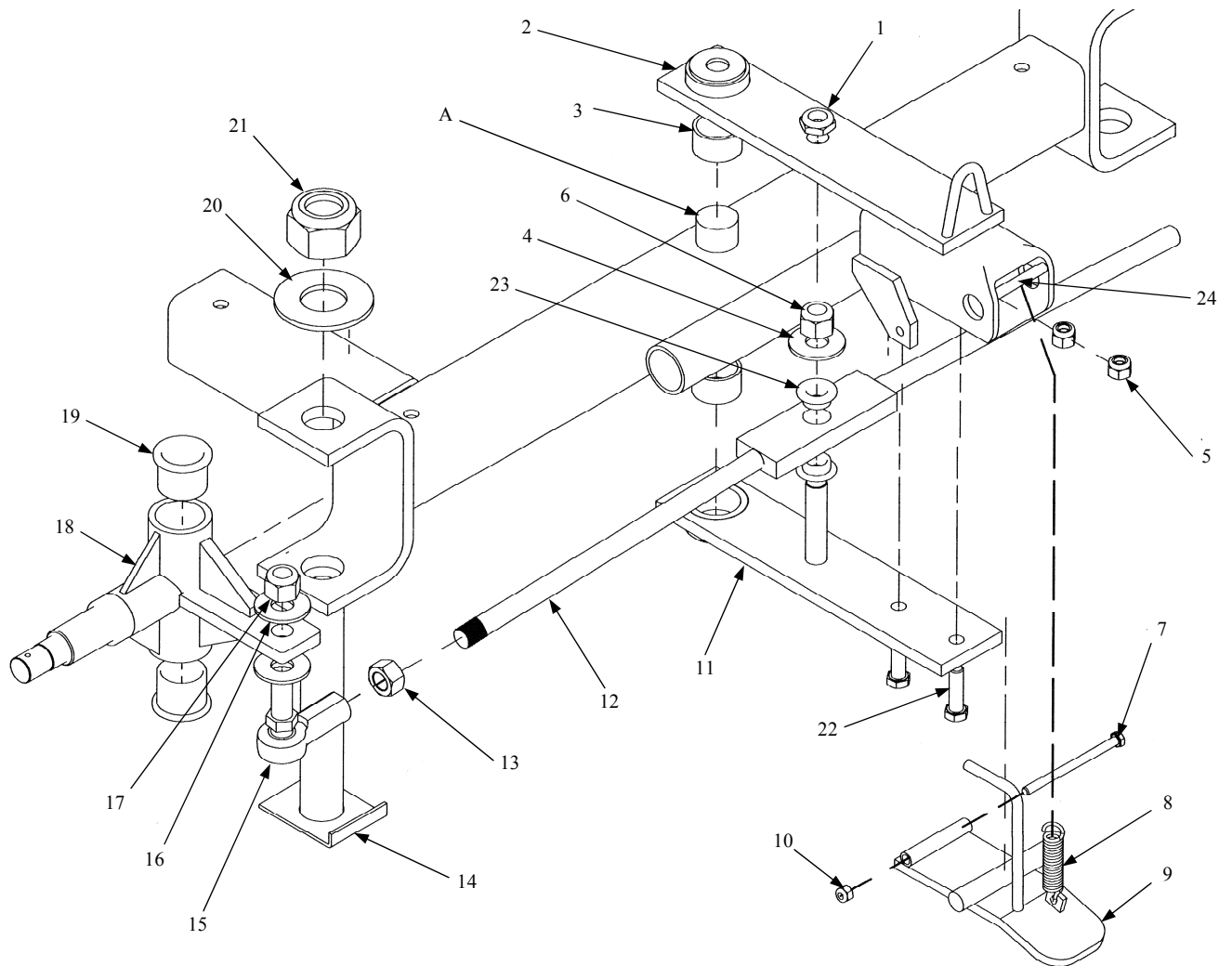

- |                       |                        |                      |                      |
|-----------------------|------------------------|----------------------|----------------------|
| 1. THIN LOCK NUT      | 7. BOLT                | 13. JAM NUT          | 19. KING PIN BUSHING |
| 2. UPPER STEERING ARM | 8. SPRING              | 14. KING PIN         | 20. FLAT WASHER      |
| 3. PIVOT BUSHING      | 9. TOE LATCH           | 15. TIE ROD END      | 21. KING PIN NUT     |
| 4. FLAT WASHER        | 10. NYLON INSERT NUT   | 16. FLAT WASHER      | 22. BOLT             |
| 5. NYLON INSERT NUT   | 11. LOWER STEERING ARM | 17. NYLON INSERT NUT | 23. TIE ROD BUSHING  |
| 6. NYLON INSERT NUT   | 12. TIE ROD ASSY       | 18. SPINDLE ASSEMBLY | 24. SPRING ANCHOR    |

**Figure 5-6. Front Undercarriage Exploded Assembly**

- b. Place cribbing under tank skids (see Figure 5-2, reference points C) to safely support the equipment.
- c. Lower onto cribbing. Leave jack in place.
- d. Place tow bar (1) in the up position.
- e. Raise jack to apply slight pressure on assembly.
- f. Remove bolts (2) and nuts (3).
- g. Carefully lower jack and assembly until wheels are on the ground and front axle tube clears tank mounts (4).
- h. Pull Front Undercarriage forward. Note location of rubber mounting pads (5).
- i. Reassembly in reverse order.

5.3.4 **Rear Undercarriage Assembly.** See Figure 5-16 for the following maintenance steps. The rear undercarriage assembly consists of: a wheel assembly, a hub and brake drum assembly (1), a mechanical parking brake assembly (2), a rear spindle (4), and the axle (10).

**WARNING**

Use suitable lifting and support equipment when performing these steps. Serious injury or death could occur from rolling or falling equipment.

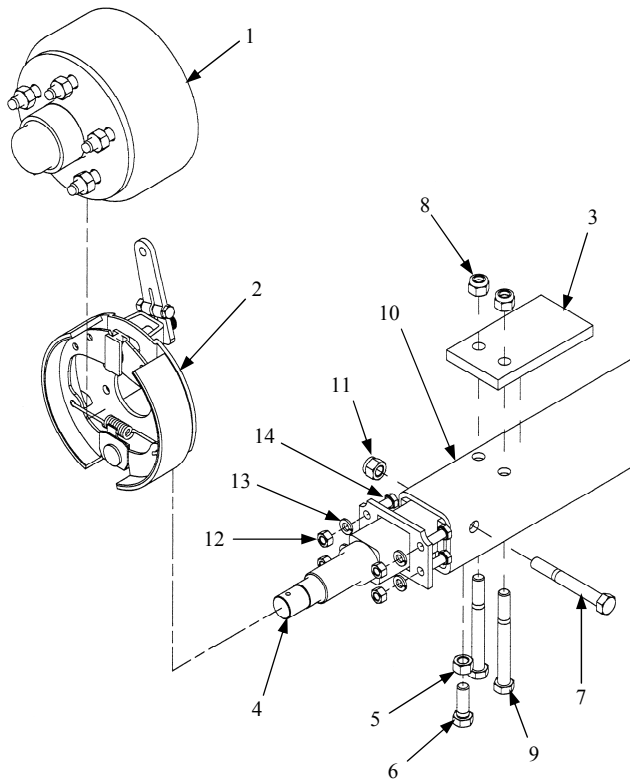

- |                       |                      |
|-----------------------|----------------------|
| 1. REAR HUB/DRUM ASSY | 8. NYLON INSERT NUT  |
| 2. MECHANICAL BRAKE   | 9. MOUNT BOLT        |
| 3. RUBBER PAD         | 10. REAR AXLE        |
| 4. SPINDLE            | 11. NYLON INSERT NUT |
| 5. JAM NUT            | 12. BRAKE NUT        |
| 6. PINCH BOLT         | 13. BRAKE WASHER     |
| 7. BOLT               | 14. BRAKE BOLT       |

**Figure 5-7. Rear Undercarriage**

**NOTE**

Figure 5-2 is generic for both the Front Undercarriage and Rear Undercarriage. Points A and B are similar on both axles.

5.3.4.1 **Rear Wheel Assembly Removal.** To remove the wheel assembly, the equipment must have the back end raised and placed on approved jack stands.

- a. Raise equipment with suitable maintenance jack (See Figure 5-2, reference arrow A for jack placement) high enough to remove wheel assembly.
- b. Place approved jack stands under rear axle (See Figure 5-2, reference arrow B for stand placement).
- c. Remove lug nuts of wheel assembly needing maintenance, and remove.

5.3.4.2 **Rear Hub/Brake Drum Assembly.** To remove the rear hub and brake drum assembly, follow the maintenance steps in Paragraph 5.3.4.1 before beginning the next steps. (See Figure 5-8).

- a. Remove dust cap (1) by lightly tapping with a rubber hammer.
- b. Remove cotter pin (2), castle nut (3), and washer (4).
- c. Grasp front hub (7) and drum (8). Pull outward firmly. Ensure that bearing (5) doesn't fall from hub and strike the ground.
- d. Remove bearing (5), seal (11), and bearing (10) from the rear hub (7).
- e. Using a suitable H-frame press, remove bearing races (6) and (9).
- f. Remove drum (8) by pressing out wheel studs (12) in suitable H-frame press.
- g. Replace components and grease bearings before reassembly.
- h. Reassemble in reverse order. Castle nut (3) should be tightened until the hub assembly rotates barely past free.

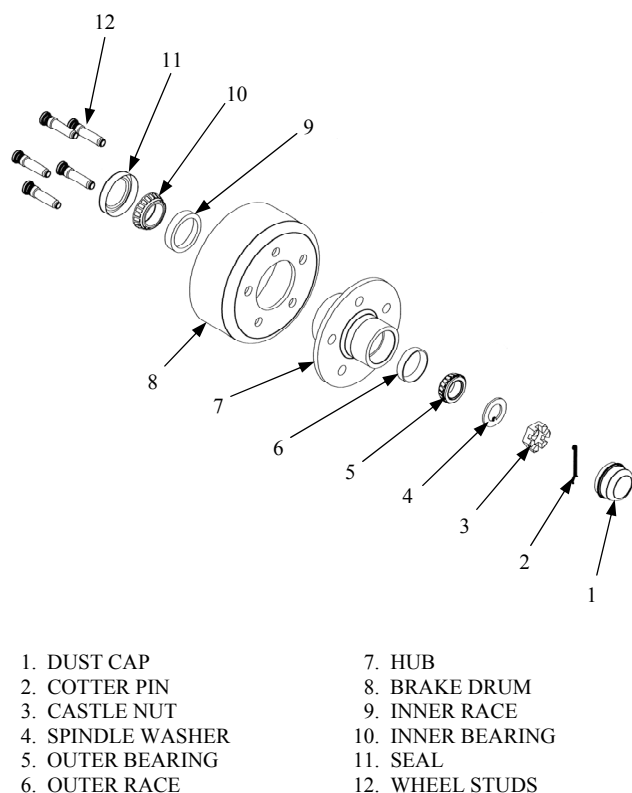

**Figure 5-8. Rear Hub and Brake Drum**

**5.3.4.3 Parking Brake Assembly.** The parking brake assembly consists of a brake handle and cable assembly (See Paragraph 5.3.4.3.1), and a mechanical brake assembly (See Paragraph 5.3.4.3.2). The parking brake assembly is adjusted by following the instructions in Paragraph 5.3.4.3.3.

**5.3.4.3.1 Brake Handle and Cable Assembly.** The brake handle and cable assembly only need to be disassembled to the point that the repair is needed. These instructions start at the wheel assembly and progress toward the brake handle. (See Figure 5-11).

- a. Remove cotter pin (12) and clevis pin (13) to release clevis (11).
- b. Unthread clevis (11) from cable (10).
- c. Remove nut (14) and remove cable housing (10) from bracket.
- d. Remove nut at opposite end of cable and disassemble cable linkage parts (6), (7), (8), and (9).

- e. Repeat steps a. through d. for opposite side.
- f. Remove nut (4) to release cable equalizer (5).
- g. Repeat step c. for cable housing leading to brake handle.
- h. Remove nut at opposite end of cable and release cable by disassembling cable linkage from brake handle (1).
- i. Remove bolts (2) and nuts (3) to free brake handle (1).
- j. Reassembly in reverse order.

**5.3.4.3.2 Mechanical Brake Assembly.** The mechanical brake assembly is disassembled by following the steps described here. The assembly can be disassembled while attached to the rear spindle or removed from the unit. (See Figure 5-9).

- a. Remove Rear Wheel Assembly as described in paragraph 5.3.4.1.
- b. Remove Rear Hub and Brake Drum Assembly as described in Paragraph 5.3.4.2
- c. Remove brake cable end from arm (5) as described in Paragraph 5.3.4.3.1, step (a).

**NOTE**

Steps (d) and (e) are needed only if Mechanical Brake Assembly is to be removed from the axle.

- d. Remove nuts (12), washers (13), and bolts (14) shown in Figure 5-7.
- e. Remove mechanical brake assembly and place on flat surface.
- f. Remove spring (3).
- g. Release brake shoes (2) by removing springs (9) from the backing plate (1).
- h. Remove nut (7), lock washer (8), and bolt (6) to release arm (5).
- i. Remove brake cam (4) by pulling directly outward.
- j. Reassembly in reverse order.

**5.3.4.3.3 Parking Brake Adjustment.** The parking brake can be adjusted at three different locations. An in-field adjustment can be made at the brake handle by turning the handle cap clockwise to tighten brakes and counter-clockwise to loosen the brakes (See reference arrow D.) This adjustment must be made with the brake handle in the off position. Maintenance level adjustments can be made at reference arrow E and reference arrow F (each side). See Figure 5-11.

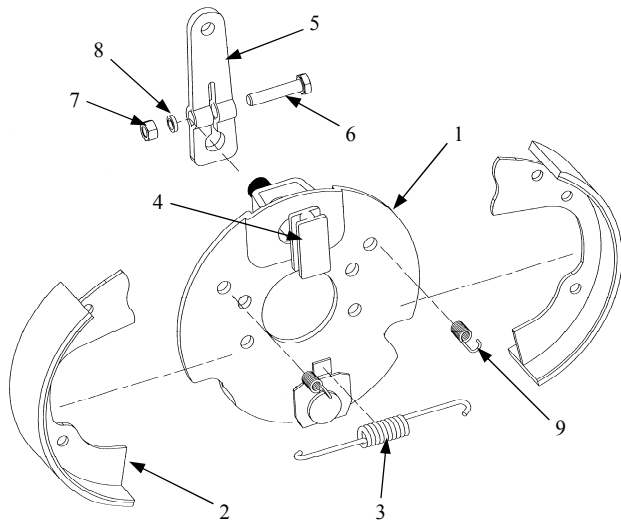

- |                  |                     |
|------------------|---------------------|
| 1. BACKING PLATE | 6. BOLT             |
| 2. BRAKE SHOE    | 7. NUT              |
| 3. SPRING        | 8. LOCK WASHER      |
| 4. CAM BOLT      | 9. HOLD DOWN SPRING |
| 5. CAM ARM       |                     |

**Figure 5-9. Mechanical Parking Brake**

**5.3.4.4 Rear Spindle.** To remove the rear spindle, follow the maintenance steps described in this paragraph. (See Figure 5-7).

- Remove Rear Wheel Assembly as described in Paragraph 5.3.4.1 for the side needing repair.
- Remove Rear Hub and Brake Drum as described in Paragraph 5.3.4.2 for the side needing repair.
- Remove Mechanical Brake Assembly as described in Paragraph 5.3.4.3.2 for the side needing repair.
- Loosen jam nut (5) and remove bolt (6).
- Remove nut (11) and bolt (7).
- Pull rear spindle (4) directly outward to free from axle tube (10).
- Reinstall in reverse order.

**5.3.4.5 Rear Undercarriage Assembly Removal.** To remove the entire Rear Undercarriage assembly, the equipment must have the back end raised. See Figure 5-7 for these instructions.

**WARNING**

Use suitable lifting and support equipment when performing these steps. Serious injury or death could occur from rolling or falling equipment.

- Raise equipment with suitable maintenance jack (See Figure 5-2, reference arrow A for jack placement) and allow for 2-inches of space between the wheels and the ground.
- Place cribbing under tank skids (See Figure 5-2, reference points C) to safely support the equipment.
- Lower onto cribbing. Leave jack in place.
- Disconnect parking brake cables at mechanical brake assembly as described in Paragraph 5.3.4.3.1, step (a).
- Raise jack to apply slight pressure on assembly.
- Remove mounting nuts and bolts from both sides of axle assembly.
- Carefully lower jack and assembly until wheels are on the ground and front axle tube clears tank mounts.

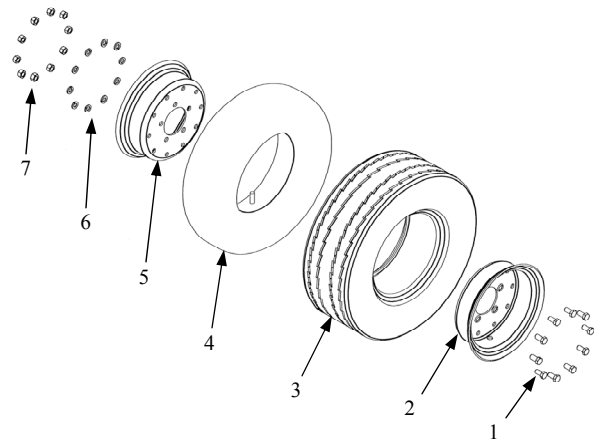

- |                       |                |
|-----------------------|----------------|
| 1. BOLTS              | 5. SPLIT RIM   |
| 2. SPLIT RIM FOR STEM | 6. LOCK WASHER |
| 3. TIRE               | 7. NUTS        |
| 4. INNER TUBE         |                |

**Figure 5-10. Wheel Assembly**

1. BRAKE HANDLE
2. BOLT
3. NUT
4. EQUALIZER NUT
5. EQUALIZER
6. LINKAGE
7. LINKAGE PIN

8. COTTER PIN
9. CABLE HOUSING (TYP)
10. BRAKE CABLE
11. CLEVIS
12. COTTER PIN
13. CLEVIS PIN
14. CABLE HOUSING NUT

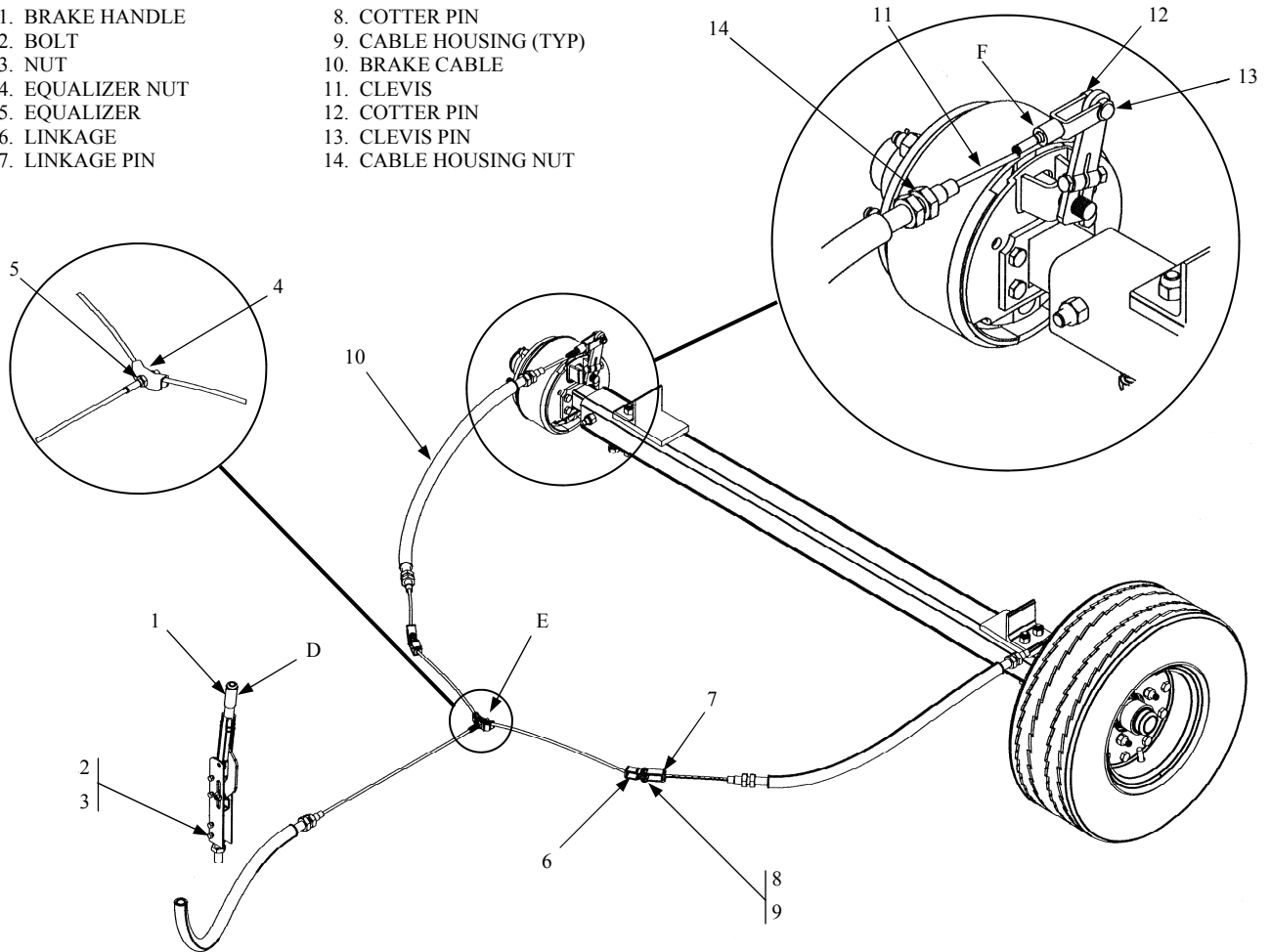

**Figure 5-11. Brake Handle And Cable Assembly**

**5.3.5 Wheel Assembly.** The Wheel assembly is a two-piece, split rim design. Use Figure 5-10 for the following maintenance steps.

- a. Remove wheel assembly as described in Paragraph 5.3.4.1 for the side needing repair.
- b. Release air pressure from the inner tube by depressing stem valve or by removing the stem valve.
- c. Remove nuts (7), lock washers (6), and bolts (1).
- d. Separate split-rims (2) and (5) from tire (3).
- e. Remove inner tube (4) from tire (3). Reassembly in reverse order. Ensure that inner tube stem is positioned through access hole in split-rim.
- f. Torque nuts (7) to 150-foot-pounds before applying air pressure to wheel.

**5.3.6 Plumbing Assembly.** The Plumbing Assembly is located at the rear of the unit. The assembly consists of a fuel pump (See Paragraph 5.3.6.1), a fuel meter (See Paragraph 5.3.6.2), a filter housing (See Paragraph 5.3.6.3), a selection valve (See Paragraph 5.3.6.4), a hose reel (See Paragraph 5.3.6.5), and several plumbing lines, hoses, and other plumbing items (See Paragraph 5.3.6.6). Paragraph 5.3.6.7 describes how to change the fuel filter element. Use Figure 5-12 for the maintenance steps described in 5.3.6.1 through 5.3.6.5.

**WARNING**

Drain all flammable liquids from the tank and plumbing system before performing any of the steps described here. Flammable liquids and vapors pose a fire danger that could result in serious injury or death.

**WARNING**

Disconnect all electrical connections to the unit (batteries, battery charger, tow vehicle) before performing any of the steps described here. Flammable liquids and vapors can be ignited by accidental electrical arcs. Serious injury or death could result.

**5.3.6.1 Fuel Pump.** The fuel pump (8) is removed by following the maintenance steps described below.

- a. Remove electrical leads from pump motor. The cover plat is located rearward of the pump motor and the conduit is located forward the pump motor.
- b. Remove the four bolts connecting the fuel meter (13) to the pump-to-meter line (14).
- c. Remove the four bolts at the bottom of the fuel pump that attach the pump body to the pump inlet/pump strainer housing.
- d. Remove pump noting presence of gasket and pump strainer.
- e. Install in reverse order.

**5.3.6.2 Fuel Meter.** The fuel meter (13) is removed by following the maintenance steps described below.

- a. Remove the four bolts connecting the fuel meter (13) to the pump-to-meter line (14). Note presence of O-ring.

- b. Remove the four bolts connecting the fuel meter (13) to the meter-to-filter line (12). Note presence of O-ring.
- c. Install in reverse order

**5.3.6.3 Filter Housing.** The filter housing (10) is removed by following the maintenance steps described below.

- a. Remove fuel meter (13) as described in Paragraph 5.3.6.2.
- b. Using a pipe wrench, remove filter housing (10) from method selection valve (15).
- c. Remove plumbing lines from filter housing (10) using a pipe wrench and a bench vise.
- d. Install in reverse order noting the orientation of the meter-to-filter line (12).

**5.3.6.4 Selection Valve.** The fuel service selection valve (15) is removed by the following maintenance steps described below.

- a. Remove fuel meter (13) as described in Paragraph 5.3.6.2.
- b. Remove the valve-to-reel line (16).
- c. Remove the valve-to-strainer (3) Victaulic fitting at the elbow next to selection valve.
- d. Remove the tank-to-valve line (5) Victaulic fitting at the elbow next to the selection valve.
- e. Remove the U-bolt (not shown) that secures the remaining assembly to the frame.
- f. Using a pipe wrench and a bench vise, remove remaining components.
- g. Install in reverse order.

**5.3.6.5 Hose Reel.** The hose reel (1) is removed by the following maintenance steps described below.

- a. Remove all items connected to mounting bracket (19) and remove bracket.
- b. Remove valve-to-reel line (16).
- c. Remove the four bolts connecting the hose reel (1) to the frame.
- d. Install in reverse order.

**5.3.6.6 Other Plumbing Assembly Items.** Other plumbing assembly items include the Pressure Relief Valve (See Paragraph 5.3.6.6.1), the Y-Strainer (See Paragraph 5.3.6.6.1) and several hard and soft plumbing lines (See Paragraph 5.3.6.6.1)

1. HOSE REEL
2. TO-TANK HOSE LINE
3. VALVE-TO-STRAINER LINE
4. PRESSURE RELIEF LINE
5. TANK-TO-VALVE LINE
6. Y-STRAINER
7. STRAINER-TO-PUMP LINE
8. FUEL PUMP
9. PRV SWIVEL
10. FILTER HOUSING
11. PRESSURE RELIEF VALVE
12. METER-TO-FILTER LINE
13. FUEL METER
14. PUMP-TO-METER LINE
15. METHOD SELECTION VALVE
16. VALVE-TO-REEL LINE
17. FUEL HOSE
18. FUEL HOSE QD FITTING
19. MOUNTING BRACKET
20. FUELING NOZZLE

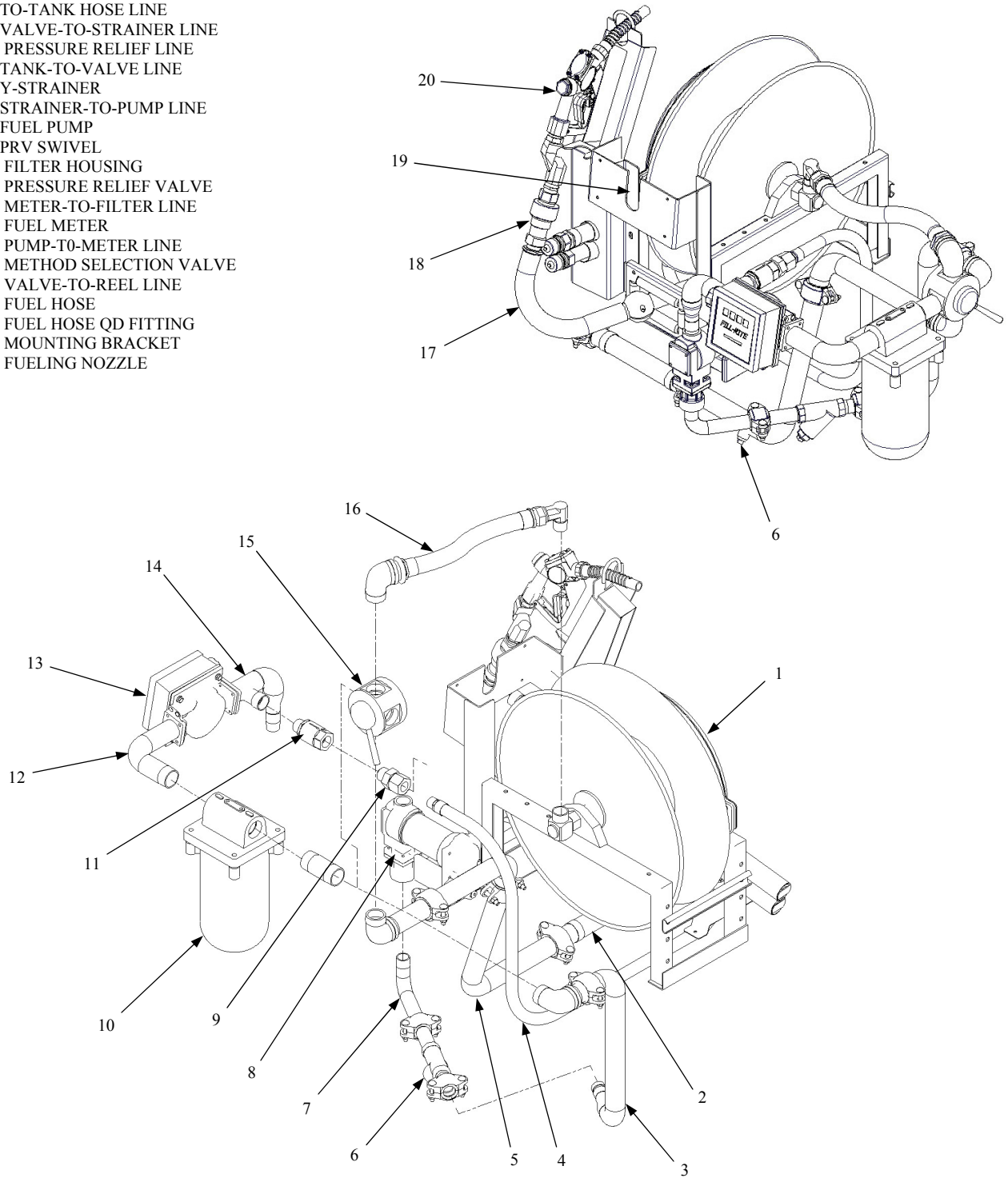

**Figure 5-12. Plumbing Assembly**

5.3.6.6.1 **Pressure Relief Valve.** The pressure relief valve (11) is removed by following the maintenance steps described below.

- a. Remove pressure relief line (4) at PRV swivel (9).
- b. Remove pressure relief valve (11) from the pump-to-meter line (14). Note the direction of flow.
- c. Install in reverse order.

5.3.6.6.2 **Y-Strainer.** The Y-strainer (6) is removed by following the maintenance steps described below.

- a. Remove the Victaulic fitting on either side of the Y-strainer (6).
- b. Remove. Note the direction of flow.
- c. Install in reverse order.

5.3.6.6.3 **Hard and Soft Plumbing Lines.** Both hard (rigid) and soft (flexible) plumbing lines are used. Both types are connected by grooved Victaulic fittings, bolted flanged fittings with gasket, or threaded pipe fittings. Remove plumbing lines as required to perform the specific maintenance activity.

5.3.6.7 **Fuel Filter Element.** The fuel filter element should be replaced whenever fuel flow is restricted or at least once per year. The following steps describe how to replace the fuel filter. See Figure 5-13.

- a. Drain filter housing by opening the top and bottom petcock valves.
- b. Remove the four bolts that secure the filter canister to the filter housing.
- c. Pull downward on the filter element.
- d. Replace O-ring (not shown.)
- e. Install new filter element in reverse order.
- f. Close bottom petcock valve.
- g. Jog pump to purge air.
- h. Close top petcock valve.

### 5.3.7 ELECTRICAL SYSTEM

The electrical system consists of a Main Electrical Panel (See Paragraph 5.3.7.1) that distributes power to the Fuel Pump and Work Lights as required, an Operator Console (See Paragraph 5.3.7.2) that controls the operational functions of the equipment, and a Charging System (See Paragraph 5.3.7.3)

5.3.7.1 **Main Electrical Panel.** The main electrical panel contains all the power distribution wiring and electrical control relays, diodes, and solenoids. The 120-VAC battery charger and system circuit breakers are also located here. Refer to Chapter 7 for the Illustrated Parts Breakdown for maintenance items.

5.3.7.2 **Operator Console.** The only maintenance activity for the operator console is to change out indicator lights.

- a. Identify the indicator light that needs to be removed.
- b. Rotate lens approximately 10 - 15 degrees CCW and remove.
- c. Using approximately size tool, remove circular diffuser disk (plastic) from housing.
- d. Remove light bulb.
- e. Install in reverse order.

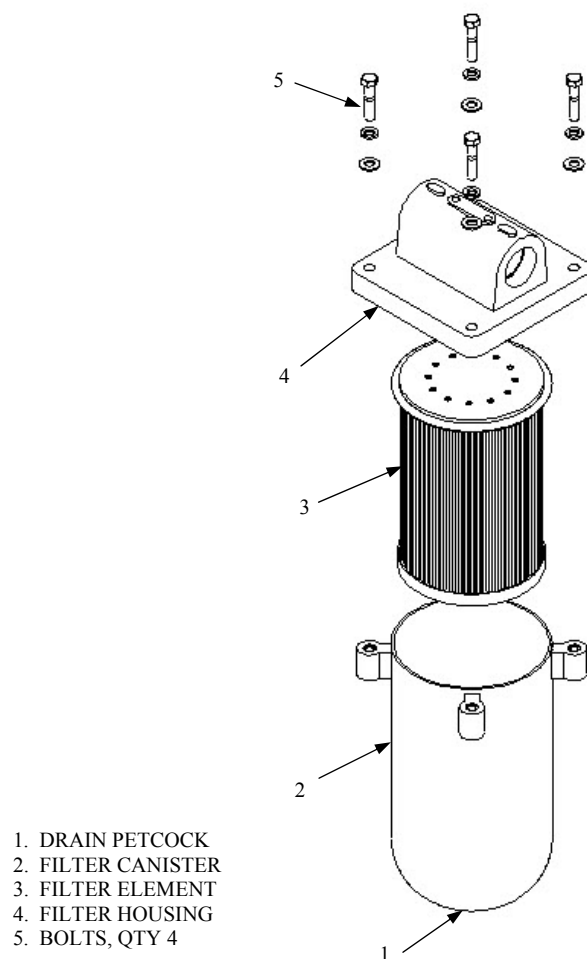

**Figure 5-13. Fuel Filter**

**5.3.7.3 Charging System.** The Charging System has two methods of charging. The first is by the on-board battery charger (See Paragraph 5.3.7.3.1.) The second is by the tow vehicle when the 7-pin trailer connector is connected and properly wired (See Paragraph 5.3.5.7.2.)

**5.3.7.3.2 Tow Vehicle Charging.** The on-board batteries can also be charged by the tow vehicle. The 7-pin trailer connection at the tow vehicle must be wired properly. See Chapter 6 for the recommended wire schematic.

**NOTE**

The batteries will charge from any of the following:

- The tow vehicle, when connected, ONLY if the battery switch is OFF.
- The battery charger, when plugged in, whether or not the battery switch is ON or OFF.
- When the fuel pump is running, the batteries WILL NOT charge from any source.

**5.3.7.3.1 On-board Battery Charger.** The on-board battery charger requires no maintenance. Incoming voltage is factory set to 120-VAC, 60-Hz. Incoming voltage can be field changed to 230-VAC, 50-Hz. Consult Spokane Industries at the contact number in the front of the manual for instructions on changing the voltage or any other battery charger concerns.

**5.4 TROUBLESHOOTING.**

The trouble shooting paragraphs and tables outline probable causes to typical problems. Operational steps, such as “open valve,” are not included in solutions. Verify that the operational steps outlined in Chapter 4 are being followed correctly before trouble shooting suspected problems. Tables 5-1 through 5-6 contain the trouble shooting guides.

**5.5 PREVENTIVE MAINTENANCE.**

The HANDIFUELER has been designed to require very little preventive maintenance. Materials such as stainless steel, 6061 aluminum, and oil-impregnated bronze bushings have been used in the design to minimize maintenance and repair requirements. Preventive Maintenance information can be found in Table 5-7.

**Table 5-1. Troubleshooting - General Tank**

Problem	Probable Cause	Corrective Action
Threaded connection leaking or weeping	Loose fitting, bad seal, damaged fitting.	Fix condition. See Paragraph 5.3.1.
Valve leaking, weeping, or inoperable	Internal damage to valve’s ball, stem, or seat.	Replace valve. See Paragraph 5.3.1.

**Table 5-2. Troubleshooting - Manway Assembly**

Problem	Probable Cause	Corrective Action
Manway Assembly won’t seal	A) Manway Assembly is out of adjustment.	A) Adjust Manway Assembly. See Paragraph 5.3.2.2.
	B) Seal is damaged.	B) Replace Manway Seal. See Paragraph 5.3.2.1.

**Table 5-3. Troubleshooting - Front Undercarriage**

Problem	Probable Cause	Corrective Action
Tow bar won't lock in the up-right position	Tow latch spring damaged or missing.	Inspect and replace as needed. See Paragraph 5.3.3.4.
Wheels won't steer properly	A) Steering Arm Assembly is damaged.	A) Inspect and repair as needed. See Paragraph 5.3.3.5.
	B) Tie Rod Assembly is damaged or misadjusted.	B) Inspect, repair, and adjust as needed. See Paragraph 5.3.3.6.
Wheels wobble or drag while rolling	Wheel bearings damaged or loose.	Inspect and repair as needed See Paragraph 5.3.3.2.

**Table 5-4. Troubleshooting - Rear Undercarriage/Brakes**

Problem	Probable Cause	Corrective Action
Wheels wobble or drag while rolling	Wheel bearings damaged or loose.	Inspect and repair as needed. See Paragraph 5.3.4.2.
Brakes do not properly secure unit while engaged	A) Brakes are out of adjustment.	A) Adjust brakes. See Paragraph 5.3.4.3.3.
	B) Parking Brake Assembly is damaged or missing.	B) Inspect and repair as needed. See Paragraph 5.3.4.3.

**Table 5-5. Troubleshooting - Plumbing System**

Problem	Probable Cause	Corrective Action
Pump won't start	Electrical system not energized	See Table 5-6 for Electrical system.
Pump runs, but no fuel flows from nozzle when fueling or is extracted when extracting fuel.	A) Selection Valve in DEFUEL position	A) Position Selection Valve to FUEL position.
	B) Tank is empty (fueling only)	B) Fill tank with fuel (fueling only.)
	C) Fuel Filter needs to be replaced	C) Replace fuel filter. See Paragraph 5.3.6.7.
	D) Y-strainer is blocked	D) See Paragraph 5.3.6.6.2
	E) Fuel pump broken	E) Replace fuel pump. See Paragraph 5.3.6.1
System seems to leak	Leaking or weeping fitting	Fix fitting. See Paragraph 5.3.1.

**Table 5-5. Troubleshooting - Plumbing System Continued**

Problem	Probable Cause	Corrective Action
Fuel Meter doesn't read correctly	A) Fuel meter can't accurately meter flow in Fuel Extraction operation because of air pockets	A) Don't refer to fuel meter for Fuel Extraction operations
	B) Broken fuel meter	B) See Paragraph 5.3.6.2
Hose reel won't retract	Malfunctioning return mechanism	Consult Spokane Industries.

**Table 5-6. Troubleshooting - Electrical System**

Problem	Probable Cause	Corrective Action
No power available	A) Battery switch OFF	A) Turn on battery switch. See Figure 4-4
	B) Batteries not charged	B) Charge batteries with on-board 120-VAC charger
	C) Circuit breaker(s) tripped	C) Reset circuit breakers. See Figure 4-4
Batteries won't charge	A) Mal-functioning charging system	A) See Paragraph 5.3.7.3
	B) Bad batteries	B) Replace batteries.

**Table 5-7. Preventive Maintenance**

Item	Interval	Action
Brakes	Quarterly	Check Brakes for proper adjustment. Adjust as needed. See Paragraph 5.3.4.3.3 for maintenance instructions.
Tank Weldment	Yearly	Inspect inner tank welds for cracks. Check baffles for cracks. Check outer tank welds for cracks. Remove plug from outer tank test fitting and inspect for evidence of fuel.
Wheel Bearings	Yearly	Disassemble and pack wheel bearings with grease. Inspect for damage and replace components as needs. See Paragraphs 5.3.3.2 and 5.3.4.2 for maintenance instructions.

**Table 5-8. Daily Pre-operation Inspection Check Sheet**

Item	What to Inspect
Manway Seal	Inspect Manway Seal for tears, cracks, and compression damage. Replace if needed. See Paragraph 5.3.2 for maintenance instructions.
Wheels/Tires	Inspect for tire damage and proper tire pressure. Ensure that no lug nuts are missing or loose.
Brakes	Inspect for proper function and adjustment.
Tow Bar	Inspect for damage such as cracks in welds and missing attachment pin and retaining clip.
Tank	Inspect for leaks and obvious damage. Ensure Manway Assembly closes and latches properly. Check undercarriage mounting hardware for loose and/or missing components.
Hoses	Inspect for damage such as cracks and rub spots. Ensure fittings ends are operational.
Ground Reel	Inspect for function. Ensure cable end is securely fastened to cable.
Valves	Inspect for function.
Fuel Filter	Drain water from filter canister.
Low-point Drain	Drain water from tank low-point sump.

# CHAPTER 6 DIAGRAMS

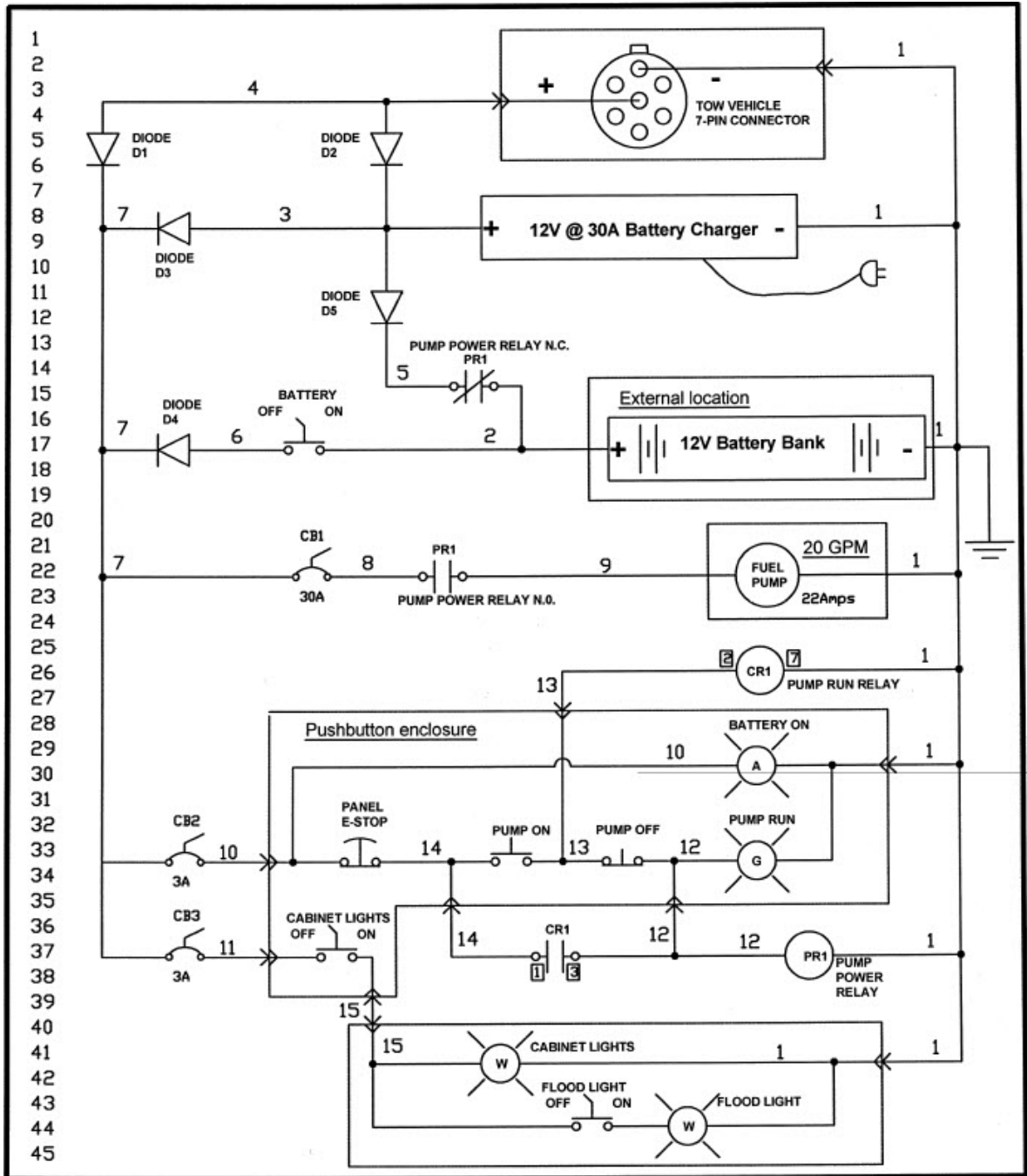

Figure 6-1. Wiring Schematic

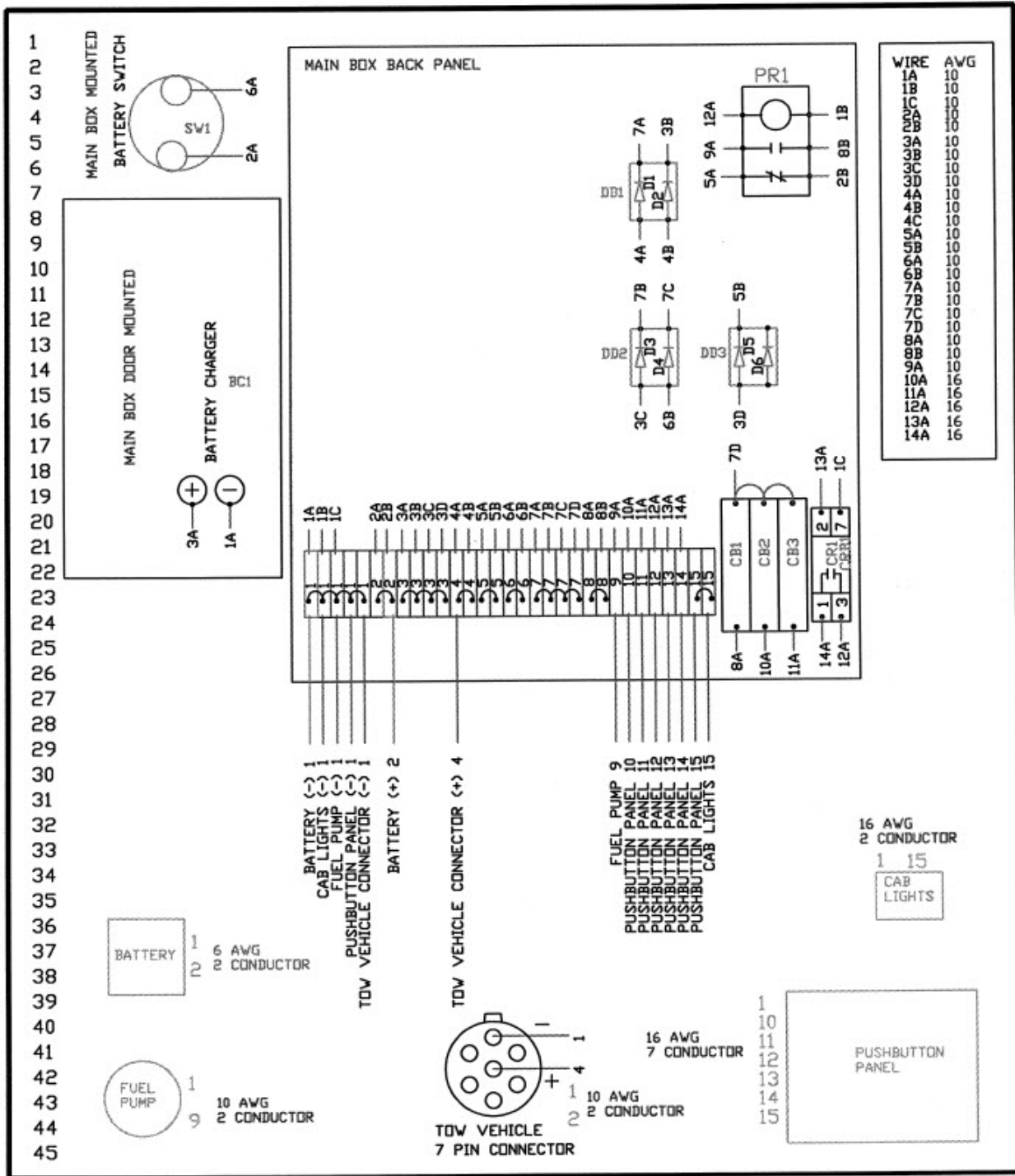

Figure 6-2. Wiring Schematic Continued

# CHAPTER 7

## ILLUSTRATED PARTS BREAKDOWN

### SECTION I FOREWORD

#### 7.1 INTRODUCTION.

This Illustrated Parts Breakdown (IPB) is designed to assist supply and maintenance personnel in requisitioning, storing, issuing, an identifying parts, and to illustrate assembly and disassembly relationships. It is not intended to be used as an authority for procedures of disassembly or reassembly. Maintenance or repair should be performed by authorized personnel using the applicable maintenance instructions contained in Chapter 5 of this publication. Illustrations at the end of this section show how to use the IPB.

#### 7.2 MODELS COVERED.

**7.2.1 Equipment Covered.** This IPB lists and describes items necessary for support of the HANDIFUELER™ 400 and 600 gallon systems; part numbers AGE400S-12VDC and AGE600S-12VDC respectively; manufactured by Spokane Industries Inc. of Spokane Valley, Washington State, USA.

**7.2.2 Accessories Covered.** This IPB also lists and describes the accessories necessary for support of the HANDIFUELER™ 400 and 600 gallon systems; part numbers AGE400S-12VDC and AGE600S-12VDC respectively; manufactured by Spokane Industries Inc. of Spokane Valley, Washington State, USA.

#### 7.3 MAINTENANCE PARTS LIST (MPL).

The MPL is divided into figures by main equipment groups and/or assemblies. Each group or assembly is keyed to a related illustration by figure and index number. They are then broken down into assemblies, modules and detailed parts. The relation of each part to its next higher assembly and/or group is shown either by indentation or by figure cross-reference notes. The MPL is divided into seven columns as described below.

**7.3.1 Figure and Index Number Column.** This column provides the figure and index numbers used to key a part or assembly listed in the MPL to its location in an illustration. The figure number precedes the first index number in each

listing and the first index number on each page of a multi-page listing. Index numbers are listed in sequence.

**7.3.2 Part Number Column.** Part numbers may be specification control numbers, vendor part numbers or commercial part numbers. Part numbers, including dash numbers, are assigned to each listed part in accordance with current industry engineering practices. Parts which are indexed in the MPL, but not shown on the illustration, have a dash (-) preceding the index number.

**7.3.3 Commercial and Government Entity (CAGE) Code Column.** Explanations of CAGE codes are contained in CAGE Cataloging Handbook H4/H8 and amendments thereto.

**7.3.4 Description Column.** The description column contains indenture, nomenclature and cross-reference information. The identifying noun is given first. Sizes, dimensions, materials, and tolerances are then indicated. If applicable, the appropriate numbers for types, models, specifications, specification control drawings, and source control drawings follow the nomenclature. When the drawing number for a part is different than the part number (excluding dash differences), the drawing number follows the description. References to other illustrations for information on detail parts or information on next higher assemblies (NHA) are given. Attaching parts are identified by the abbreviation (AP) following the description. Parts listed in the MPL are indented to indicate item relationship or NHA. Nomenclature of each assembly is followed in the list (except for attaching parts) by nomenclature of its component indented one column to the right. This indentation indicates relationship of component to assembly. To determine NHA of a part or assembly, note column in which the first word of nomenclature appears. First item directly above, which appears one column to the left (except for attaching parts), is the NHA.

Description

1234567

END ITEM, COMPONENT, MAJOR ASSEMBLY  
 . DETAIL PARTS FOR END ITEM  
 . COMPONENT, MAJOR ASSEMBLY  
 . ASSEMBLY  
 . Attaching parts for assembly (AP)  
 .. Detail parts for assembly  
 .. Subassemblies  
 .. Attaching parts for subassemblies (AP)  
 ... Detail parts for subassemblies  
 ... Attaching parts for sub-subassemblies (AP)  
 .... Detail parts for sub-subassemblies

**7.3.5 Units Per Assembly Column.** Quantities shown in this column represent units required for each detail part in an assembly, each assembly in the NHA, and each attaching part to attach one unit or one assembly. The abbreviation AR (as required) is used when quantity required must be determined when parts are installed. The abbreviation REF (reference) indicates that items has been previously listed under it NHA. The SEE FIGURE notation in description of item indicates figure and index numbers at which units per assembly can be determined.

**7.3.6 Usable On Code Column.** These codes indicate parts usage. Absence of a code indicates that the part is usable on all its NHAs. When required, Usable on Codes are defined in the MPL. MIL-PRF-38807C contains additional information about Usable on Codes.

**7.3.7 Source, Maintenance and Recoverability (SMR) Code Column.** SMR codes have not been assigned against any components at this time.

**7.3.8 Symbols Used in the MPL.** A dash (-) before an index number denotes a part which is not illustrated. A number sign (#) flush right of a part number indicates that detail parts are listed in a separate manual. An asterisk (\*) flush right of the part number means the marking is to be requisitioned in accordance with AFI 37-162. The letter "F" before the figure number means "follows" and is used when an assembly or part has not been assigned an index number, and the figure and index number of the preceding part has been used.

**7.3.9 Multi-sheet Illustrations.** If used, the sheet number follows the index number and is separated by a slash (/). If an indexed item is on more than one sheet of an illustration, the first and last sheet numbers on which the item appears are given.

**7.4 NUMERICAL INDEX (NI).**

If applicable, an NI is provided which contains an alphanumeric listing of all drawings and parts listed in the MPL (including model and type numbers for components not assigned part numbers).

**7.4.1 Part Number Column.** Part numbers begin at the extreme left and continue from left to right, one position at a time. For the first character of the part number, the letters A through N and P through Z take precedence over the numerals, 0 through 9 (alphabetic Os are considered numeric zeros). For the second and succeeding characters of a part number, precedence is as follows: (1) diagonal, (2) period, (3) dash, (4) letters A through N and P through Z, and (5) numerals 0 through 9. Refer to MIL-PRF-38807C for detailed information about part numbers and their usage in the MPL.

**7.4.2 Figure and Index Number Column.** This column contains the figure and index number for all parts listed.

**7.5 REFERENCE DESIGNATION INDEX (RDI).**

If used, the RDI follows the NI and contains a listing of the reference designations that are assigned to the parts list of this IPB. Reference designations appear on electrical and electronic diagrams and are used to correlate graphic symbols show thereon with parts lists, descriptions, and instructions concerning the diagrams.

**7.6 USABLE ON CODES.**

When two or more assemblies are listed in the same parts list, a code letter (A, B, etc.) is assigned to each main assembly. All subcomponents, peculiar to a particular assembly, are identified by the same code letter as the main assembly. If parts are common to all assemblies covered, the Usable on Code column is left blank. Usable on Codes are further explained in MIL-PRF-38807C.

7.7 SOURCE, MAINTENANCE, AND RECOVERABILITY (SMR) CODES AND UNIQUE SOURCE CODES.

Information about Joint Military Services Uniform SMR codes and unique source codes can be found in TO 00-25-195.

7.8 COMMERCIAL AND GOVERNMENT ENTITY (CAGE).

Information about CAGE codes can be found in the H4/H8 Cataloging Handbook and its amendments.

7.9 PARTS STANDARDIZATION.

Authority for use of a part number different than the part number listed in the IPB is established by the Department of Defense (DoD) Interchangeability and Substitution (I&S) Program. Refer to the DO43B Master Item Identification Base for Air Force I&S information. The maintenance technician has final responsibility and authority for determining acceptability of substitute parts. Authority for use of a part number different than the part number listed in this IPB shall be approved in writing by the cognizant engineering agency responsible for configuration control.

7.10 LIST OF MANUFACTURER'S CODES (CAGE).

Following is a list of CAGE codes with name and addresses that corresponds to each code. The codes are in accordance with Cataloging Handbook H4/H8. Codes are listed in numerical order, followed by an alphabetical listing of manufacturers for which no code has been assigned. Government



# HOW TO USE THE ILLUSTRATED PARTS BREAKDOWN IF PART NUMBER IS NOT KNOWN

IF PART NUMBER IS NOT KNOWN.... **Do This**

Chapter	Page	Chapter	Page
1 INTRODUCTION	1-1	2 MAINTENANCE PARTS LIST	2-1
1.1 General	1-1	1 Processor Interface, J-6183/U	2-1
1.1.1 Parts Standardization	1-1	2 Bus (553, A13, A21, A22)	2-8
1.2 Drawing Number	1-1	3 Circuit Card Assembly, One Magnetics	2-12
1.3 Nuclear Hardware Design Features	1-1	4 RAM, A14, A20	2-12
1.4 Electrical Discharge (ESD)	1-1	5 Circuit Card Assembly, Dual Bus	2-16
1.5 Safety	1-1	6 Processor 286, A15	2-16
1.5.1 Maintenance Part List	1-1	7 Wiring Harness Assembly, W1	2-22
1.5.2 Figure and Index Number	1-1	8 Dual W3, W4 into W3A, W3B	2-22
1.5.3 Part Number	1-2	9 Assembly W19, W20	2-22
1.5.4 Commercial and Government Entity (CAGE)	1-2	10 Cable Assembly, W4 into W9	2-22
1.5.5 Description	1-2	11 Backplane Assembly, A28	2-30
1.5.6 Date Per Assembly	1-2	12 Processor Connector, CP30P01	2-33
1.5.7 Usable On Code	1-2	13 Wiring Harness Assembly, W3, W4	2-39
1.5.8 Storage, Maintenance, and Recoverability (SMR) Codes	1-2	14 Backplane Assembly, A28	2-32
1.6 Nomenclature Index	1-2	15 NUMERICAL INDEX	3-1
1.6.1 Part Number	1-2	16 REFERENCE DESIGNATION INDEX	4-1
1.6.2 Figure and Index Number	1-2		
1.7 Reference Designation Index	1-3		
1.7.1 Reference Designation Column	1-3		
1.7.2 Figure and Index Number	1-3		
1.8 Symbols and Abbreviations	1-3		
1.9 Cross-Index Systems	1-3		
1.10 Similar Assemblies	1-3		
1.11 Related Technical Manuals	1-3		

1. Determine in which unit the part is located. Turn to the TABLE OF CONTENTS. From this list, select the illustration most likely to contain the desired part.

2. Refer to page number of the illustration selected from TABLE OF CONTENTS. Locate the desired part on the illustration. Note index number.

3. Refer to corresponding MAINTENANCE PARTS LIST. Locate the index number selected from the illustration for part number, nomenclature, etc.

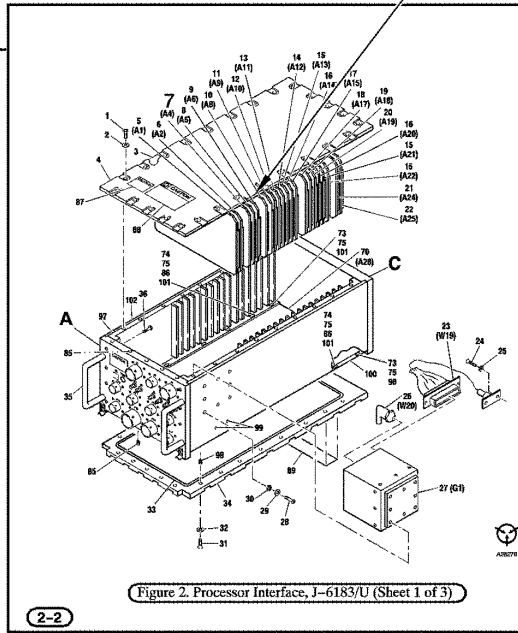

FIGURE AND INDEX	PART NUMBER	QTY	DESCRIPTION	UNITS PER ASSY	USABILITY CODE	SR# CODE
2-	4000-0800-11	32562	**ESD** INTERFACE, Processor, J-6183/U	1		PACD0
1	4000-0801-03	32562	POWER SUPPLY, Access, top	1		PAF22
2	4000-0802-03	32562	WASHER CAP	24		PAF22
3	4000-0803-03	32562	WASHER CAP	24		PAF22
4	4000-0804-03	32562	WASHER CAP	24		PAF22
5	4000-0805-03	32562	WASHER CAP	24		PAF22
6	4000-0806-03	32562	WASHER CAP	24		PAF22
7	4000-0810-05	32562	**ESD** CIRCUIT CARD ASSY, IF	1		PAF22
8	4000-0815-03	32562	**ESD** CIRCUIT CARD ASSY, CP	1		PAF22
9	4000-0816-03	32562	**ESD** CIRCUIT CARD ASSY, IF	1		PAF22
10	4000-0817-03	32562	**ESD** CIRCUIT CARD ASSY, CP	1		PAF22
11	4000-0818-03	32562	**ESD** CIRCUIT CARD ASSY, CP	1		PAF22
12	4000-0819-03	32562	**ESD** CIRCUIT CARD ASSY, CP	1		PAF22
13	4000-0820-03	32562	**ESD** CIRCUIT CARD ASSY, CP	1		PAF22
14	4000-0821-03	32562	**ESD** CIRCUIT CARD ASSY, CP	1		PAF22
15	4000-0822-03	32562	**ESD** CIRCUIT CARD ASSY, CP	1		PAF22
16	4000-0823-03	32562	**ESD** CIRCUIT CARD ASSY, CP	1		PAF22
17	4000-0824-03	32562	**ESD** CIRCUIT CARD ASSY, CP	1		PAF22
18	4000-0825-03	32562	**ESD** CIRCUIT CARD ASSY, CP	1		PAF22
19	4000-0826-03	32562	**ESD** CIRCUIT CARD ASSY, CP	1		PAF22
20	4000-0827-03	32562	**ESD** CIRCUIT CARD ASSY, CP	1		PAF22
21	4000-0828-03	32562	**ESD** CIRCUIT CARD ASSY, CP	1		PAF22
22	4000-0829-03	32562	**ESD** CIRCUIT CARD ASSY, CP	1		PAF22
23	4000-0830-03	32562	**ESD** CIRCUIT CARD ASSY, CP	1		PAF22
24	4000-0831-03	32562	**ESD** CIRCUIT CARD ASSY, CP	1		PAF22
25	4000-0832-03	32562	**ESD** CIRCUIT CARD ASSY, CP	1		PAF22
26	4000-0833-03	32562	**ESD** CIRCUIT CARD ASSY, CP	1		PAF22

## SECTION II MAINTENANCE PARTS LIST

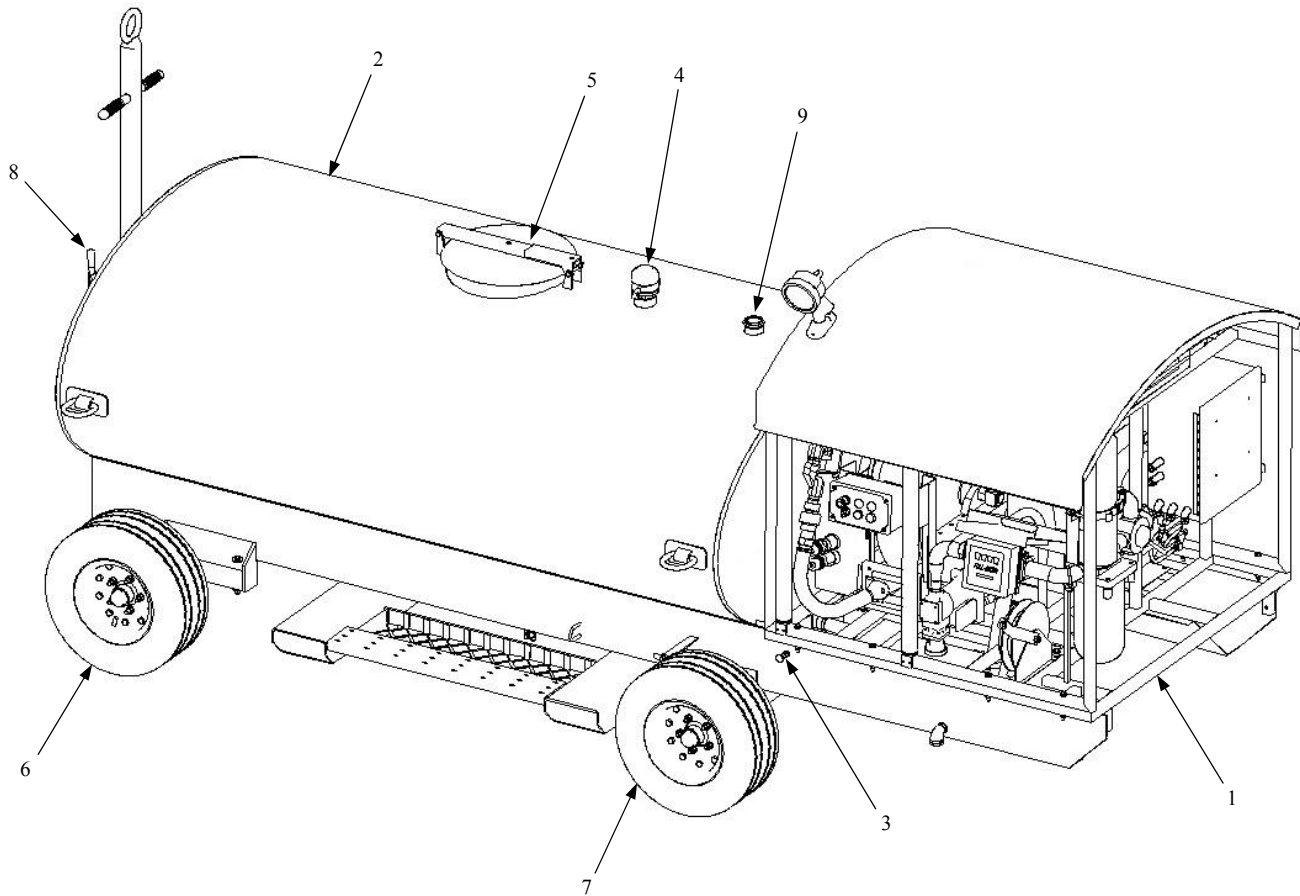
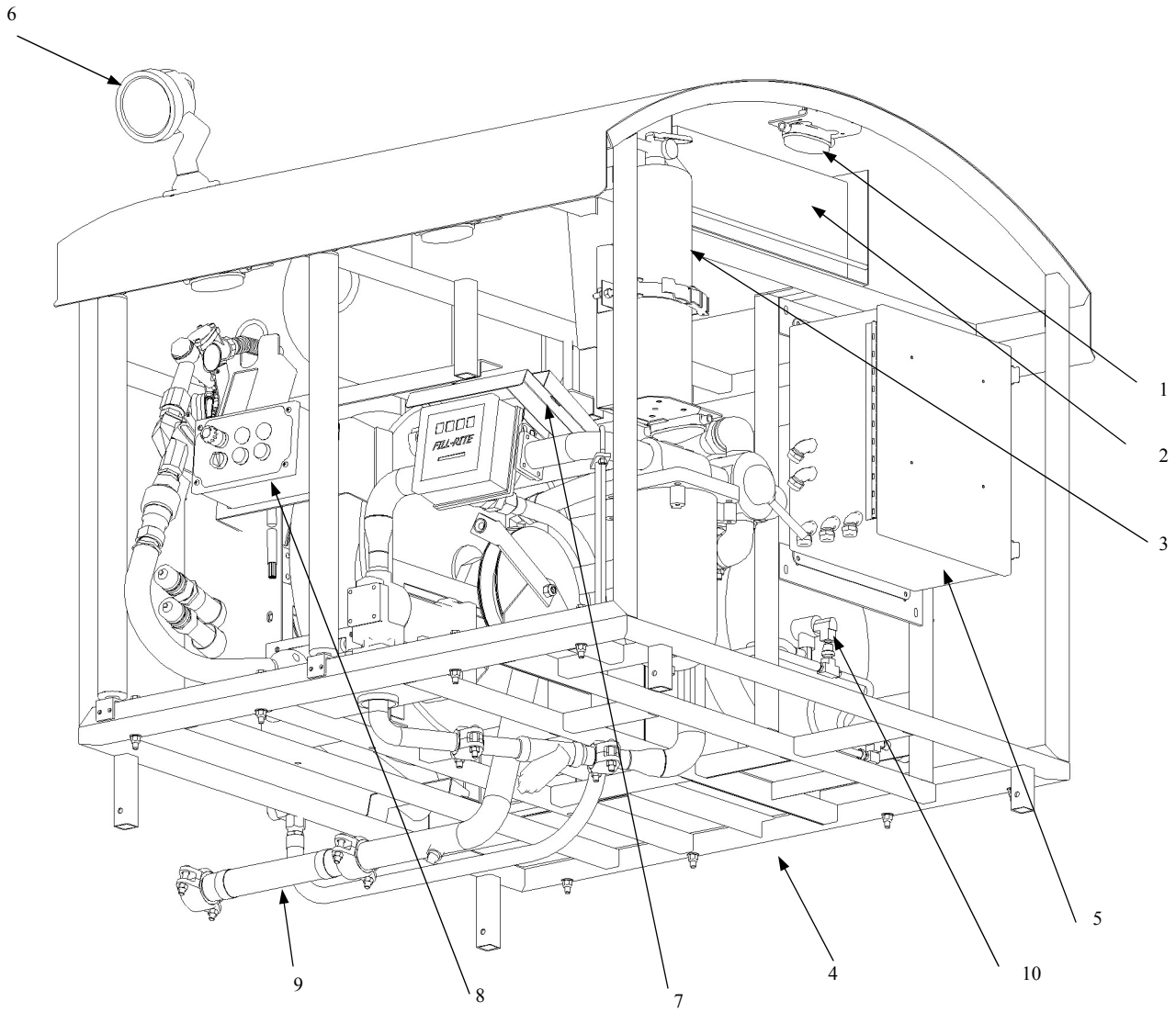

Figure 7-1. Overall Assembly

FIGURE & INDEX / SHEET NO.	PART NUMBER	CAGE	DESCRIPTION 1 2 3 4 5 6 7	UNITS PER ASSY	USABLE ON CODE	SMR CODE
7-1			OVERALL ASSEMBLY			
	98-2002-XXX	66144	AGE400S-12VDC (400 GALLON).....	1		
	98-2003-XXX	66144	AGE600S-12VDC (600 GALLON).....	1		
1	25-0001	66144	. PUMP MODULE, (SEE FIG. 7-2) .....	1		
-2	07-9014	66144	. TANK WELDMENT, AGE400S.....	1	A	
2	07-9015	66144	. TANK WELDMENT, AGE600S.....	1	B	
3	04-0468	66144	. LOW-POINT DRAIN CABLE .....	1		
4	04-01545	66144	. FILL/VENT PORT .....	1		
5	08-10251	66144	. MANWAY ASSEMBLY, (SEE FIG. 7-4) .....	1		
6	08-1018	66144	. FRONT UNDERCARRIAGE ASSY (SEE FIG. 7-5) .....	1		
7	08-10301	66144	. REAR UNDERCARRIAGE ASSY (SEE FIG. 7-6).....	1		
8	08-2502	66144	. PARKING BRAKE ASSEMBLY (400/600).....	1		
-9	04-8006	66144	. LEVEL GAUGE, 400 GALLON SIZES.....	1	A	
9	04-8007	66144	. LEVEL GAUGE, 600 GALLON SIZES.....	1	B	
-10	06-8002	66144	. DECAL KIT .....	1		
-11	06-1003	66144	. . "CAUTION, BRAKE MUST BE".....	1		
-12	06-1004	66144	. . "WARNING, GROUNDS MUST" .....	2		
-13	06-1006	66144	. . "DANGER NO SMOKING".....	2		
-14	06-1007	66144	. . "NOTICE, READ INSTRUCTIONS".....	1		
-15	06-1008	66144	. . "MAXIMUM TOWING SPEED" .....	1		
-16	06-7012	66144	. . REFLECTIVE TAPE, White .....	13		
-17	06-7020	66144	. . SI LOGO, Small .....	2		
-18	06-7027	66144	. . "LOW POINT DRAIN" .....	1		
-19	06-7031	66144	. . "SPILL RESPONSE KIT" .....	1		
-20	06-7048	66144	. . "RECLAIMED JP-8" .....	2		
-21	06-7053	66144	. . "FILTER CHANGED" .....	1		
-22	06-7054	66144	. . "DO NOT PRESSURIZE" .....	1		
-23	06-7055	66144	. . SI LOGO, Large .....	1		
-24	06-7056	66144	. . "FUEL/DEFUEL" .....	1		
-25	06-7057	66144	. . "WARNING, PRIOR TO DEFUEL" .....	1		
-26	06-7058	66144	. . "FUEL LOG" .....	1		
-27	06-7059	66144	. . "FLUID STOWAGE" .....	1		
-28	06-7060	66144	. . "TIRE SERVICE" .....	1		
-29	06-7061	66144	. . "CAUTION, PUMP FAILURE" .....	1		
-30	06-7062	66144	. . "FUEL FILL SERVICE PORT" .....	1		
-31	06-7067	66144	. . HANDIFUELER .....	1		
-32	06-7068	66144	. . "TIRE PRESSURE - 90PSI" .....	4		
-33	06-7069	66144	. . "PARKING BRAKE ONLY" .....	1		
-34	06-10025	66144	. . "CAUTION . . . WELL VENT." .....	1		
-35	06-10026	66144	. . "CAUTION LIQUID LEVEL" .....	1		
-36	105-00004-D002	66144	. . "MAIN BATTERY SWITCH".....	1		
			USABLE ON CODES: A - Model No. AGE400S-12VDC B - Model No. AGE600S-12VDC			

- Not Illustrated



**Figure 7-2. Pump Module**

FIGURE & INDEX / SHEET NO.	PART NUMBER	CAGE	DESCRIPTION							UNITS PER ASSY	USABLE ON CODE	SMR CODE
			1	2	3	4	5	6	7			
7-2	25-0001	66144	PUMP MODULE .....							1		
1	04-0802	66144	. LIGHT, LED, 12VDC .....							4		
2	04-8025	66144	. SPILL CONTAINMENT KIT .....							1		
3	04-0702	66144	. FIRE EXTINGUISHER, 5# PURPLE K.....							1		
4	25-2511	66144	. FRAME .....							1		
5	15-00103	66144	. MAIN ELECTRICAL PANEL (SEE FIG 7-11).....							1		
6	04-0800	66144	. LIGHT, LED FLOOD.....							1		
7	12-00035	66144	. DOCUMENT HOLDER.....							1		
8	15-00110	66144	. OPERATOR CONSOLE (SEE FIG 7-12).....							1		
9	25-5003	66144	. PLUMBING ASSEMBLY (SEE FIG 7-10).....							1		
10	25-5020	66144	. PNEUMATIC ASSEMBLY (SEE FIG 7-3).....							1		

- Not Illustrated

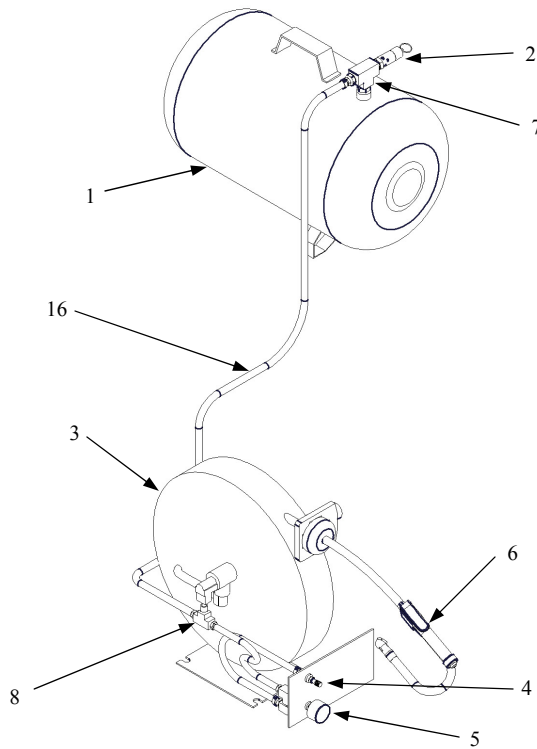

Figure 7-3. Pneumatic Assembly

FIGURE & INDEX / SHEET NO.	PART NUMBER	CAGE	DESCRIPTION							UNITS PER ASSY	USABLE ON CODE	SMR CODE
			1	2	3	4	5	6	7			
7-3	25-5020	66144	PNEUMATIC ASSEMBLY .....							1		
1	04-8032-2	66144	. TANK, 10 GALLON .....							1		
2	04-8034	66144	. PRESSURE RELIEF VALVE, .....							1		
3	04-8037	66144	. HOSE REEL .....							1		
4	04-8095	66144	. VALVE, SCHRADER .....							1		
5	04-9098	66144	. GAUGE, 0-100PSI .....							1		
6	04-8099	66144	. TIRE INFLATOR .....							1		
7	03-100584	66144	. TEE, 1/2" .....							1		
8	03-11131	66144	. TEE, 1/4" .....							2		
-9	03-11133	66144	. HOSE BARB, 1/4" BY 1/4" .....							6		
-10	03-111334	66144	. HOSE BARB, 1/8" BY 1/4" .....							1		
-11	03-10690	66144	. NIPPLE, CLOSE, 1/4" .....							1		
-12	03-10693	66144	. NIPPLE, HEX, 1/4" BY 1/8" .....							1		
-13	03-10083	66144	. NIPPLE, HEX, 1/2" .....							1		
-14	03-10152	66144	. BUSHING, 1/2" BY 1/4" .....							1		
-15	03-11136	66144	. STREET ELBOW, 1/4" .....							1		
16	06-2700	66144	. HOSE, 1/4" (U/M = FEET) .....							8		

- Not Illustrated

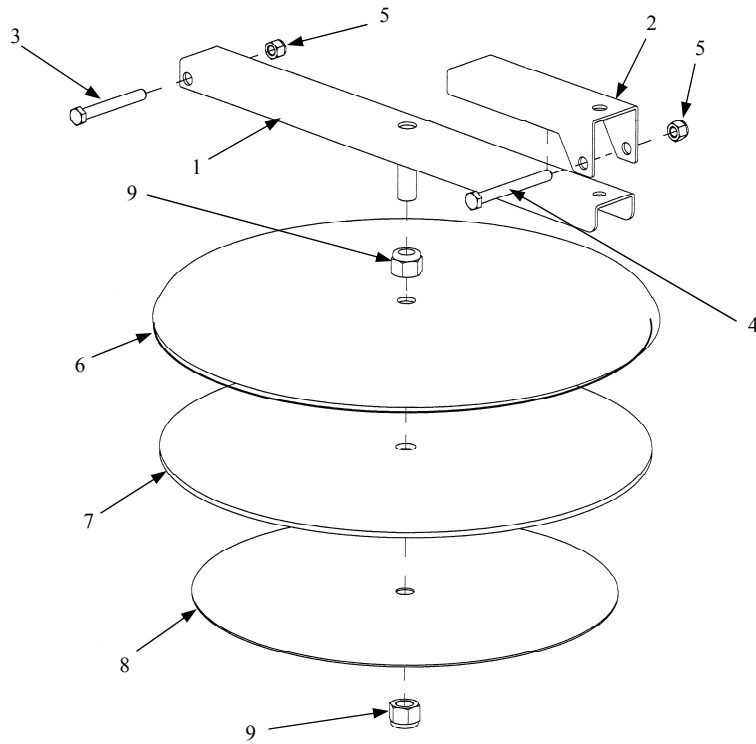
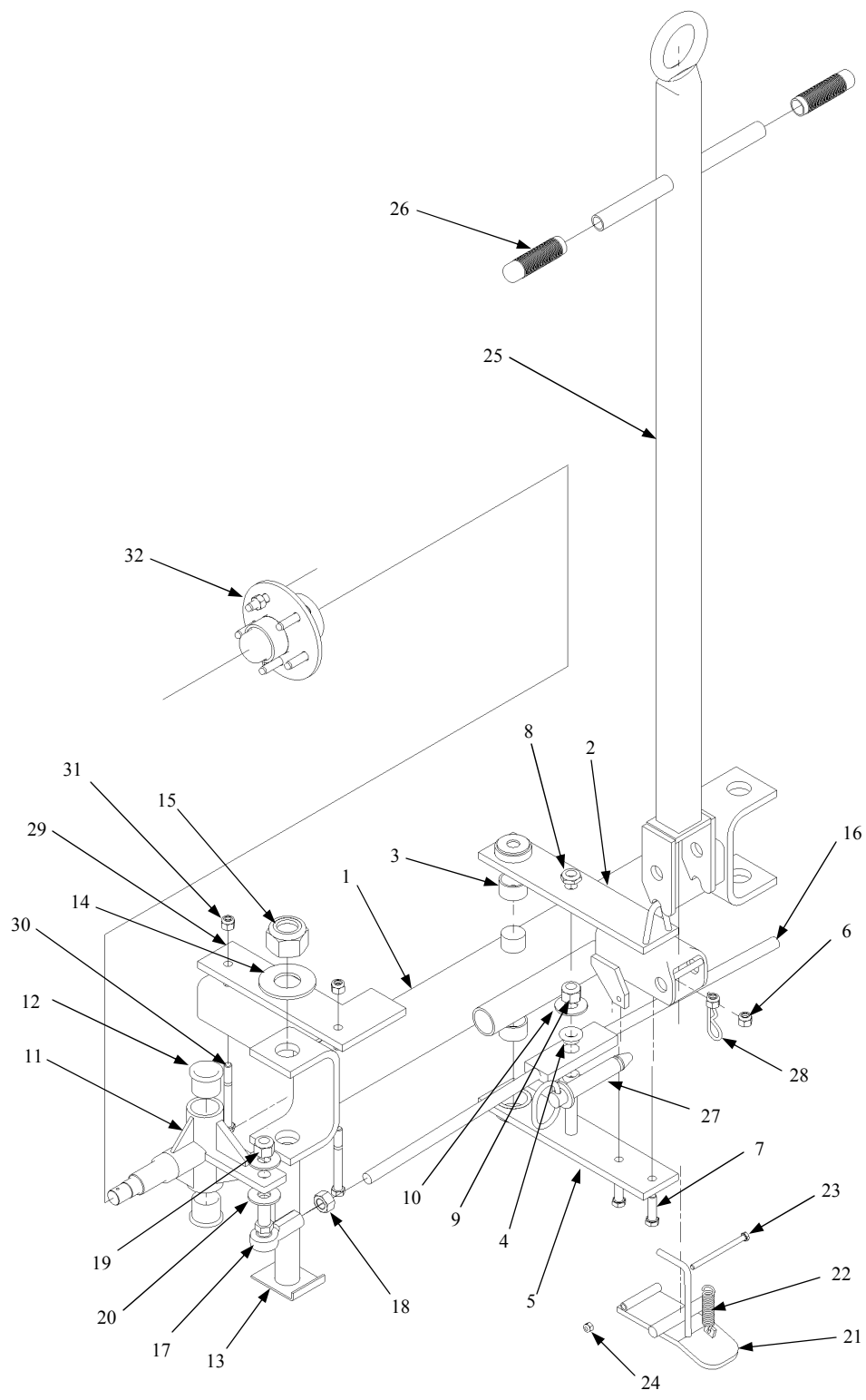

Figure 7-4. Manway Assembly

FIGURE & INDEX / SHEET NO.	PART NUMBER	CAGE	DESCRIPTION							UNITS PER ASSY	USABLE ON CODE	SMR CODE
			1	2	3	4	5	6	7			
7-4	08-10251	66144	MANWAY ASSEMBLY .....							1		
1	07-1039S	66144	. WELDMENT, CROSS ARM .....							1		
2	01-8222S	66144	. FLIP LOCK .....							1		
3	02-3042	66144	. BOLT, 3/8-16 BY 3-INCH LG (AP) .....							1		
4	02-3044	66144	. BOLT, 3/8-16 BY 3-1/2-INCH LG (AP) .....							1		
5	02-3089	66144	. NUT, NYLON INSERT, 3/8-16 (AP) .....							2		
6	01-86001	66144	. LID, 16-INCH MANWAY .....							1		
7	06-25025	66144	. GASKET, 16-INCH MANWAY, SV .....							1		
8	01-8710	66144	. RETAINER, GASKET, SV .....							1		
9	02-3091	66144	. NUT, NYLON INSERT, 5/8-18 (AP) .....							2		

- Not Illustrated



**Figure 7-5. Front Undercarriage Assembly**

FIGURE & INDEX / SHEET NO.	PART NUMBER	CAGE	DESCRIPTION	UNITS PER ASSY	USABLE ON CODE	SMR CODE
7-5	08-1018	66144	FRONT UNDERCARRIAGE, 400/600 GALLON.....	1		
1	07-1053	66144	. WELDMENT, FRONT AXLE, 400/600 GALLON.....	1		
2	07-1052	66144	. STEERING ARM, UPPER, 400/600 GALLON.....	1		
3	03-1014	66144	. . BUSHING, Steering Arm.....	1		
4	03-1015	66144	. . BUSHING, Tie Rod.....	1		
5	07-5002	66144	. STEERING ARM, LOWER PLATE.....	2		
6	02-3087	66144	. . NUT, Nylon Insert, 1/2-13 (AP).....	2		
7	02-3022	66144	. . BOLT, 1/2-13 by 1-3/4 Lg. (AP).....	1		
8	02-3081	66144	. . JAM NUT, Nylon Insert, 3/4-16 (AP).....	2		
9	02-3095	66144	. . NUT, Nylon Insert, 3/4-16 (AP).....	2		
10	02-3131	66144	. . WASHER FLAT, 3/4-Inch (AP).....	1		
11	07-1009	66144	. HOUSING, KING PIN.....	2		
12	03-1013	66144	. . BUSHING, King Pin.....	4		
13	07-10105	66144	. . KING Pin.....	2		
14	02-3127	66144	. . . Washer, Flat, 1-1/2-Inch (AP).....	2		
15	02-3093	66144	. . . Nut, Nylon Insert, 1-1/2-12 (AP).....	2		
16	07-10371	66144	. TIE ROD ASSEMBLY, 400/600 GALLON.....	1		
17	03-1016	66144	. . ROD END, Ball Joint.....	1		
18	02-3081	66144	. . JAM NUT, Nylon Insert, 3/4-16.....	2		
19	02-3095	66144	. . . Nut, Nylon Insert, 3/4-16 (AP).....	2		
20	02-3131	66144	. . . Washer, Flat, 3/4-Inch (AP).....	2		
21	07-1020	66144	. TOE LATCH.....	4		
22	04-1054	66144	. SPRING, TOE LATCH.....	1		
23	02-3055	66144	. . BOLT, 5/16-18 by 4-1/2 Lg. (AP).....	1		
24	02-3090	66144	. . NUT, Nylon Insert, 5/16-18 (AP).....	1		
25	07-1103	66144	. TOW BAR.....	1		
26	04-1055	66144	. . HAND GRIP.....	2		
27	02-3063	66144	. . . Hitch Pin (AP).....	1		
28	02-3016	66144	. . . Pin, Cotter (AP).....	1		
29	06-1023	66144	. PAD, MOUNTING.....	2		
30	02-3025	66144	. . BOLT, 1/2-13 by 4-1/2 Lg (AP).....	4		
31	02-3087	66144	. . NUT, Nylon Insert, 1/2-13 (AP).....	4		
32	08-1011	66144	. FRONT HUB ASSEMBLY (See Fig. 7-12).....	2		
- 33	07-10201	66144	. WHEEL ASSEMBLY (See Figure 7-11).....	2		

- Not Illustrated

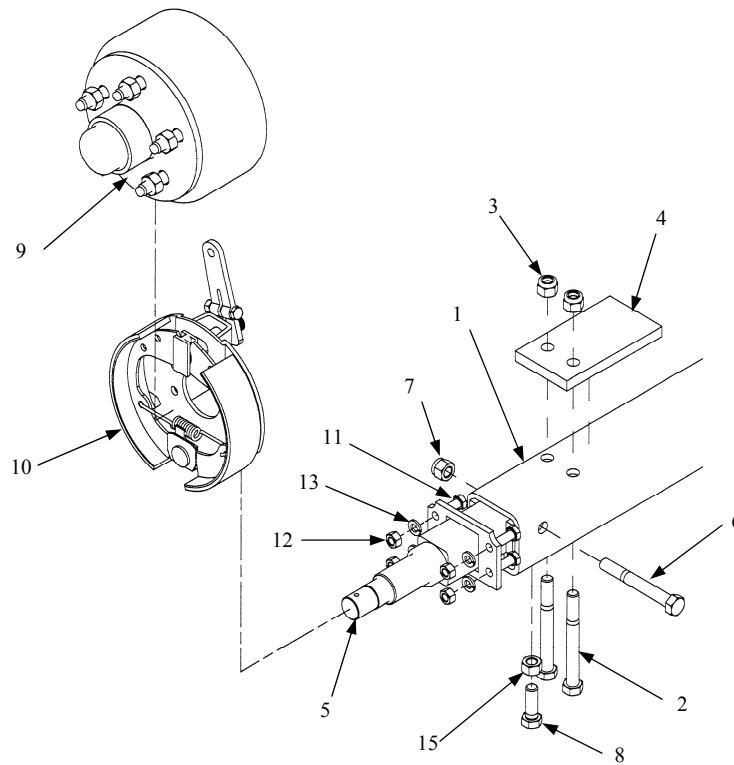

Figure 7-6. Rear Undercarriage Assembly

FIGURE & INDEX / SHEET NO.	PART NUMBER	CAGE	DESCRIPTION							UNITS PER ASSY	USABLE ON CODE	SMR CODE
			1	2	3	4	5	6	7			
7-6	08-10301	66144	ASSEMBLY, REAR UNDERCARRIAGE, 400/600 GALLON .....							1		
1	05-1023	66144	. REAR AXLE TUBE, 400/600 GALLON .....							1		
2	02-3025	66144	. BOLT, 1/2-13 by 4 1/2-INCH (AP) .....							4		
3	02-3087	66144	. NUT, NYLON INSERT, 1/2-13 (AP) .....							4		
4	06-1012	66144	. MOUNT PAD, REAR .....							2		
5	07-1010	66144	. WELDMENT, Rear Spindle .....							2		
6	02-3024	66144	. BOLT, 1/2-13 by 4-Inch Lg (AP) .....							2		
7	02-3087	66144	. NUT, Nylon Insert, 1/2-13 (AP) .....							2		
8	02-3026	66144	. BOLT, 1/2-13 by 1-1/2-Inch Lg (AP) .....							2		
9	08-10111	66144	. REAR HUB AND DRUM ASSY (SEE FIG. 7-13) .....							2		
10	825155	66144	. BRAKE ASSEMBLY .....							2		
11	02-3050	66144	. BOLT, 3/8-16 by 1-Inch Long (AP) .....							8		
12	02-3072	66144	. NUT, 3/8-16 (AP) .....							8		
13	02-3143	66144	. LOCK WASHER, 3/8 (AP) .....							8		
- 14	07-10201	66144	. WHEEL ASSEMBLY (SEE FIG. 7-11) .....							2		
15	02-3068	66144	. NUT, 1/2-13, PLATED .....							2		

- Not Illustrated

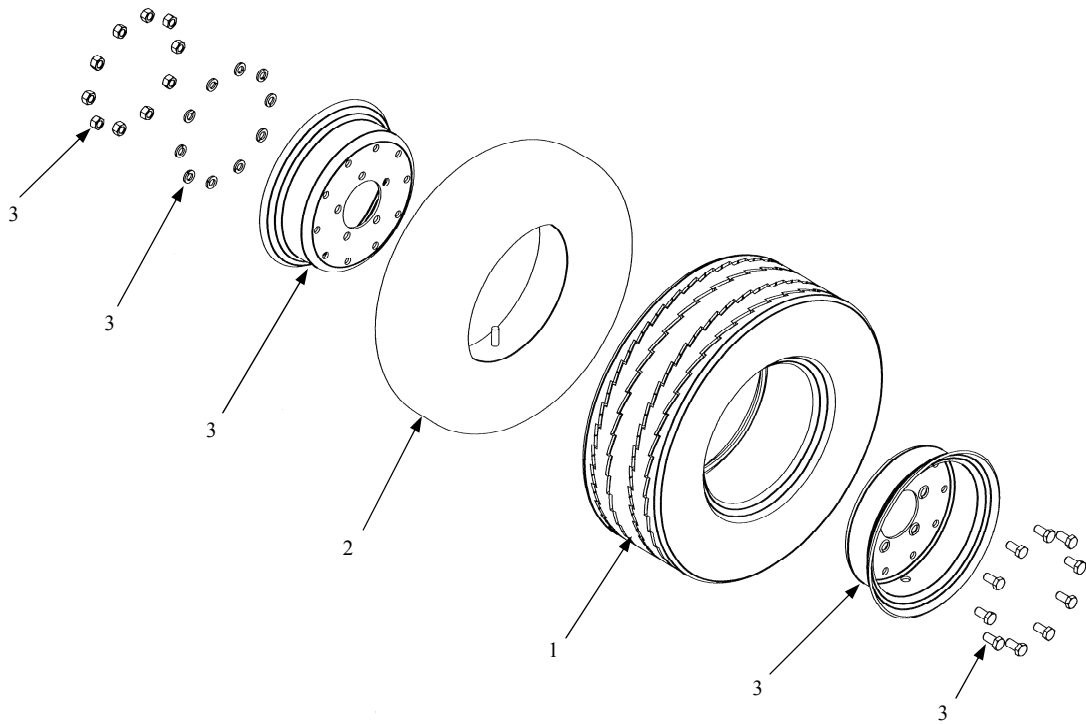
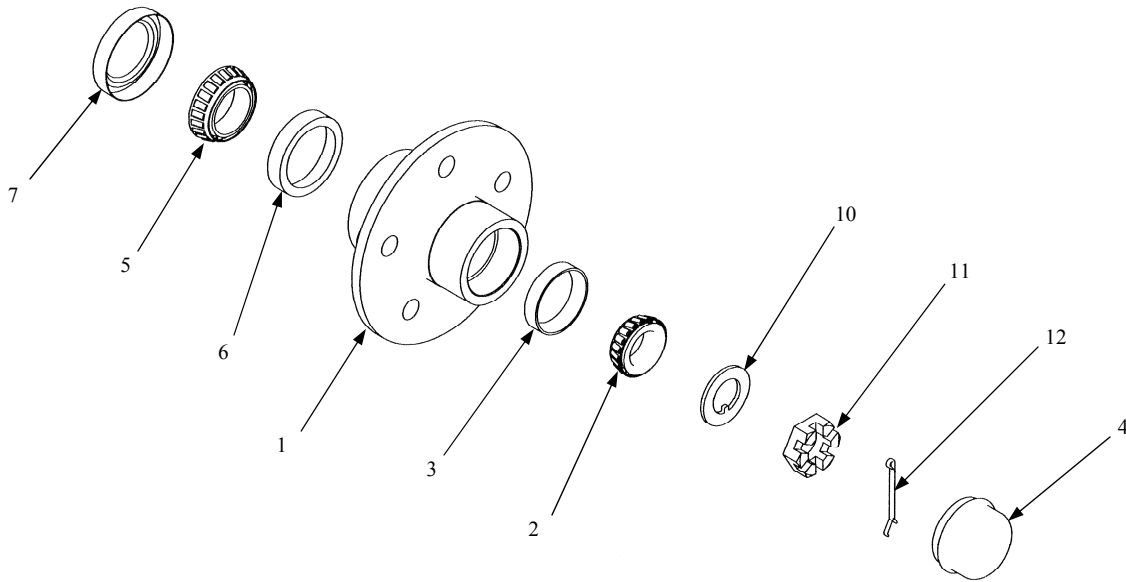

Figure 7-7. Wheel Assembly

FIGURE & INDEX / SHEET NO.	PART NUMBER	CAGE	DESCRIPTION							UNITS PER ASSY	USABLE ON CODE	SMR CODE
			1	2	3	4	5	6	7			
7-7	07-10201	66144	WHEEL ASSEMBLY .....							4		
1	04-10221	66144	. TIRE, 20.5 x 8.0-10, E-RANGE .....							1		
2	04-1045	66144	. TUBE, INNER .....							1		
3	04-1020	66144	. SPLIT RIM WHEEL ASSEMBLY .....							1		

- Not Illustrated



**Figure 7-8 Front Hub Assembly**

FIGURE & INDEX / SHEET NO.	PART NUMBER	CAGE	DESCRIPTION							UNITS PER ASSY	USABLE ON CODE	SMR CODE
			1	2	3	4	5	6	7			
7-8	08-1011	66144	FRONT HUB ASSEMBLY .....							2		
1	04-1017	66144	. HUB, FRONT AXLE.....							1		
2	04-1014	66144	.. BEARING, Outer.....							1		
3	04-1016	66144	.. RACE, Outer Bearing .....							1		
4	04-1019	66144	.. CAP, Dust .....							1		
5	04-1013	66144	.. BEARING, Inner .....							1		
6	04-1015	66144	.. RACE, Inner Bearing .....							1		
7	04-1012	66144	.. SEAL, Bearing .....							1		
-8	02-1017	66144	.. STUD, Wheel.....							5		
-9	02-3065	66144	... NUT, Lug (AP) .....							5		
10	02-12055	66144	... WASHER, Spindle (AP) .....							1		
11	02-1205	66144	... NUT, Castle (AP) .....							1		
12	02-3018	66144	... PIN, Cotter (AP).....							1		

- Not Illustrated

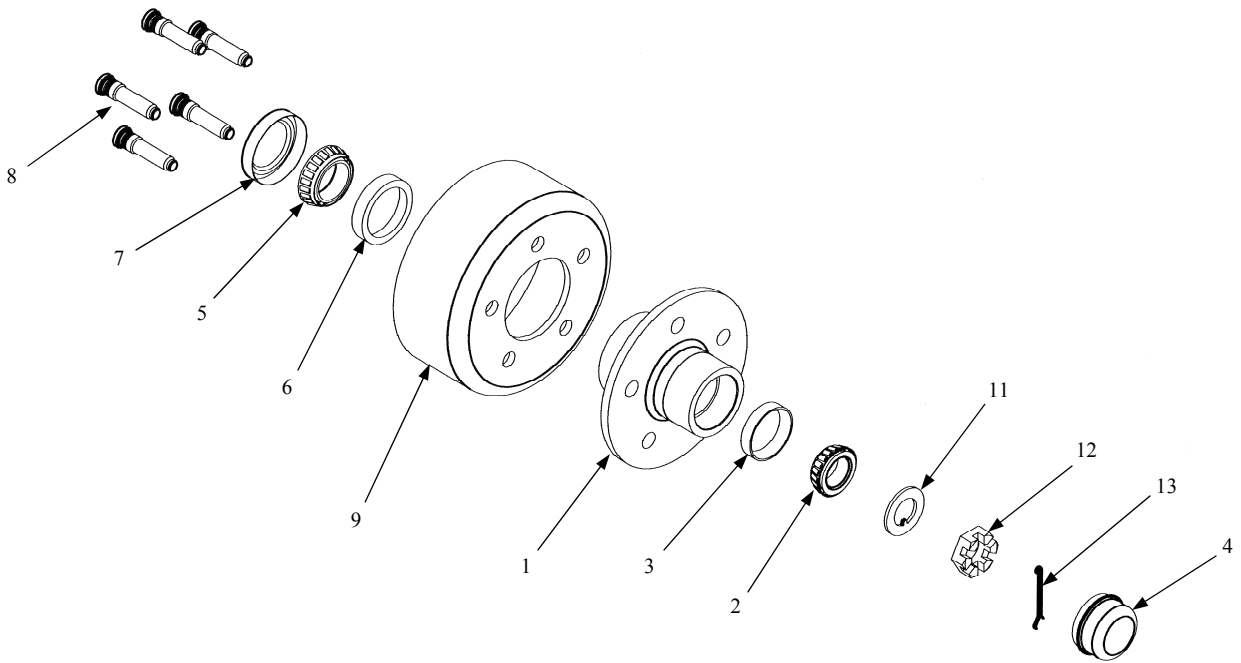

**Figure 7-9. Rear Hub Assembly**

FIGURE & INDEX / SHEET NO.	PART NUMBER	CAGE	DESCRIPTION							UNITS PER ASSY	USABLE ON CODE	SMR CODE
			1	2	3	4	5	6	7			
7-9	08-10111	66144	REAR HUB ASSEMBLY.....							2		
1	05-1020	66144	. HUB, REAR AXLE .....							1		
2	04-1014	66144	. . BEARING, Outer .....							1		
3	04-1016	66144	. . RACE, Outer Bearing .....							1		
4	04-1019	66144	. . CAP, Dust .....							1		
5	04-1013	66144	. . BEARING, Inner .....							1		
6	04-1015	66144	. . RACE, Inner Bearing .....							1		
7	04-1012	66144	. . SEAL, Bearing .....							1		
8	02-1017	66144	. . STUD, Wheel.....							5		
9	05-1021	66144	. . DRUM, Brake .....							1		
- 10	02-3065	66144	. . . NUT, Lug (AP) .....							5		
11	02-12055	66144	. . . WASHER, Spindle (AP) .....							1		
12	02-1205	66144	. . . NUT, Castle (AP).....							1		
13	02-3018	66144	. . . PIN, Cotter (AP).....							1		

- Not Illustrated

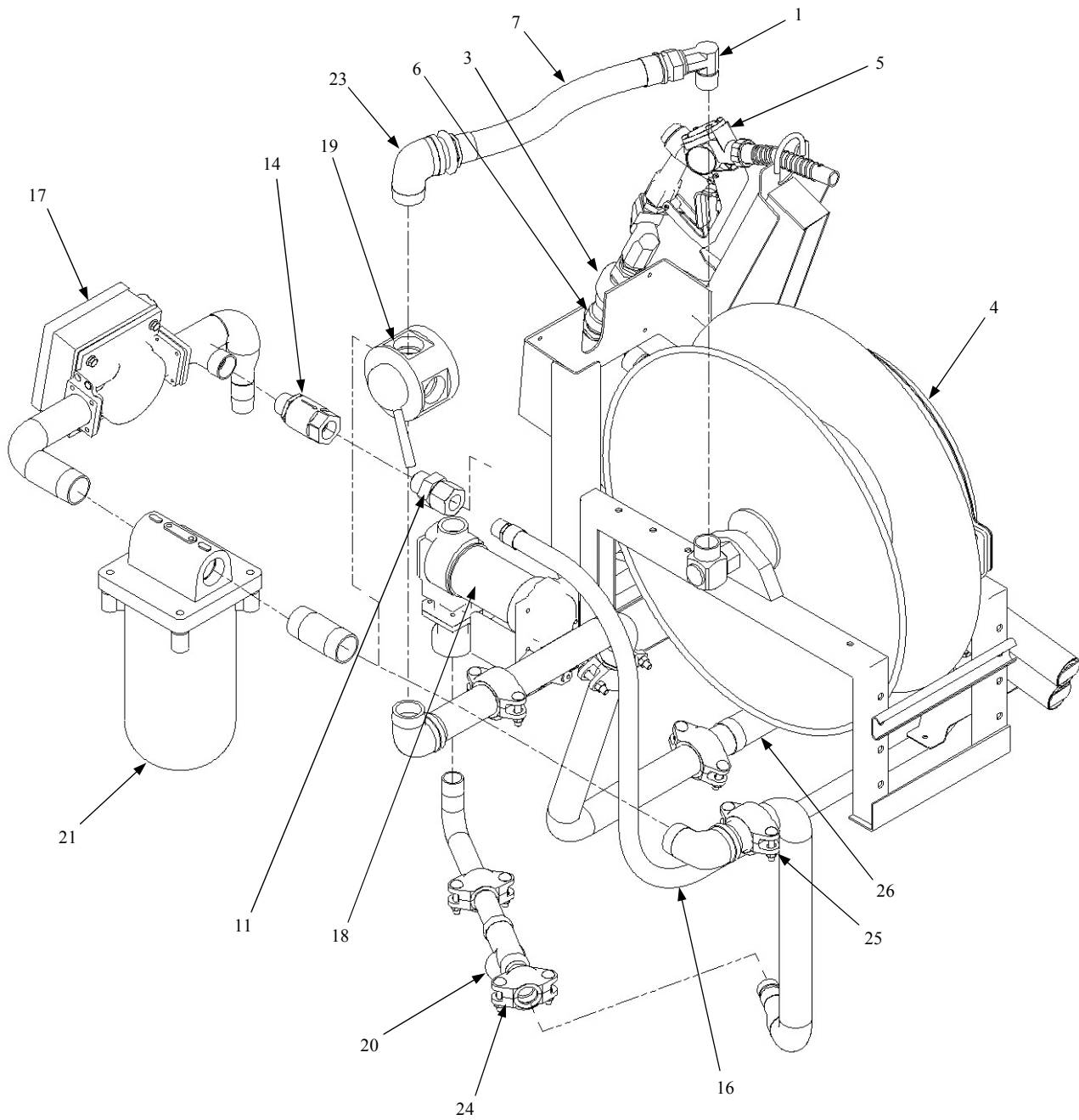
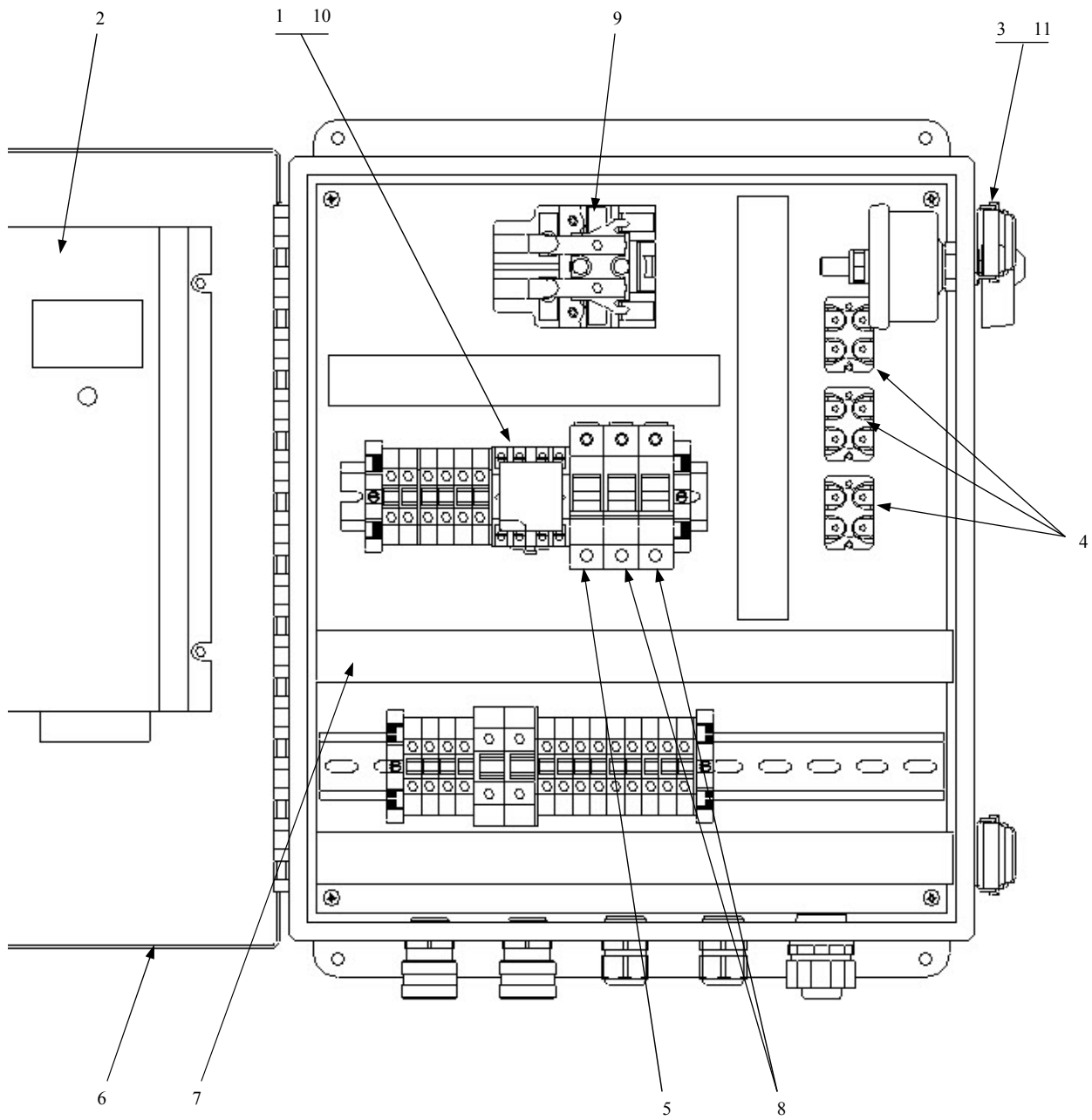

Figure 7-10. Plumbing System

FIGURE & INDEX / SHEET NO.	PART NUMBER	CAGE	DESCRIPTION							UNITS PER ASSY	USABLE ON CODE	SMR CODE
			1	2	3	4	5	6	7			
7-10	25-5003	66144	PLUMBING SYSTEM .....							1		
1	03-10652	66144	. STREET ELBOW, 1-NPT SWIVEL .....							1		
-2	03-4032	66144	. NIPPLE, HEX, 1" .....							1		
3	04-0201	66144	. FUEL SWIVEL, 1" BY 1" .....							1		
4	04-2220	66144	. HOSE REEL .....							1		
5	04-8031- M001	66144	. NOZZLE, 1" DIESEL .....							1		
6	25-5006	66144	. FUEL HOSE, 1" BY 35' .....							1		
7	25-5007	66144	. HOSE ASSY, FUEL SUPPLY .....							1		
-8	25-5008	66144	. SOFT DEFUEL WAND .....							1		
-9	25-5009	66144	. RIGID DEFUEL WAND .....							1		
-10	03-111393	66144	. QUICK DISCONNECT, MALE .....							1		
11	03-4035	66144	. SWIVEL ADAPTOR, 1" BY 3/4" .....							1		
-12	03-4036	66144	. SWIVEL ELBOW, 1" X 3/4" .....							1		
-13	04-0203	66144	. BALL STOP .....							1		
14	04-8097	66144	. VALVE, CHECK, 1" X 10 PSI .....							1		
-15	04-8100	66144	. SPIRAL WRAP .....							1		
16	25-5015	66144	. HOSE ASSY, PRV TO TANK .....							1		
17	04-0142	66144	. METER, 1-1/2" .....							1		
18	04-0174	66144	. FUEL PUMP, 12VDC .....							1		
19	04-10310	66144	. VALVE, SELECTION .....							1		
20	04-4200	66144	. Y-STRAINER, 1" .....							1		
21	04-8094	66144	. FILTER HOUSING .....							1		
-22	04-8094-01	66144	. FILTER ELEMENT .....							1		
23	03-00681	66144	. STREET ELBOW, 1-1/2" .....							1		
24	03-21101	66144	. VICTAULIC COUPLING, 1" .....							2		
25	03-21151	66144	. VICTAULIC COUPLING, 1-1/2" .....							2		
26	25-5002	66144	. HOSE ASSY, TANK TO VALVE .....							1		

- Not Illustrated



**Figure 7-11. Main Electrical Panel**

FIGURE & INDEX / SHEET NO.	PART NUMBER	CAGE	DESCRIPTION							UNITS PER ASSY	USABLE ON CODE	SMR CODE
			1	2	3	4	5	6	7			
7-11	15-00127	66144	MAIN ELECTRICAL ENCLOSURE .....							1		
1	04-80161	66144	. BASE, RELAY, CONTROL, 8-PIN .....							1		
2	04-8060	66144	. 12VDC X 30AMP BATTERY CHARGER .....							1		
3	15-00018	66144	. BATTERY DISCONNECT SWITCH .....							1		
4	15-00040	66144	. DIODE, DUEL 100 VOLT, 60 AMP .....							3		
5	15-00093	66144	. CIRCUIT BREAKER, 30-AMP .....							1		
6	15-00103- M001	66144	. ELECTRICAL ENCLOSURE .....							1		
7	15-00104- M001	66144	. ELECTRICAL BACK PANEL .....							1		
8	15-00106	66144	. CIRCUIT BREAKER, 3-AMP .....							2		
9	15-00107	66144	. RELAY, 12VDC, DPDT .....							1		
10	15-00042	66144	. RELAY, CONTROL, 12VDC .....							1		
11	105-0004- D002	66144	. DECAL, BATTERY DISCONNECT .....							1		

- Not Illustrated

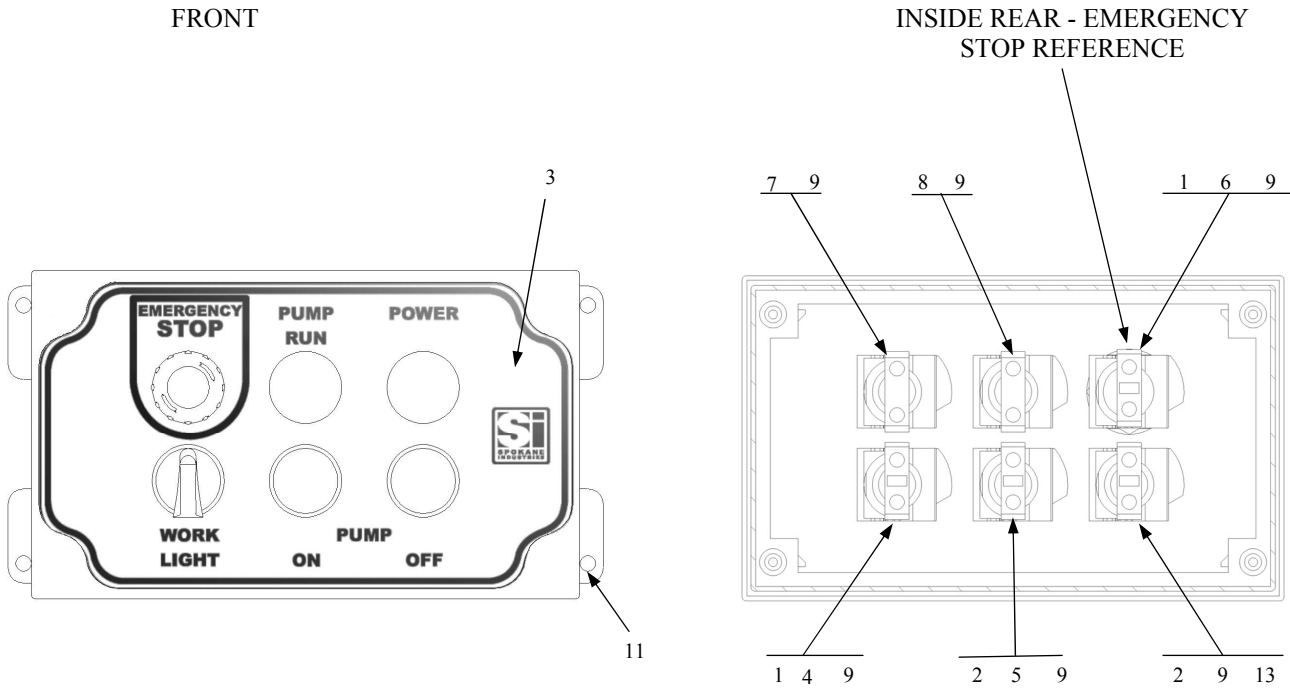

Figure 7-12. Operator Console

FIGURE & INDEX / SHEET NO.	PART NUMBER	CAGE	DESCRIPTION							UNITS PER ASSY	USABLE ON CODE	SMR CODE
			1	2	3	4	5	6	7			
7-12	15-00110	66144	OPERATOR CONSOLE.....							1		
1	04-8022	66144	. CONTACT BLOCK, N/C, 22MM.....							2		
2	04-8023	66144	. CONTACT BLOCK, N/O, 22MM.....							2		
3	06-7047	66144	. DECAL, OPERATOR CONSOLE.....							1		
4	15-00002	66144	. PUSHBUTTON, RED, 22.5MM.....							1		
5	15-00003	66144	. PUSHBUTTON, GREEN, 22.5MM.....							1		
6	15-00004	66144	. OPERATOR, 30MM MUSHROOM ESTOP.....							1		
7	15-00008	66144	. PILOT LIGHT, YELLOW.....							1		
8	15-00009	66144	. PILOT LIGHT, GREEN.....							1		
9	15-00010	66144	. LATCH, METAL SWITCH.....							6		
-10	15-00017	66144	. CORD CONNECTOR.....							1		
11	15-00047	66144	. ENCLOSURE, 6-HOLE.....							1		
-12	15-00126	66144	. BULB, LED, 12V DC.....							2		
13	15-00089	66144	. SWITCH, 2-POS SELECTOR.....							1		

- Not Illustrated

]   
  
This page left intentional blank.