



CONFIDENTIAL PROPRIETARY INFORMATION

Reproductions of this data or the manufacturing of products from this data by anyone other than Spokane Stainless Technologies™, Inc. of Spokane Valley Washington is strictly prohibited without written consent. The Spokane Stainless Technologies logo, is a registered trademark of Spokane Stainless Technologies, Inc..

TECHNICAL MANUAL

UAS 600 Gallon Defuel / Fuel Cart

Spokane Stainless Technologies™, Inc.
SPOKANE STAINLESS TECHNOLOGIES, INC.

This document discloses subject matter in which Spokane Stainless Technologies, Inc. has Proprietary rights and such subject matter shall not, without the written permission of Spokane Stainless Technologies, Inc. be either (A) used, released or disclosed in whole or in part outside the government, (B) used in whole or in part by the government, for manufacture, or (C) used by a party other than the government, except for (1) emergency repair or overhaul work only, by or for the government, where the item or process concerned is not otherwise reasonably available to enable time and performance of the work, provided that release of disclosure hereof outside the government shall be made subject to a prohibition against further use, release of disclosure, or (2) release to a foreign government, or for emergency repair or overhaul work by or for such government under the conditions of (1) above. This legend shall be marked on any reproduction hereof in whole or in part.

©COPYRIGHT 2022 By SPOKANE STAINLESS TECHNOLOGIES INC.

MNUL-008

Revision E

SEPTEMBER 2022

1.0	Introduction.....	Page 4
1.1	Component Identification.....	Page 5
1.2	Specifications.....	Page 6
1.3	Daily Inspection Checklist.....	Page 7
1.4	Preventative Maintenance Chart.....	Page 7
2.0	Safety Guidelines.....	Page 8
2.1	General Safety Instructions.....	Page 8
2.2	Protective Clothing.....	Page 8
2.3	Static Bonding and Grounding and Other Fire Hazard Precautions.....	Page 8
2.4	Lockout / Tagout.....	Page 8
2.5	Area of Use.....	Page 8
3.0	Operation Instructions.....	Page 9
3.1	Shipment Preparation	Page 9
3.2	Controls and Indicators.....	Page 9
3.3	Defueling the Aircraft.....	Page 10
3.4	Fueling the Aircraft.....	Page 11
3.5	Taking Samples Using the Sample Ports.....	Page 12
3.6	Fuel Moisture Removal Low Point Drain/ Fuel.....	Page 12
	Filter Housings	

4.0	Maintenance, Assembly and Repair	Page 13
4.1	Repair and Replace Instructions.....	Page 13
4.2	General Tank Instructions.....	Page 13
4.3	Manway Assembly and Maintenance.....	Page 14
4.4	Front Undercarriage Assembly.....	Page 15
4.5	Front Wheel Assembly Removal.....	Page 15
4.6	Front Hub Assembly.....	Page 15
4.7	Tow Latch Assembly.....	Page 16
4.8	Spindle Assembly.....	Page 17
4.9	Steering Arm Assembly.....	Page 17
4.10	Tie Rod Assembly.....	Page 17
4.11	Front Undercarriage Assembly Removal.....	Page 18
4.12	Rear Undercarriage Assembly.....	Page 18
4.13	Rear Wheel Assembly Removal.....	Page 18
4.14	Rear Hub/Brake Drum Assembly.....	Page 19
4.15	Mechanical Brake Assembly.....	Page 19
4.16	Parking Brake Assembly and Adjustment.....	Page 20
4.17	Brake Handle and Cable Assembly.....	Page 20
4.18	Rear Undercarriage Assembly Removal.....	Page 21
4.19	Wheel Assembly.....	Page 21
4.20	Removing the Fuel Pump.....	Page 22
4.21	Removing the Fuel Meter.....	Page 22
4.22	Removing the Filter Housing.....	Page 22
4.23	Removing the Hose Reel.....	Page 22
4.24	Removing the Defuel Pump.....	Page 22
4.25	Removing the Defuel Meter.....	Page 22
4.26	Changing Fuel Filter Element.....	Page 23
4.27	Fuel Pump Strainer Removal and Cleaning.....	Page 24
4.28	Troubleshooting the UAS Cart.....	Page 25
5.0	Parts Breakdown	Page 26

Drawing No.

1.0	Overview, Component Identification.....	Page 27
2.0	Pump Components.....	Page 28
3.0	Manway Assembly.....	Page 29
4.0	Front Undercarriage.....	Page 30
5.0	Rear Undercarriage and Axle.....	Page 31
6.0	Front Hub Assembly.....	Page 32
7.0	Rear Hub & Drum Assembly.....	Page 33
8.0	Wheel & Tire Assembly.....	Page 34

SECTION 1.0

INTRODUCTION



IMPORTANT

YOU MUST READ THIS MANUAL IN ITS ENTIRETY BEFORE OPERATING, SHIPPING OR PERFORMING MAINTENANCE PROCEDURES. FLAMMABLE AND COMBUSTIBLE VAPORS CAN CAUSE FIRE, AND/OR EXPLOSION AND CAN LEAD TO SERIOUS INJURY OR DEATH.

The instructions in this manual cover the operation and maintenance of the UAS Cart manufactured by Spokane Stainless Technologies, Inc. of Spokane Valley, Washington.

DESCRIPTION

Throughout this manual the unit will be referred to as the UAS Cart. The UAS Cart is a 600-gallon fuel / defuel cart designed to provide a portable, self-contained defueling/ fueling system for refueling UAS. The UAS Cart is easy to use and maintain.

The UAS Cart consists of an inner tank assembly and an outer tank, otherwise known as tight wrap construction. It also consists of two pumps, two fuel meters, a fuel filter and a plumbing system that allows for fuel to recirculate through the system, as well as go in and out of the tank for either defueling or fueling purposes of UAS.

When fuel is extracted, it is filtered through the plumbing system and placed back into the tank with a 50-foot fuel hose. There is a rigid and a soft extraction wand so that the user can fuel and defuel different size tanks.

Additional features of the UAS Cart include a spill containment kit, and cabinet lighting, which makes it easier and safer to fuel up at night.

Refer to the specifications chart (Section 1.2) for more information regarding dimensions, fuel capacity and other information on the 600-gallon UAS Cart. Refer to Section 1.4 for the Daily Inspection Checklist and Section 1.5 for The Preventive Maintenance Chart.

Section 1.1

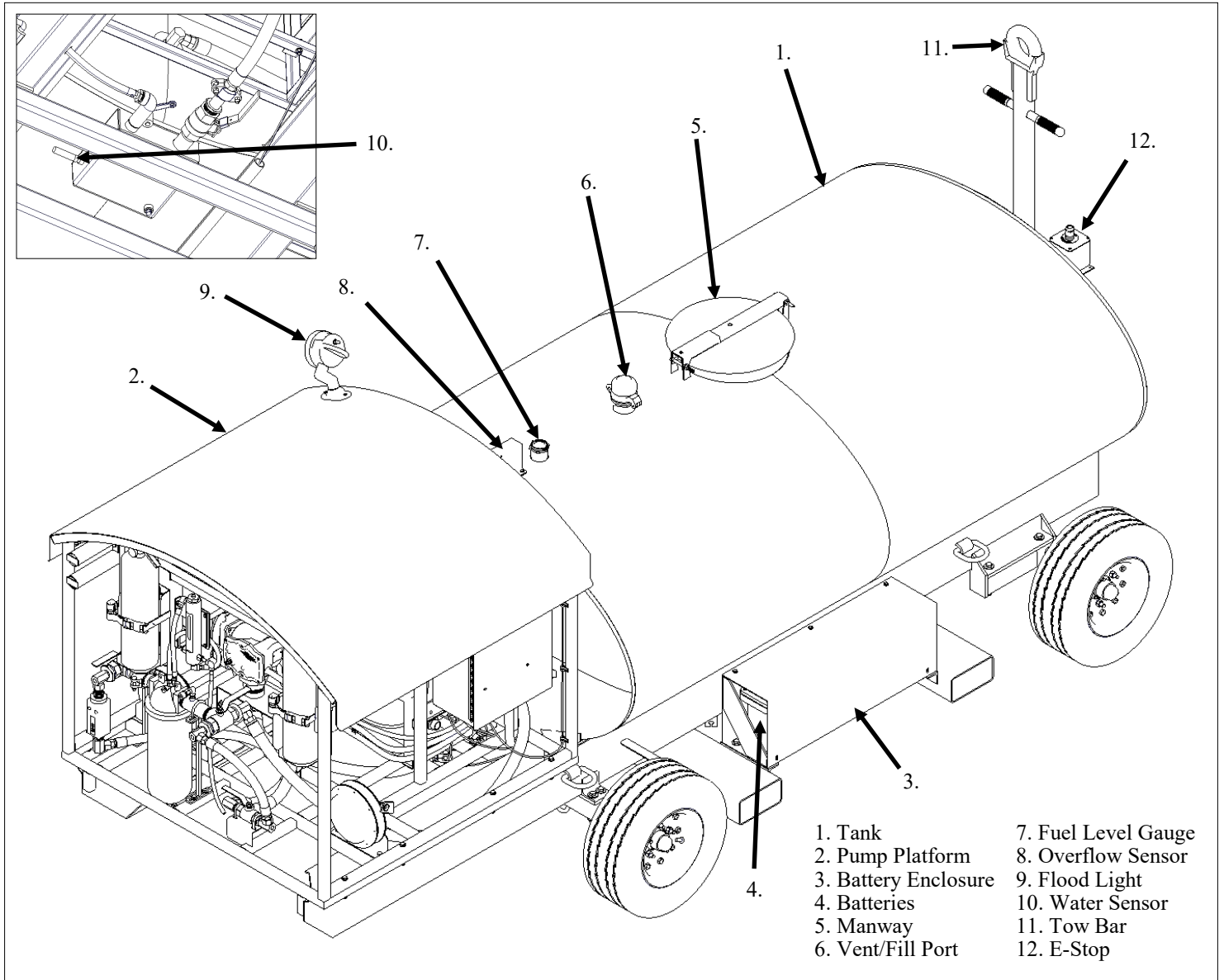

Figure 1-1 Component Identification

1.2

Specifications for the UAS Cart 600 Gallon

Tank Volume:	
Nominal Capacity	600-gallons
Max Capacity	660-gallons
Equipment Dimensions:	
Length (Tow bar down)	224-inches
(Tow bar up)	163-inches
Width (Tire to tire)	76-inches
Height (Tow bar down)	70-inches
(Tow bar up)	75-inches
Weight (Empty)	2,700-pounds
(Full, at nominal capacity with fuel)	6,980-pounds
Ground Clearance (At tow bar)6-inches
(At axle)8-inches
Environmental Conditions:	
Operating Temperature Range	-25°F to 110°F
Storage Temperature Range	-40°F to 150°F
Flow and Pressure:	
Fueling Flow Rate (nominal)	11-GPM
Fueling Pressure	<10-PSI
Fuel Extraction Flow Rate (nominal)	1-3-GPM
Electrical Characteristics:	
Voltage	24VDC
On-board Batteries	Dual 12Volt Optima Blue tops wired in series (24 volt output)
On-board Charging	120 volt AC input / 28 Volt DC dual output
Cabinet Lighting	LED
Circuit Protection	Yes, circuit breakers
Duty Cycle:	
Pump (Fueling and Extraction)	30-minutes ON, 30-minutes OFF
Towing Characteristics:	
Speed, Forward Direction	15-MPH
Speed, Backward Direction	(hand push/pull only)
Turning Radius (Curb to curb)	372-inches
Wheels and Tires:	
Tire Size	20.5 x 8.0-10
E Range Tire Pressure (Cold) (See Sidewall)	90-PSIG
Lug Nuts Torque	100 ft.-lbs.
Split Rim Nuts Torque	75 ft.-lbs.
Other Characteristics:	
Double Wall Construction	Yes
Tie-down Points	Yes, 4 D-rings & 4 Tie-Downs
Fork-lift Ready	Yes, 4 x 8 pockets
Undercarriage Rating	4,000lb

1.3

Daily Inspection Checklist

Part to be inspected	What to Look For				Check Off Once Inspected
Wheels	Are tires damaged?	Are there loose or missing lug nuts?			
Brakes	Inspect for proper function	Are brakes properly adjusted?			
Towbar	Are there cracks in welds?	Are there missing attachment pins?	Are there missing retaining clips?		
Tank	Are there leaks or any obvious damage?	Does Manway close properly?	Are there loose or missing components in the undercarriage mounting hardware?		
Fueling Nozzle	Are there any leaks?				
Ground Reel	Is cable end securely fastened to cable?				
Valves	Are valves functioning properly?				
Fuel Filter Housings	Are there any cracks?	Are there any leaks?			
Fuel Hose	Are there any cracks?	Are there any leaks?	Are there any rub spots?	Are fitting ends operational?	
Low-Point Drain	Is water drained from tank low-point sump?				

1.4

Preventative Maintenance Chart

Item	Interval	Action
Manway Seal	Monthly	Inspect for tears, cracks and compression damage. Refer to Section 4.3 for maintenance instructions.
Brakes	Quarterly	Check for proper adjustment and make any adjustments using sections 4.15, 4.16 and 4.17.
12 Volt batteries	6 Months	Check battery cell fluid level. If the batteries need to be serviced, remove the battery box before servicing the batteries.
Tank Weldment	Yearly	Inspect both inner and outer tank welds for cracks. Remove plug from outer tank test fitting and inspect for fuel evidence.
Wheel Bearings	Yearly	Inspect for damage and replace components when needed. Pack wheel bearings with grease. Use sections 4.8 and 4.17 For maintenance.

SECTION 2.0

SAFETY GUIDELINES

Within this manual are guidelines and safety recommendations for use of the UAS Cart. It is the responsibility of the end user to completely read this manual and comply with all local, state and federal laws and **regulations applicable for defueling and fueling aircraft**. Spokane Industries Inc. is not responsible for industry specific information on safety management, employment safety, health standards, safety codes, etc. Contact your local safety manager or industrial safety representative. It is the responsibility of the end user to ensure persons operating this equipment:

- **Are trained, authorized and permitted to use the equipment.**
- **Have physical and the mental ability to operate this equipment safely.**
- **Are aware of the potential hazards associated with this equipment, i.e. static electricity, electrical shock, fuel spills and pinch points.**

2.1 General Safety Instructions

This manual describes physical and chemical processes which may cause injury or death to personnel, or damage to equipment if not properly followed. This safety summary includes general safety precautions that must be understood and applied during operation and maintenance to ensure safety and protection of equipment.

2.2 Protective Clothing

When fuels are being handled, approved equipment such as gloves, eye protection, face shields, etc. shall be used.

2.3 Static Bonding and Grounding and Other Fire Hazard Precautions

Improper static bonding and grounding can lead to a fire, and as with any other equipment dealing with fuel, there is always a risk of fire if all safety precautions are not followed or the equipment is not used correctly. Make sure to read and understand all instructions before operating this equipment.

2.4 Lockout / Tagout

Personnel shall be aware of the hazards associated with unguarded machinery parts, capacitors, gaseous and wet pipe systems, spring loaded devices, etc. Lockout / Tagout the energy source prior to performing maintenance, adjustment or other procedures that would bypass safety guards, barriers, or otherwise expose personnel to hazardous energy sources. Any equipment, machine or process that could unexpectedly energize, start-up or release energy will be equipped with a means to lockout / tagout the energy sources.

2.5 Area of Use

This equipment has been designed to operate outdoors only. Flammable and/or combustible vapors in ignitable quantities could be produced under certain circumstances. Additionally, local protocols must be consulted to determine if fuel draining equipment can be used in the location being considered.

SECTION 3.0

OPERATION INSTRUCTIONS

3.1 Shipment Preparation

⚠ WARNING

Flammable and combustible vapors must be removed from tank before shipping to prevent a fire and/or explosion. If this step is not taken, serious injury or death could occur

- Drain the tank of all liquid products by running the unit dry and then by opening the drain plug.
- Evacuate all flammable and/or combustible vapors from the tank using an approved ventilation method.
- Ensure the Manway Assembly and Fill/Vent port is secured.

Loading the UAS Cart for Truck Shipment

⚠ CAUTION

Inserting fork extensions into fork pockets should be the only means of lifting the UAS Cart for shipment. Damage to the equipment will occur if the equipment is lifted from any other location.

- Ensure the steps in section 3.1 have been completed.
- Set the parking brake.
- Approach the unit from either side.
- Place on truck.
- Secure to truck bed using attachment points on tank weldment.

Loading the UAS Cart for Air Shipment

⚠ CAUTION

Do not back equipment by any means other than hand pushing/pulling, or it will cause damage to the equipment.

- Ensure the steps in section 3.1 have been completed.
- Follow specific aircraft loading requirements.
- Load equipment by towing forward only by self propelled tow methods or by hand pushing/pulling.
- After placement in aircraft, lock tow bar in upright position.
- Ensure Parking Brake is set.
- Ensure the Manway Assembly and Fill/Vent port is secured.

3.2 Controls and Indicators

Description	Functions
Battery Switch	Main power disconnect
E-Stop Switch	Emergency shut down switch
Fuel Filter petcock	Maintains the fuel filter
Fuel Meter	Gauge that shows the amount of fuel passing through the system during defueling and fueling operations
Operator Console	Turns Defuel / Fuel pumps both ON and OFF
Parking Brake Handle	Sets Parking Brake
Liquid Level Gauge	Located on the top centerline of the tank, this shows how much fuel is in the tank.
Sample Port Valves	There are two of these. One is located before the filter and the other is located after the filter. These are used to take fuel samples from the tank.
LED Work Lights	Located on top of the UAS Cart and underneath the top hood, these are used to light the working area.

3.3 Defueling the Aircraft

⚠ WARNING

Never operate the UAS Cart in a closed area or in an area with little or no ventilation.

All fuels are flammable, do not allow sources of ignition within 50 feet of the UAS Cart.

Make sure there is enough room in the tank to store the fuel being removed from the aircraft.

- a. Set brakes by moving the handle so it points upward.
 - b. Chock tires if chocks are available.
 - c. Attach static bonding/grounding cables by locating reel, and pulling cable outward until desired length has been taken out.
 - d. Allow cable to retract until it stops. Attach to an approved bonding/grounding site.
 - e. Uncoil 50-foot Hose assembly from hose reel.
 - f. Remove fueling nozzle at quick disconnect, attach the defuel adapter. Insert into aircraft.
 - g. Reference figure 3-1, and position the three ball valves accordingly.
 - h. Turn on the Battery Switch. The "POWER ON" indicator lamp will light up on the operator console.
 - i. Make sure E-stop switches are in the non-stopped condition by twisting them the direction of the arrow and allowing them to spring outward.
 - j. Turn switch to defuel mode.
 - k. Start the fuel pump by pushing the "Pump ON" button.
 - l. Monitor fuel meter to remove desired quantity of fuel. (Hold display button to reset total 2.)
 - m. If too much fuel is received into the tank, the Fuel Limit switch will activate and cut power to the system. Defueling operation must cease. Pump will turn off and pump run light will not illuminate.
 - n. Disconnect the suction side of the pump.
 - o. Adjust the valving and turn switch to go into fueling mode.
 - p. Find an appropriate receptacle, and connect the UAS Cart into the receptacle.
 - q. On the side of the electrical box, turn the liquid level override switch clockwise. This will allow you to bypass the level sensor. The red light will illuminate when the pump is activated and override is engaged.
 - r. On the operator console, press the pump run button.
 - s. The pump will activate again and fueling/defueling can continue.
 - t. Remove desired amount of fuel from tank.
 - u. Switch off liquid level override switch, continue defueling aircraft.
 - v. Turn off fuel pump by depressing the "PUMP OFF".
 - w. Retract the fuel hose from aircraft
 - x. Turn off main battery switch.
 - y. Recoil hose and store.
- Normal safety procedures must be followed during this process.
 - Filling of the tank should be done through the fuel fill service port.
 - Filling personnel must check fuel gauge when conducting this operation.
 - Filling personnel must also have the man-way open for visual inspecting during this operation.

NOTE: Repeat steps H through L if defueling any other fuel cells on the aircraft

3.4 Fueling the Aircraft

⚠ WARNING

Never operate the UAS Cart in an enclosed area. Proper ventilation must be maintained at all times. All fuels are flammable, do not allow sources of ignition within 50 feet of the UAS Cart.

Do not attempt to charge batteries while using the 24 Volt electric fuel pumps, damage to charger will occur.

- a. Set brakes by moving Brake lever upright.
- b. Chock tires if chocks are available.
- c. Attach static bonding/grounding cables by locating reel, and pulling cable outward until desired length has been taken out.
- d. Allow cable to retract until it stops. Attach to an approved bonding/grounding site.
- e. Reference figure 3-1, and position the three ball valves accordingly.
- f. Uncoil and fully extend hose.
- g. If not already connected, remove nozzle from stowed position and attach to hose end.
- h. On electrical box turn main power switch ON by turning clockwise.
- i. Make sure E-stop switches are in the non-stopped condition by twisting them the direction of the arrow and allowing them to spring outward.
- j. Turn switch to fuel mode. Start the fuel pump by depressing the "PUMP ON" button.
- k. Ensure battery charge indicator indicates enough charge for operation.
- l. Open aircraft fuel tank and insert nozzle.
- m. Fill tank to desired capacity.
- n. Remove nozzle, close fuel tank and turn off pump.

- o. Turn main power switch OFF at electrical box.
- p. Retract fuel hose by pulling on retracted hose and allow the hose reel to start retrieving hose, control the rate of retraction by providing a small amount of resistance against the hose reel.
- q. Stow fuel nozzle in nozzle holder.

⚠ CAUTION

Improper grounding may result in an ignition source.

NOTE: Periodically monitor differential pressure gauge during fueling operations. This allows real time reading of filter contamination level. Red scale begins at 15 PSI differential pressure, which means filter needs to be replaced.

Figure 3-1 Fuel / Defuel Diagram

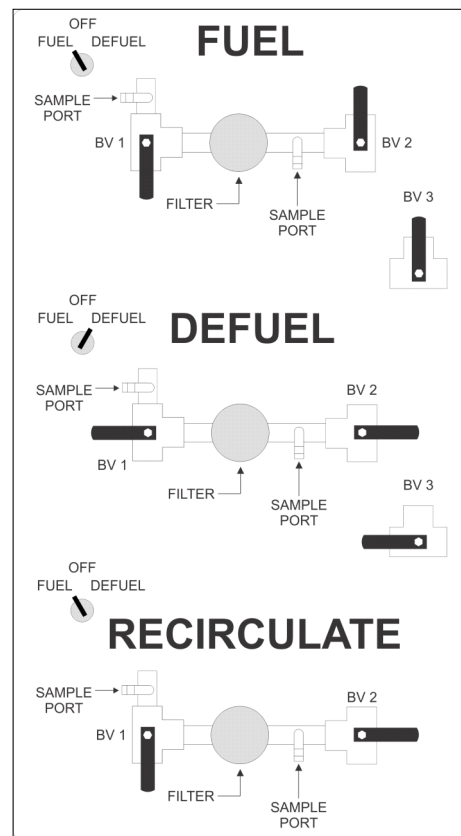

3.5 Taking Samples Using the Sample Ports

There are two ports used solely for taking for taking fuel samples. The sample ports are located before and after the filter. (See Figure 3-2)

- a. Make sure parking brake is set.
- b. Attach bonding/grounding cables.
- c. To take fuel before filtering, unscrew the cap to the sample Port (1) shown in Figure 3-2.
- d. After filtering fuel samples can be taken by unscrewing cap to the fuel sample port (2).

3.6 Fuel Moisture Removal Low Point Drain/ Fuel Filter Housings

The low point drain is located at the rear of the tank assembly. (See Figure 3-3)

- a. Make sure that the parking brake is set.
- b. Attach bonding/grounding reels.
- c. Use the fuel pump to empty tank contents into a safe container.
- d. Open low point sump valve (3) to allow remainder of fuel to drain.
- e. Open petcock drain (1) on filter to drain fuel from filter housing.
- f. Remove pipe plug (2) to drain fuel from plumbing system.

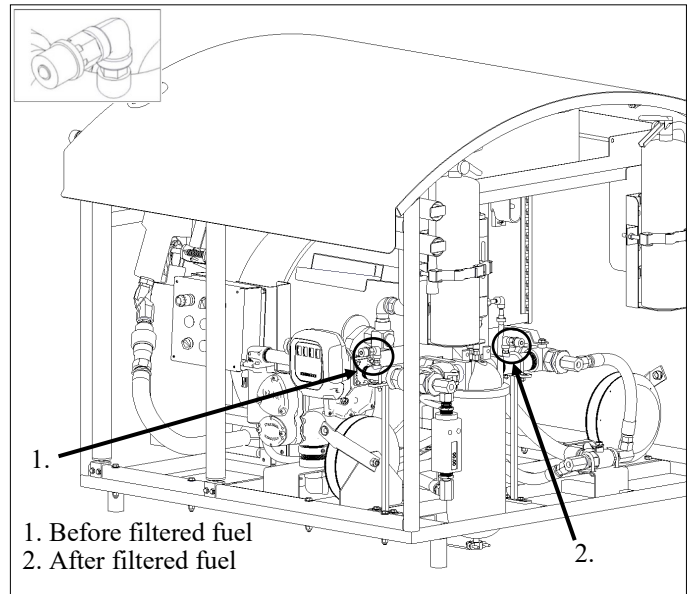

Figure 3-2 Sample Ports

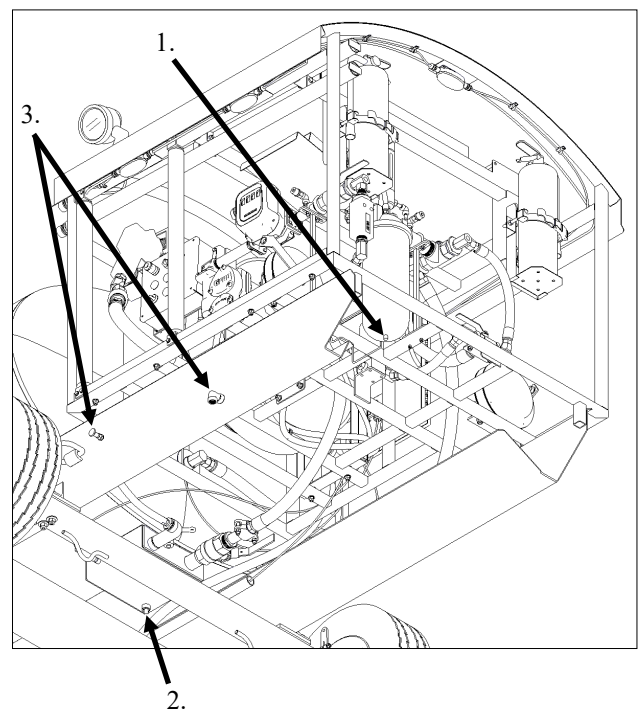

Figure 3-3 Plumbing Drain Ports

SECTION 4.0

MAINTENANCE, ASSEMBLY AND REPAIR

The UAS Cart should always be inspected prior to use to make sure it is in working order.

4.1 Repair and Replace Instructions

Remember to set the parking brake while performing maintenance procedures. Approved jack stands and wheel chocks must also be used. Serious injury or death may occur from rolling or falling equipment.

The following procedures are used for the disassembly and reassembly for equipment components.

4.2 General Tank Instructions

⚠ WARNING

Make sure that the tank is free of fuel and flammable and/or combustible vapors before performing any maintenance operation involving the tank. Serious injury or death could occur.

This procedure covers all components attached to the tank by means of threaded pipe connections and describes how to properly apply pipe joint sealing compounds. Pipe joint sealing compounds should be approved for fuel service.

- a. Remove parts that need to be repaired or replaced.
- b. Remove old pipe sealing compound from component (s) by wire brush or approved solvent. If solvent is used, allow parts to dry before moving on to step c.
- c. Inspect threads, and replace any damaged parts.
- d. Apply an even coat of pipe joint sealing compound across and all around the first four threads. The coat thickness should fill the thread “valleys”, and no more.
- e. Tighten until hand-tight. Do not cross thread components.
- f. Tighten parts until the connection is leak free.

4.3 Manway Assembly and Maintenance

The manway assembly is located on the top of the tank. The manway assembly has one adjustment point. Use Figure 4-1 for the following maintenance steps.

Manway Disassembly/Reassembly

- a. Open handle (2).
- b. Open Manway Assembly.
- c. Remove nut (7).
- d. Remove gasket retainer (5), gasket (4), and lid (3).
- e. Remove bolt (6) and nut (10) to remove cross-arm (1).
- f. Repair / replace components
- g. Reassemble in reverse order, leaving nut (7) only partially threaded onto cross arm (1).

Manway Adjustment

- a. Open handle (2).
- b. Open Manway Assembly.
- c. Rotate nut (11) to adjust lid position. Turn clockwise to move lid closer to the tank. Turn counter clockwise to move the lid away from the tank.
- d. Tighten nut (7) until snug.

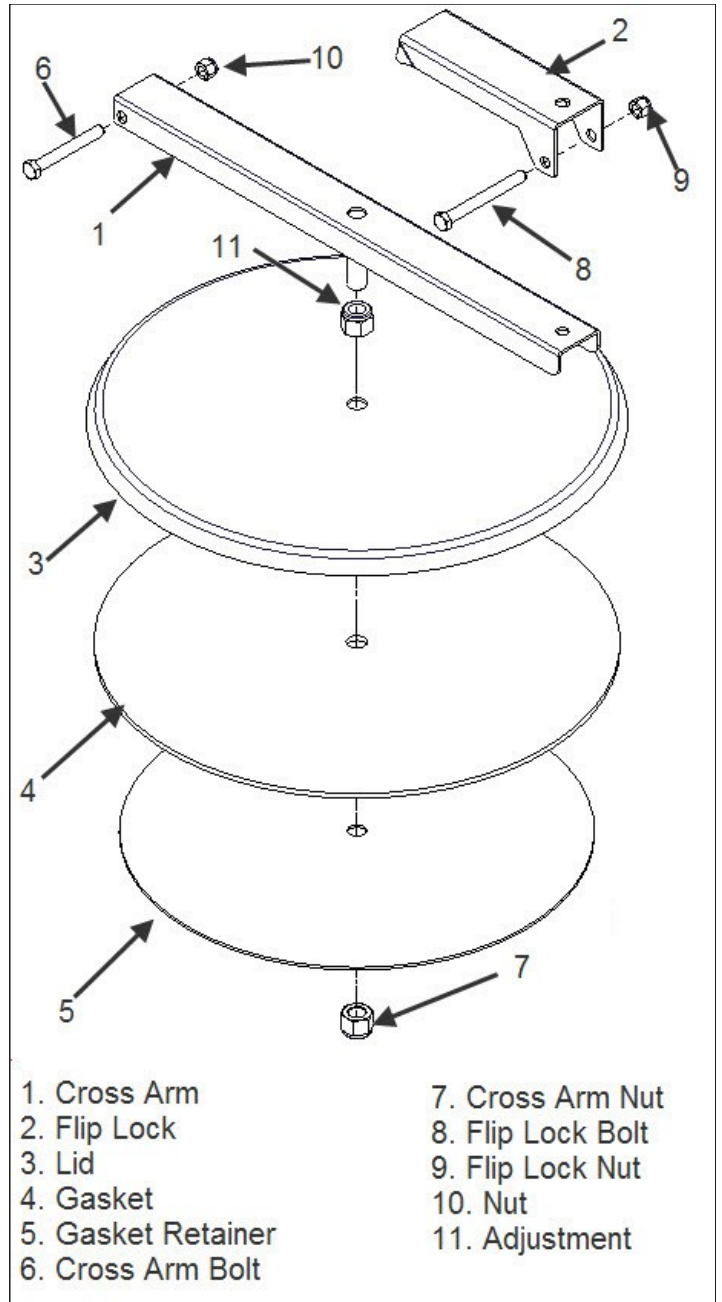

Figure 4-1 Manway Assembly

4.4 Front Undercarriage Assembly

The Front Undercarriage assembly consists of a wheel assembly, a hub assembly a spindle assembly a tow latch assembly, a steering arm assembly and an adjustable tie rod assembly.

4.5 Front Wheel Assembly Removal

To remove the wheel assembly, the equipment must have the front end raised and placed on approved jack stands.

- Loosen lug nuts on wheel assembly requiring maintenance one turn while equipment is still on the ground.
- Raise equipment with suitable maintenance jack (See Figure 4-2, arrow A for jack placement) high enough to remove wheel assembly.
- Place approved jack stands under front axle (See Figure 4-2, arrow B for stand placement).
- Remove lug nuts of wheel assembly needing maintenance, and remove wheel.

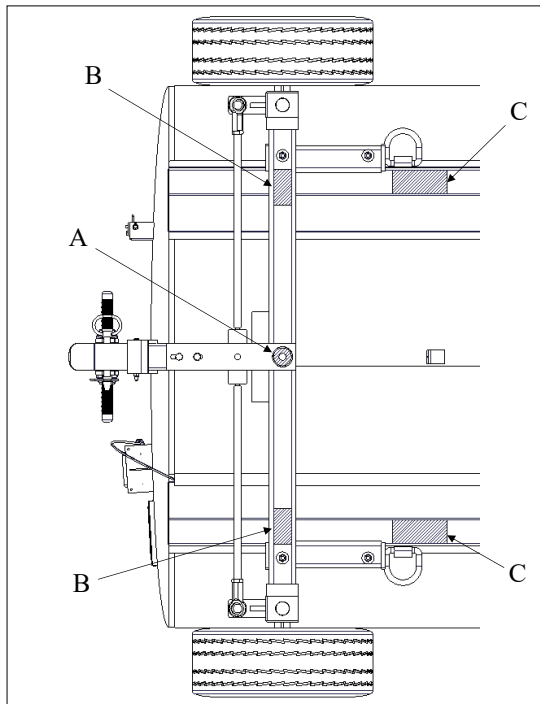

Figure 4-2 Lift Points

4.6 Front Hub Assembly

To remove the front hub assembly, follow these maintenance steps. (See Figure 4-3)

- Remove dust cap (1) by lightly taping with a rubber hammer.
- Remove cotter pin (2), castle nut (3), and washer (4).
- Grasp front hub (7) and pull outward firmly. Ensure that bearing (5) doesn't fall from hub and strike the ground.
- Remove bearing (5), seal (10), and bearing (9) from the front hub (7). Using a suitable H-frame press, remove bearing races (6) and (8).
- Replace components and grease bearings before reassembly.
- When reassembling, Castle nut (3) should be tightened until the hub assembly rotates past free.

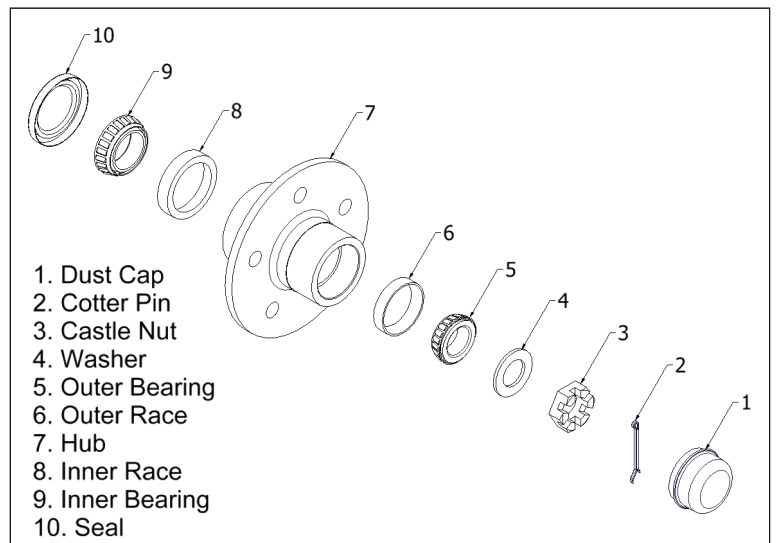

Figure 4-3 Front Hub Assembly

4.7 Tow Latch Assembly

The tow latch assembly is used to secure the tow bar in the upright position. (See Figure 4-4)

- a. Remove tow bar (1) by placing the tow bar in upright, latched position. Pull the hitch pin (2). While holding onto tow bar, place foot on toe latch assembly (See reference arrow A) and depress.
- b. Pull hitch pin cotter (3) from steering arm assembly and place tow bar to the side.

(The remaining steps are illustrated in Figure 4-5)

- c. Remove nut (10) and bolt (7).
- d. Rotate toe latch plate (9) downward to free from assembly.
- e. Detach spring (8) from toe latch plate (9) and spring anchor (24).

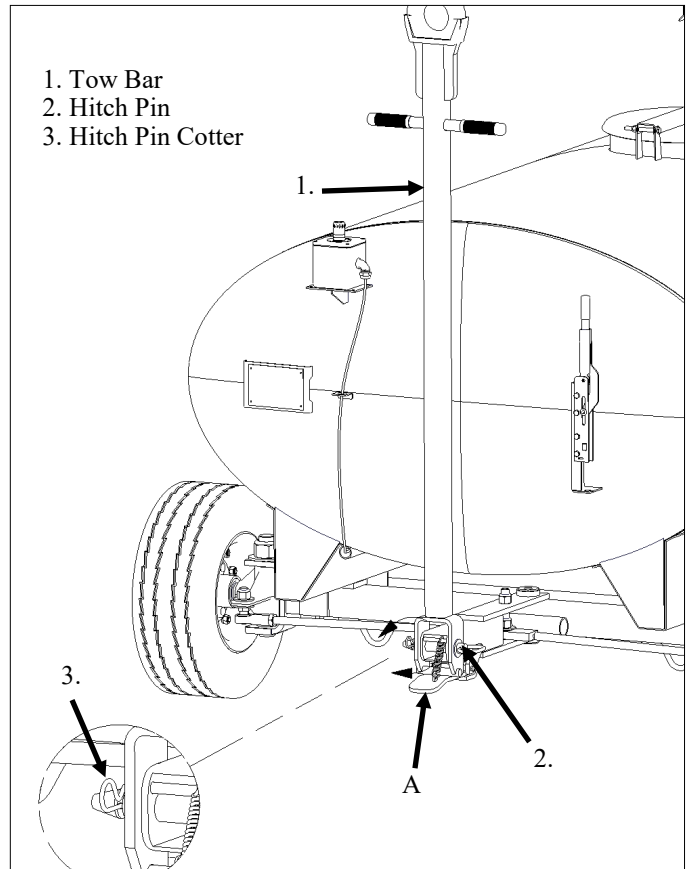

Figure 4-4 Tow Bar Removal

⚠ CAUTION

Removing hitch pin from steering arm assembly will free tow bar. Prevent tow bar from falling by holding it firmly until free. Set aside.

4.8 Spindle Assembly

To remove the spindle assembly, follow the maintenance steps for the front hub assembly before beginning the next steps. (See Figure 4-5).

- a. Remove nut (17) and washer (16).
- b. Remove nut (21) and washer (20).
- c. Remove king pin (14) from yoke by using a rubber hammer.
- d. Grasp spindle assembly (18) and rotate toward front of tank until the yoke is free.
- e. Remove spindle assembly from tie rod (15).
- f. Remove bushings (19) with bronze punch and hammer.
- g. Repair / replace components.

4.9 Steering Arm Assembly

- a. Remove the thin lock nut (1).
- b. Remove nuts (17) and flat washers (16).
- c. Remove bolts (22) and nuts (5). Allow lower steering arm subassembly (11), bushing (3), and tie rod assembly (12) to drop down; place to the side.

- d. Lift upper steering arm subassembly vertically to clear pivot pin (reference arrow (A)), then pull to clear tank and front axle tube.
- e. Remove tie rod assembly (12) by removing nut (6) and flat washer (4). Note the presence of the bushings (23).
- f. Repair / replace components.

4.10 Tie Rod Assembly

Refer to Figure 4-5 for the removal of the tie rod. Before beginning this process make sure that you have followed the steps for the steering arm assembly. **Note presence and location of bushings (23) when removing tie rod assembly from steering arm assembly.**

- a. Disassemble the tie rod assembly by the unthreaded components. Before disassembly mark rod length with masking tape.
- b. Adjust tire toe in/toe out as needed.

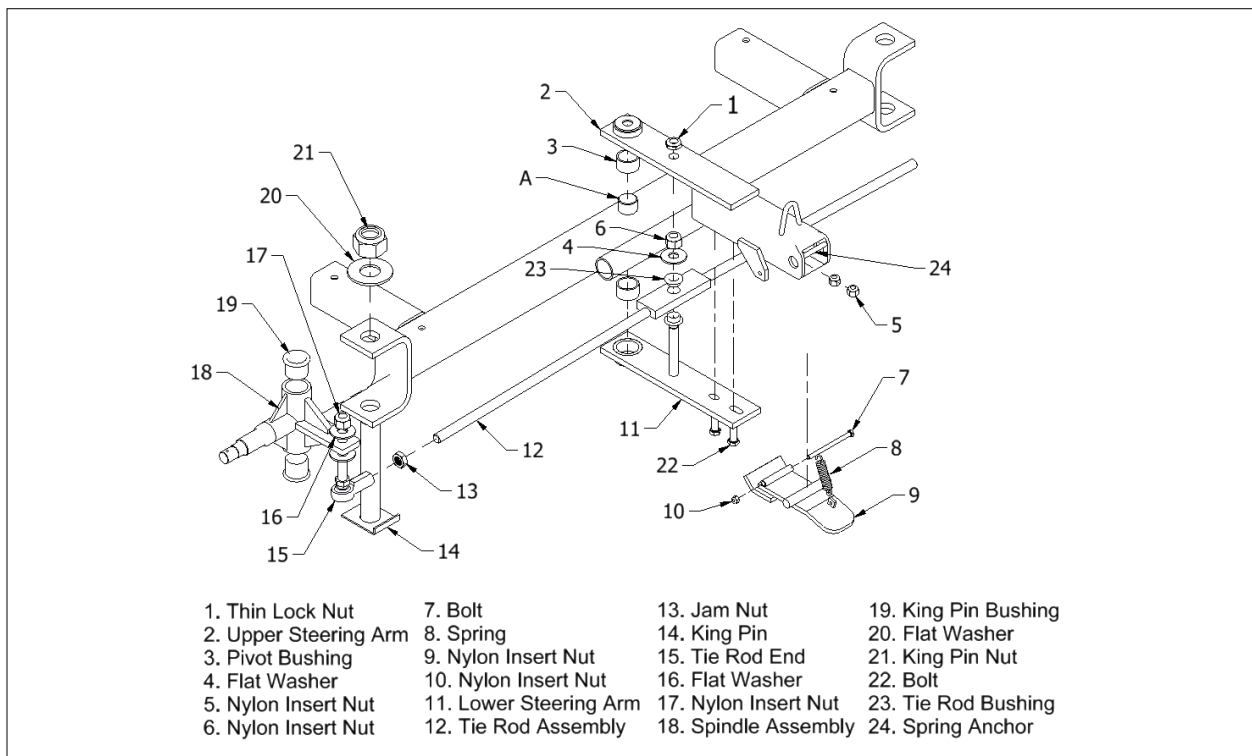

Figure 4-5 Exploded View of Undercarriage

4.11 Front Undercarriage Removal

To remove the entire Front Undercarriage assembly, the equipment must have the front end raised. See Figure 4-2 for lift points.

- Raise equipment with suitable maintenance jack (See Figure 4-2 arrow A for jack placement) to allow two inches of space between the wheels and ground.
- Place cribbing under tank skirts (See Figure 4-2, reference arrows C) to safely support the equipment.
- Lower onto cribbing. Leave jack in place.
- Raise jack to apply slight pressure on assembly. (**Tow bar must be in upright position.**)
- Remove bolts (3) and nuts (2), (See Figure 4-6).
- Carefully lower jack and assembly until wheels are on the ground and front axle tube clears tank mounts.
- Pull Front Undercarriage forward. Note location of rubber mounting pads (5).

▲WARNING

Use suitable lifting and support equipment when performing these steps. Serious injury or death could occur from rolling or falling equipment.

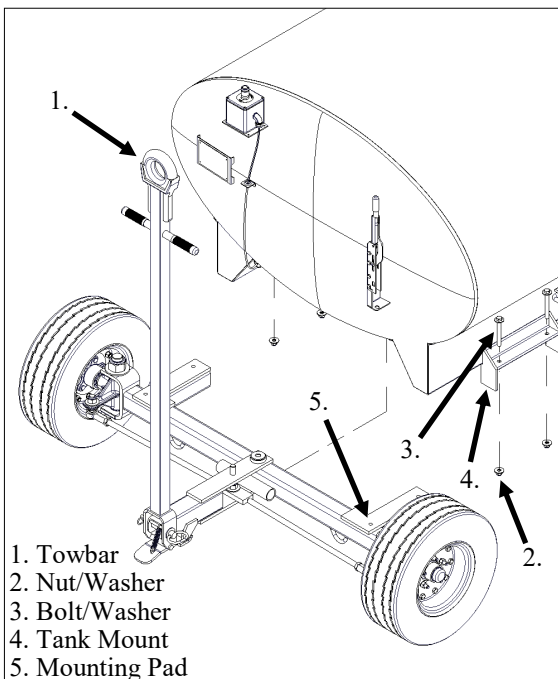

Figure 4-6 Front Undercarriage Removal

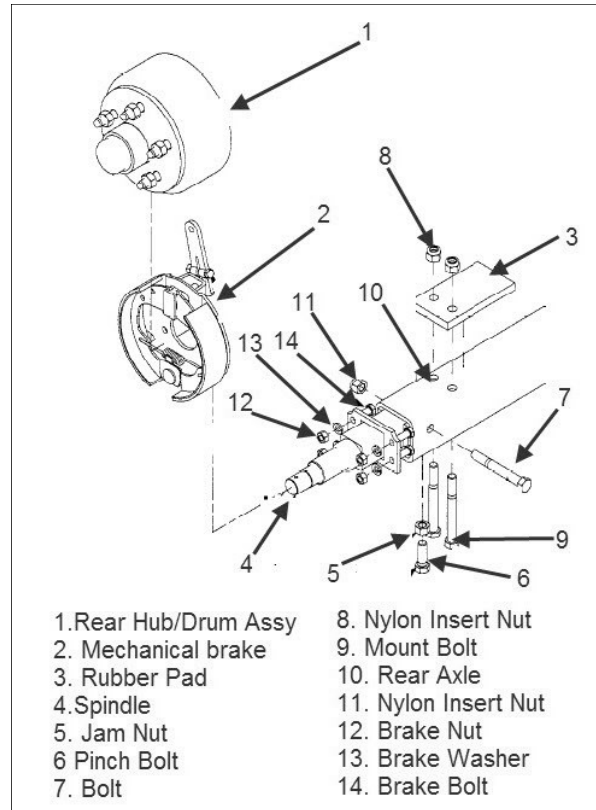

Figure 4-7 Rear Undercarriage Removal

4.12 Rear Undercarriage Assembly

See Figure 4-7 for the following maintenance steps. The rear undercarriage assembly consists of: a wheel assembly, a hub and brake drum assembly (1), a mechanical parking brake assembly (2), a rear spindle (4), and the axle (10).

4.13 Rear Wheel Assembly Removal

To remove wheel assembly, the equipment must have the back end raised and placed on approved jack stands. Points A and B are similar on both the rear and front axles. (See Figure 4-2)

- Raise equipment with suitable maintenance jack high enough to remove wheel assembly. (See Figure 4-2, arrow A for jack placement).
- Place approved jack stands under rear axle (See Figure 4-2, arrow B for stand placement).
- Remove lug nuts of wheel assembly needing maintenance.

4.14 Rear Hub / Brake Drum Assembly

To remove the rear hub and brake drum assembly, follow the maintenance steps for the rear wheel assembly removal before beginning the next steps. Figure 4-8 illustrates the process for the rear hub/ brake drum assembly.

- a. Remove dust cap (1) by lightly tapping with a rubber hammer.
- b. Remove cotter pin (2), castle nut (3) and washer (4).
- c. Grasp front hub (7) and drum (8) and pull outward firmly. Ensure that bearing (5) doesn't fall from hub and strike the ground.
- d. Remove bearing (5), seal (11), and bearing(10) from the rear hub (7).
- e. Using a suitable H-frame press, remove bearing races (6) and (9).
- f. Remove drum (8) by pressing out wheel studs (12) in suitable H-frame press.
- g. Replace components and grease bearings before reassembly.
- h. Reassemble in reverse order. Castle nut (3) should be tightened until the hub assembly rotates barely past free.

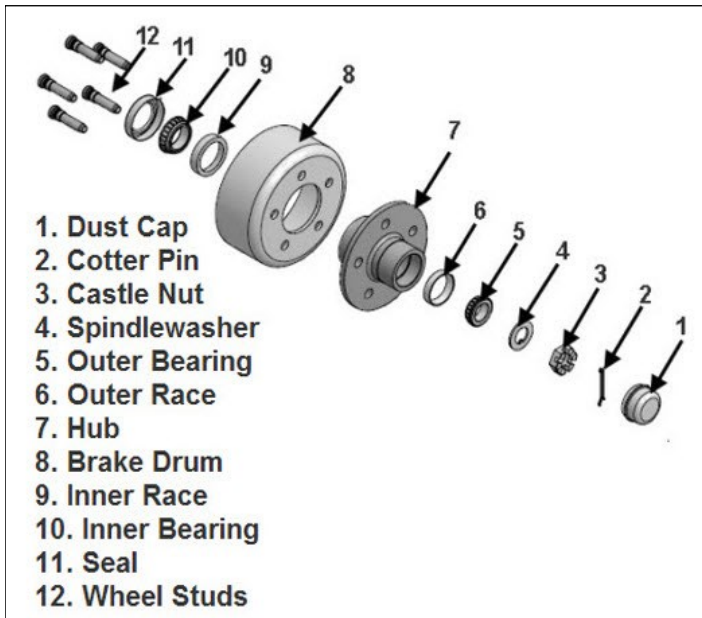

Figure 4-8 Rear Hub and Brake Drum

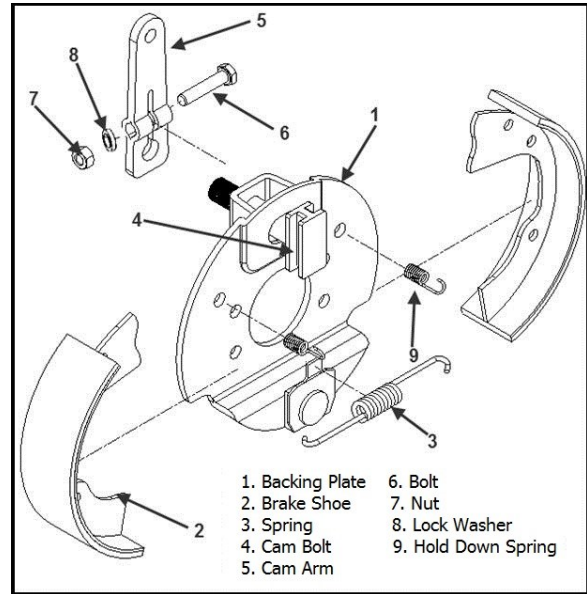

Figure 4-9 Mechanical Brake

4.15 Mechanical Brake Assembly

The assembly can be disassembled while attached to the rear spindle or removed from the unit. (See Figure 4-9)

NOTE: Steps (d) and (e) are needed only if Mechanical Brake Assembly is to be removed from the axle.

- a. Remove Rear Wheel Assembly as described in section 4.13.
- b. Remove Rear Hub and Brake Drum Assembly as described in section 4.14.
- c. Remove brake cable end from arm (5) as described in Section 4.17, step (a).
- d. Remove nuts (16), washers (17), and bolts (18) shown in Figure 4-10.
- e. Remove Mechanical Brake Assembly and place on flat surface.
- f. Remove spring (3).
- g. Release brake shoes (2) by removing spring (9) from the backing plate (1).
- h. Remove nut (7), lock washer (8), and bolt (6) to release arm (5).
- i. Remove brake cam bolt (4) by pulling directly outward.

4.16 Parking Brake Assembly and Adjustment

The parking brake assembly consists of a brake handle and cable assembly and a mechanical brake assembly. The parking brake can be adjusted at three different locations.

An in-field adjustment can be made at the brake handle by turning the handle cap clockwise to tighten brakes and counterclockwise to loosen the brakes (see reference arrow D in Figure 4-10.) This adjustment must be made with the brake handle in the off position. Maintenance level adjustments can be made at reference arrow E and reference arrow F of Figure 4-10 (each side).

4.17 Brake Handle and Cable Assembly

The brake handle and cable assembly only need to be disassembled to the point that the repair is needed. These instructions start at the wheel assembly and progress toward the brake handle (1). (Figure 4-10)

- Remove cotter pin (13) and clevis pin (14) to release clevis (12).
- Unthread clevis (12) from cable
- Remove nut (15) and remove cable housing (10) from bracket.
- Remove nut at opposite end of cable and disassemble cable linkage parts (6), (7), (8), and (9).
- Repeat steps (a) through (d) for opposite side.
- Remove nut (4) to release cable equalizer (5).
- Repeat step c. for cable housing leading to brake handle.
- Remove nut at other end of cable and release cable by disassembling cable linkage from brake handle (1).
- Remove bolts (2) and nuts (3) to free brake handle (1).

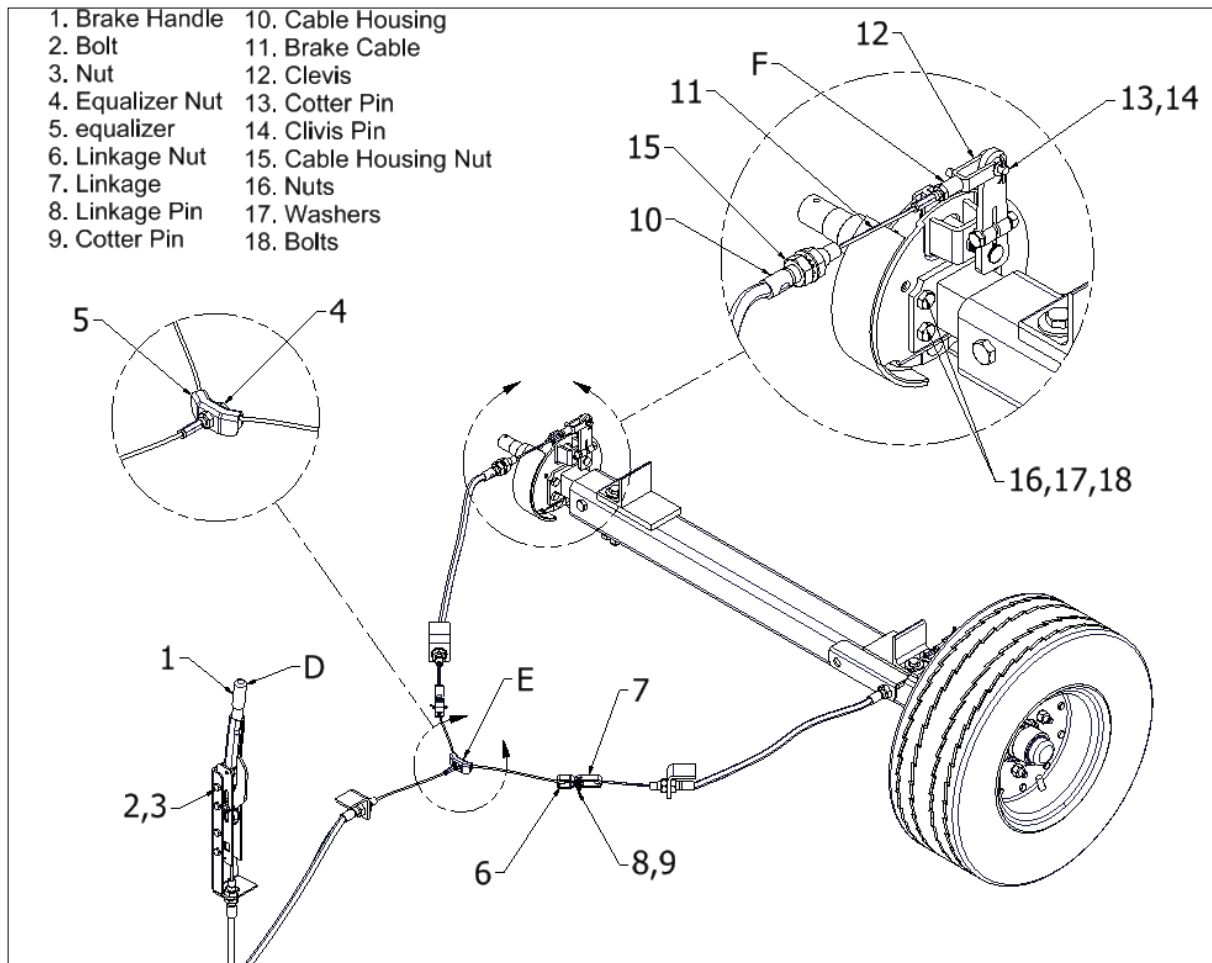

Figure 4-10 Brake and Cable Assembly

4.18 Rear Undercarriage Assembly Removal

To remove the entire Rear Undercarriage assembly, the equipment must have the back end raised. See Sections 4.12, and 4.13 with Figure 4-11.

- Raise equipment with suitable maintenance jack (see Figure 4-11 reference arrow A for jack placement) and allow for two inches of space between the wheels and the ground.
- Place cribbing under tank skids to safely support the equipment. (See Figure 4-11, reference points labeled with a C).
- Lower onto cribbing. Leave jack in place.
- Disconnect parking brake cables at mechanical brake assembly in Section 4.15, step (a).
- Raise jack to apply slight pressure on assembly.
- Remove mounting nuts and bolts from both sides of axle assembly.
- Carefully lower jack and assembly until wheels are on the ground and the front axle tube clears tank mounts.

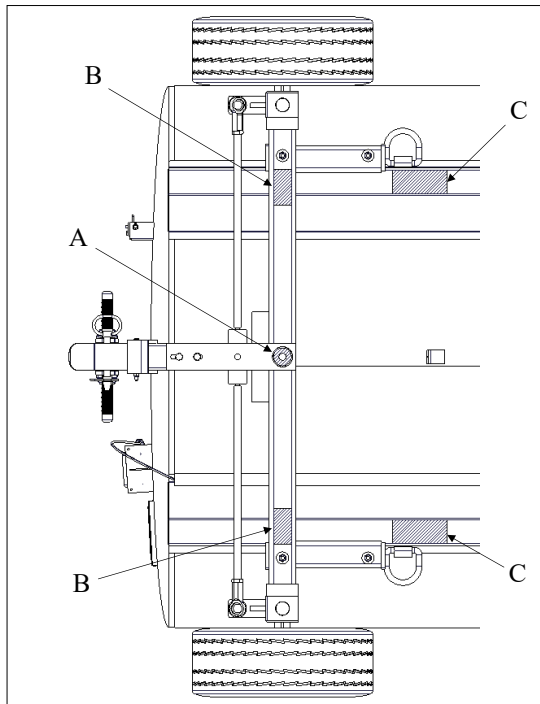

Figure 4-11 Lift Points

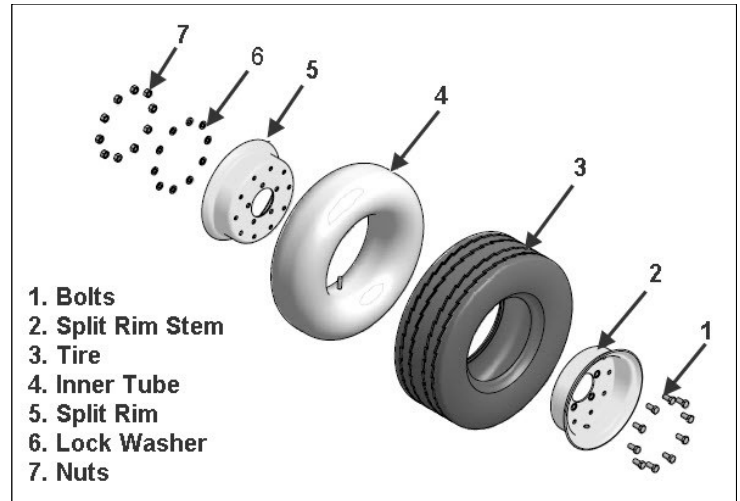

Figure 4-12 Wheel Assembly

4.19 Wheel Assembly

The Wheel assembly is a two-piece, split rim design. Use Figure 4-12 and sections 4.12 and 4.13 for the following maintenance steps.

- Remove wheel assembly as described in Section 4.5 for the side needing repair.
- Release air pressure from the inner tube by depressing stem valve or by removing the stem valve.
- Remove nuts (7), lock washers (6), and bolts (1).
- Separate split-rims (2) and (5) from tire (3).
- Remove inner tube (4) from tire (3). When reassembling, make sure that the inner tube stem is positioned through access hole in split-rim.
- Torque split rim nuts (7) to 75-foot-pounds before applying air pressure to tire.
- Torque lug nuts to 100-foot-pounds.

⚠ WARNING

Disconnect all electrical connections to the unit (batteries, battery charger, tow vehicle) before performing any of the steps described here. Flammable liquids and vapors can be ignited by accidental electrical arcs. Serious injury or death could result.

Drain all flammable liquids from the tank and plumbing system before performing any of the steps described here. Flammable liquids and vapors pose a fire danger that could result in serious injury or death.

4.20 Removing the Fuel Pump

(See Figure 4-13 for the following maintenance steps)

- a. Remove electrical leads from pump motor. The cover plate is located in back of the pump motor and the conduit is located in front of the pump motor.
- b. Remove the four bolts connecting the fuel meter (6) to the pump-to-meter line (9).
- c. Remove the pump to meter line (9).
- d. Remove the four bolts at the bottom of the pump mounting plate.
- e. Remove the threaded hose from the pump's inlet.

4.21 Removing the Fuel Meter

- a. Remove the four bolts connecting the fuel meter (6) to the pump-to-meter line (9).
- b. Remove the four bolts connecting the fuel meter (6) to the pump.

4.22 Removing the Filter Housing

- a. Remove the Victaulic fitting on the left side of the housing filter.
- b. Unthread the recirc. valve (8).

4.23 Removing the Hose Reel

- a. Remove all items connected to nozzle holder bracket (14) and remove bracket.
- b. Remove valve-to-reel line. (13)
- c. Remove the quick disconnect from the fueling nozzle (3).

4.24 Removing Defuel Pump

(See Figure 4-14 for the following maintenance steps)

- a. Remove the threaded hose from the pump's inlet and outlet.
- b. Unscrew mounting bolts connecting the pump to the pump bracket.
- c. Pump electrical connection is wired to the electrical box. First, unscrew plexiglass and remove.
- d. Follow wire to electrical box and unscrew wire from terminal block inside box. Then, loosen conduit connection on bottom of box.

4.25 Removing Defuel Meter

(See Figure 4-14 for the following maintenance steps)

- a. Remove threaded hose from bottom of meter.
- b. Remove threaded connection from top of meter.

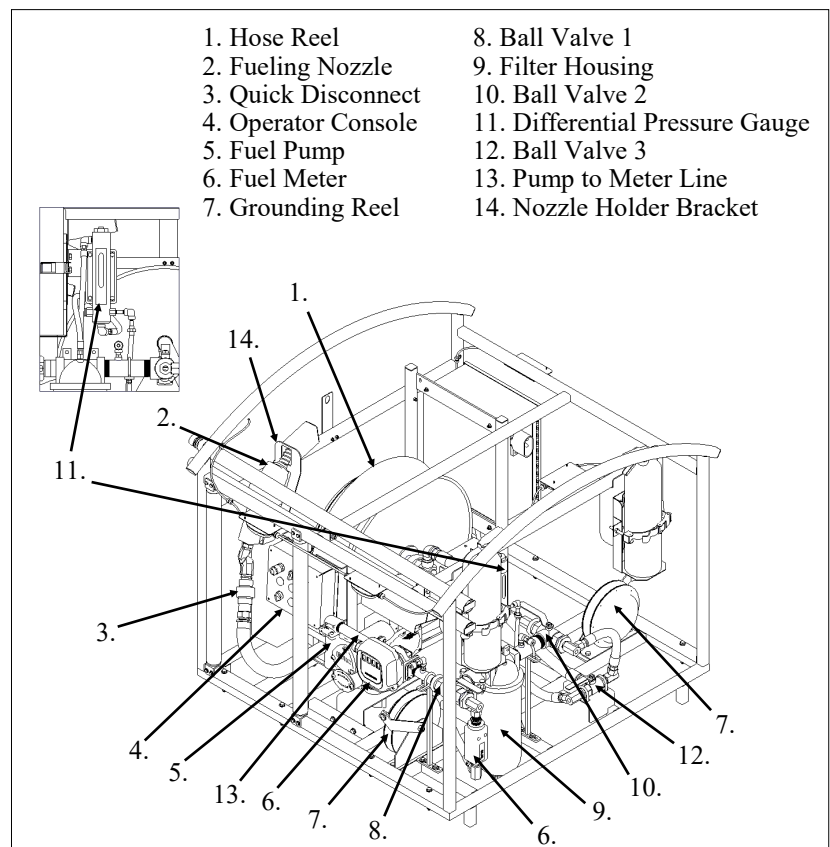

Figure 4-13 Pump Module

4.26 Changing Fuel Filter Element

The fuel filter element should be replaced whenever fuel flow is restricted and differential pressure reads 15psi or greater (red zone), or at least once per year. The following steps describe how to replace the fuel filter. (See Figure 4-15)

- a. Drain filter housing by opening the top and bottom petcock valves.
- b. Remove the four bolts that secure the filter canister to the filter housing.
- c. Pull downward on the filter element.
- d. Replace O-ring (not shown.)
- e. Install new filter element in reverse order.
- f. Close bottom petcock valve.
- g. Jog pump to purge air.
- h. Close top petcock valve.

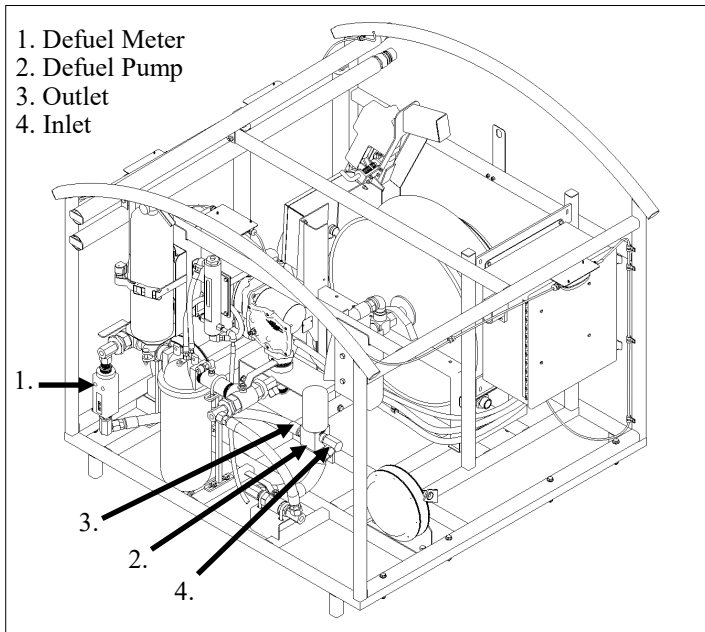

Figure 4-14 Pump Module Continued

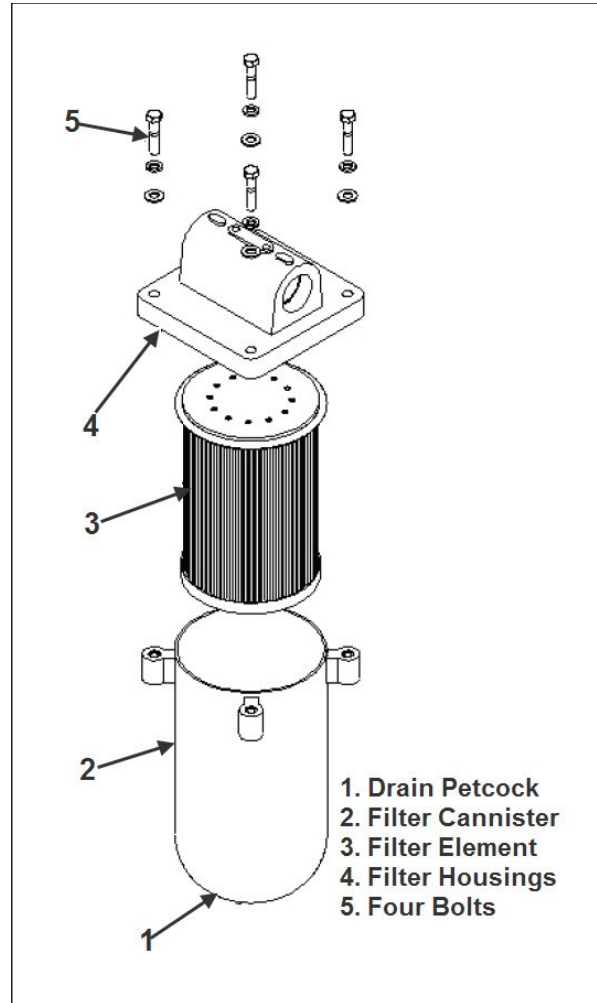

Figure 4-15 Fuel Filters

MAINTENANCE

NOTE: This pump is designed for minimum maintenance. The motor bearings are self-lubricating. Inspect the pump and components regularly for fuel leaks and make sure the hose and power cord are in good condition. Keep the pump exterior clean to help identify leaks.

IMPORTANT: Do not use this pump for water, chemicals or herbicides. Dispensing any fluid other than those listed in this manual (see **BEFORE YOU BEGIN: Fueling Requirements** at front of manual) may damage the pump. Use of the pump with unauthorized fluids will void the warranty.

Clean or Replace Check valve / Strainer

1. Turn the pump off and disconnect from power. Using 6mm hex wrench, remove the strainer access cover, O-ring, and check valve/strainer assembly and inspect for damage or clogs (see Figure 11). Clean the strainer with a soft-bristled brush and solvent. If the strainer is very dirty, compressed air may be used. If damaged, replace the check valve/strainer assembly.
2. Clean the strainer access cover and O-ring. Coat the O-ring lightly with grease. Reinstall the check valve/strainer, O-ring and strainer access cover. Ensure the O-ring is properly seated and tighten securely.



Figure 4-16 Clogged Pump Strainer

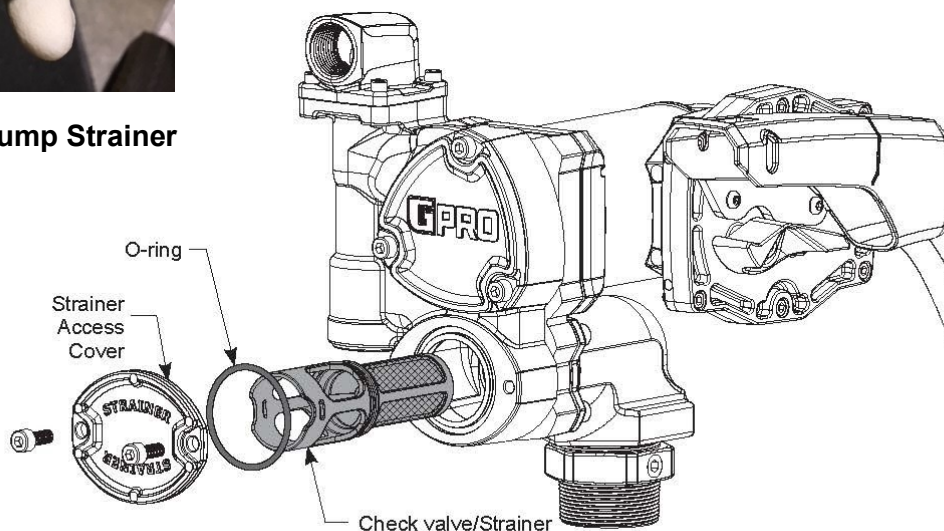

Figure 11

Figure 4-15 Manufacturer's Pump Strainer Removal
(GPI MODEL V25-24PX Fuel Pump)

4.28

Troubleshooting the UAS Cart

Problem	Probable Cause	Corrective Action
Threaded Connection leaking weeping	Loose fitting, bad seal, damaged fitting	Use Section 4.2 To fix condition
Valve Leaking, weeping, or doesn't operate	Internal damage to valve's ball, stem, or seat	Replace valve using section 4.2
Manway won't seal	Manway Assembly is out of adjustment or seal is damaged	Adjust manway assembly using section 4.3
Low/ No discharge pressure at fuel nozzle	Low battery charge Fuel filter(s) restricted Tank-to-Pump valve partially open Pump strainer is blocked	Charge batteries Inspect and replace if needed, see section 4.26 Ensure valve is open (handle vertical) Inspect and replace if needed, see section 4.27
Low/ No Defueling Capability	Low battery charge Fuel filter restricted Tank-to-Pump valve partially open	Charge batteries Inspect and replace if needed Ensure valve is open (handle vertical)
24 Volt pump – weak or will not work	Low/ No battery charge Battery terminals/ cables corroded Battery Cell(s) fluid low Main Power switch in OFF position Pump has internal damage Pump has reached duty cycle Circuit breaker has tripped	Fully charge batteries Inspect & clean, replace if necessary Service cell(s) with distilled water Turn Main Power switch ON Replace pump Wait 30 minutes and retry Wait 30 minutes and retry
Fuel Meter(s) have no indication of flow	Pump not selected Selected pump not turned ON Main tank empty Fuel Meter internally broken	Turn switch to fuel or defuel Turn ON pump Load fuel into tank Replace fuel meter
Wheels won't steer properly	Steering arm assembly is damaged or tie rod assembly is damaged or misadjusted.	Inspect and repair when needed using Sections 4.9 and 4.10.
Wheels wobble or drag while rolling	Wheel bearings are damaged or loose	Inspect and Repair if needed using 4-5, 4-6 and 4-14.
Towbar won't lock in upright position	Tow latch spring, damaged or missing	Inspect and replace when necessary
Brakes don't secure unit while engaged.	Brakes are out of adjustment parking brake assembly is damaged or missing	Adjust brakes or adjust and repair using sections 4.15, 4.16 and 4.17.

SECTION 5.0

PART BREAKDOWN DRAWINGS AND PART NUMBERS

The following figures are supplied to assist in component identification and parts reordering. When reordering, ensure the complete model number and serial number are provided to the sales representative.

You may access customer service by contacting Spokane Stainless Technologies, Inc. at 509-921-8850. If you would like more information about Spokane Stainless Technologies, Inc., you may visit the website at

www.spokanestainless.com

DRAWING NUMBER

- 1.0 Overview, Component Identification**
- 2.0 Pump Components**
- 3.0 Manway Assembly**
- 4.0 Front Undercarriage**
- 5.0 Rear Undercarriage and Axle**
- 6.0 Front Hub Assembly**
- 7.0 Rear Hub & Drum Assembly**
- 8.0 Wheel & Tire Assembly**

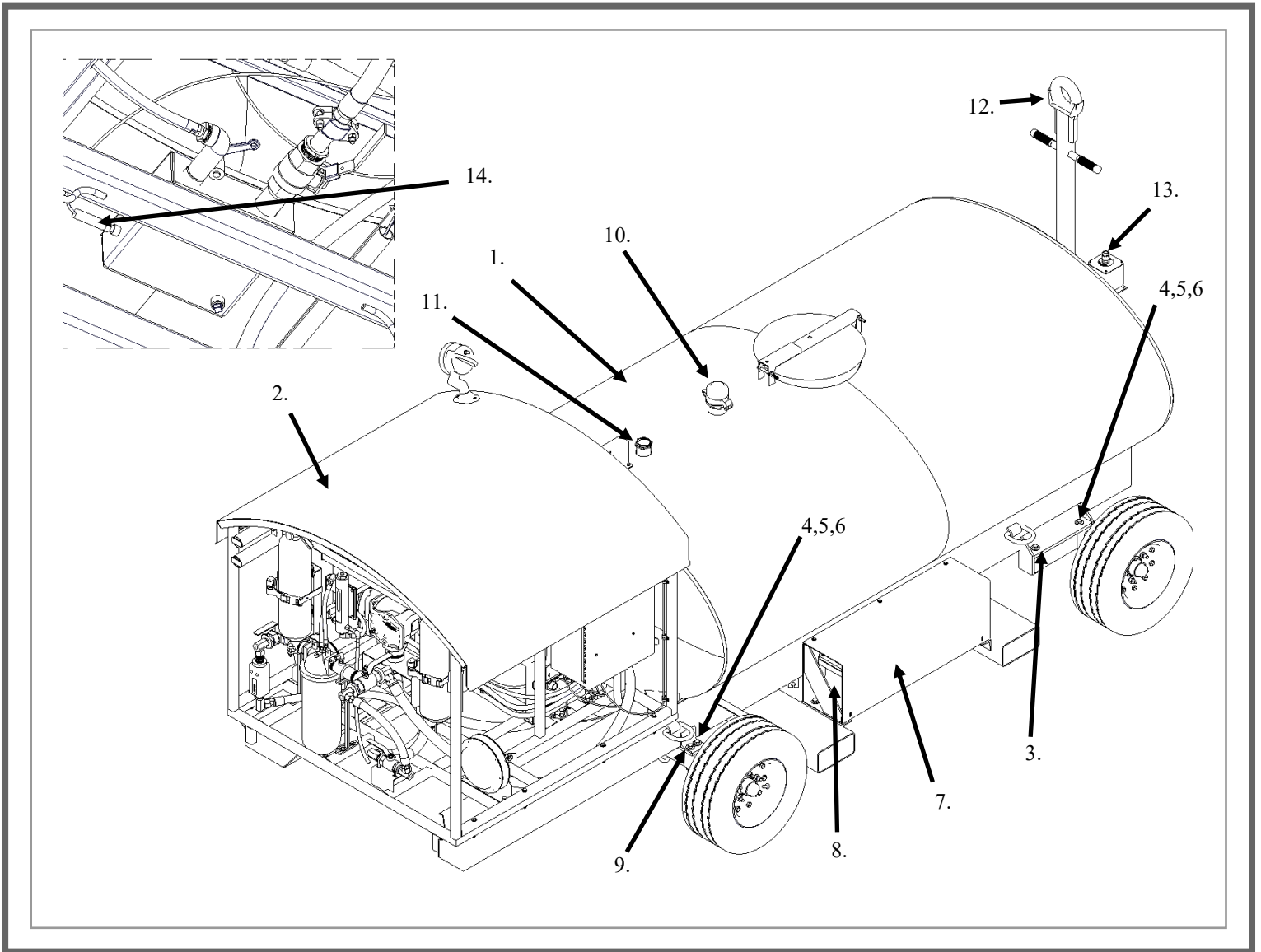

DRAWING 1.0

Overview Component Identification

-Not Illustrated

ITEM	QTY	P.N.	DESCRIPTION	MATERIAL	WEIGHT
1	1	07-9038	Tank Weldment 600 Gallon	Various	1852 lb
2	1	25-0004	Pump Module Assembly	Various	788 lb
3	2	06-1023	Front Mounting Pad	Rubber	1 lb
4	8	02-3025	Capscrew, 1/2-IN x 4-1/2-IN LG	Stainless Steel	0 lb
5	16	02-3125	Washer, 1/2-IN	Stainless Steel	0 lb
6	8	02-3087	Nut, Nylon Insert, 1/2-IN-13	Stainless Steel	0 lb
7	1	07-5510	Dual Battery Enclosure	Various	48 lb
8	2	04-8050	Battery 12V	Various	60 lb
9	2	06-1012	Rear Mount Pad	Rubber	0 lb
10	1	04-01545	Tank Vent / Fill Cap, 2-IN	Aluminum	0 lb
11	1	04-8007	Liquid Level Gauge	Various	0 lb
12	1	07-1103-1	Weldment, Tow Bar	Mild Steel	34 lb
13	1	105-00004-A023	E-Stop Assembly	Various	6 lb
14	1	04-0026	Water Detection Sensor, 1/4-IN -18 NPT	Various	0 lb
-15	1	08-1810-1	Adapter, #8 HYD BY 1/2-FPT	Various	2 lb

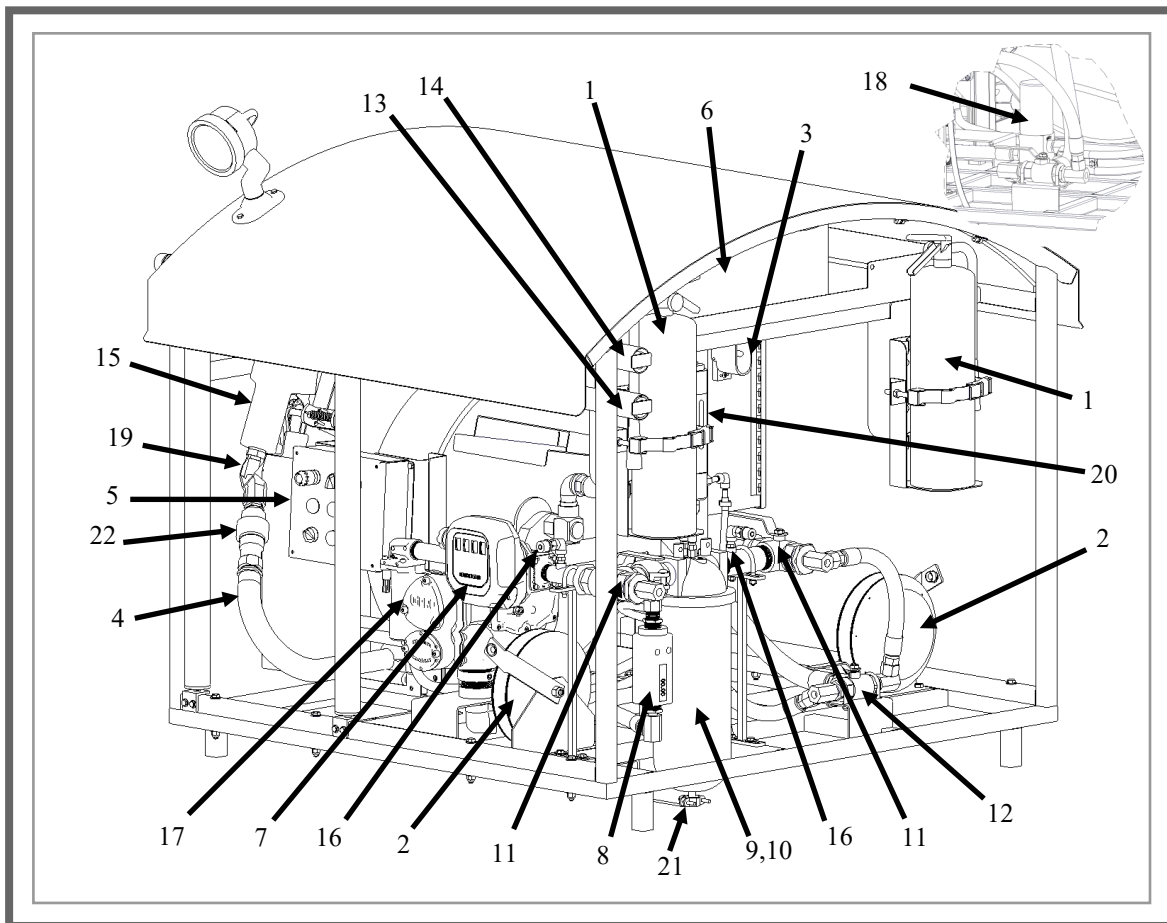

Drawing 2.0 Pump Components

ITEM	QTY	P.N.	DESCRIPTION
1	1	04-0702	Fire Ext. 10 lb Purple K
2	2	04-10362	Grounding Reel, Plug and Clamp, 75-FT
3	1	15-00158	Electrical Box Assembly With Battery Charger 120 Volt AC input/ 28 Volt DC dual output
4	1	25-5019	Hose Asm., 1-INCH x 50-FT, Goodyear Wingcraft
5	1	15-00163	Operator Console
6	1	04-8025	Spill Response Kit
7	1	04-8259	Fueling Meter, GPI Model QM-40 G8N
8	1	04-8071-1	Defueling Meter, GPI 03A Series
9	2	04-80192	Filter Housing, Velcon VF-61
10	1	04-8020	Filter Element, Velcon OS-51288, Coalescer/Separator Fits VF-61
11	2	04-10312	Valve, Ball, 3-Way, 1-1/2-INCH NPT
12	1	04-10081	Valve, Ball, 3-Way, 1-INCH NPT
13	1	25-0003-012	Weldment, Lower Storage Tube, Suction Wand
14	1	25-0003-013	Weldment, Upper Storage Tube, Suction Wand
15	1	04-8162	Nozzle, Automatic Shut-off .83-INCH, 1-IN FNPT
16	2	04-8040	Sample Port
17	1	04-8240-1	Pump, Fuel, 24VDC, 25GPM, 35 AMP
18	1	04-8079	Pump Defuel, 24VDC, 3 GPM, 10 AMP, Weldon Model D2025-B
19	1	04-0201	Swivel, Fuel Nozzle, 1-INCH NPT
20	1	04-8255	Differential Pressure Gauge, Gammon GTP-534
21	1	04-0469	Asm., Cable, Static Drain, Filter Housing to Grounding Reel
22	1	03-111396	QD Coupling, 1-INCH FNPT, Female

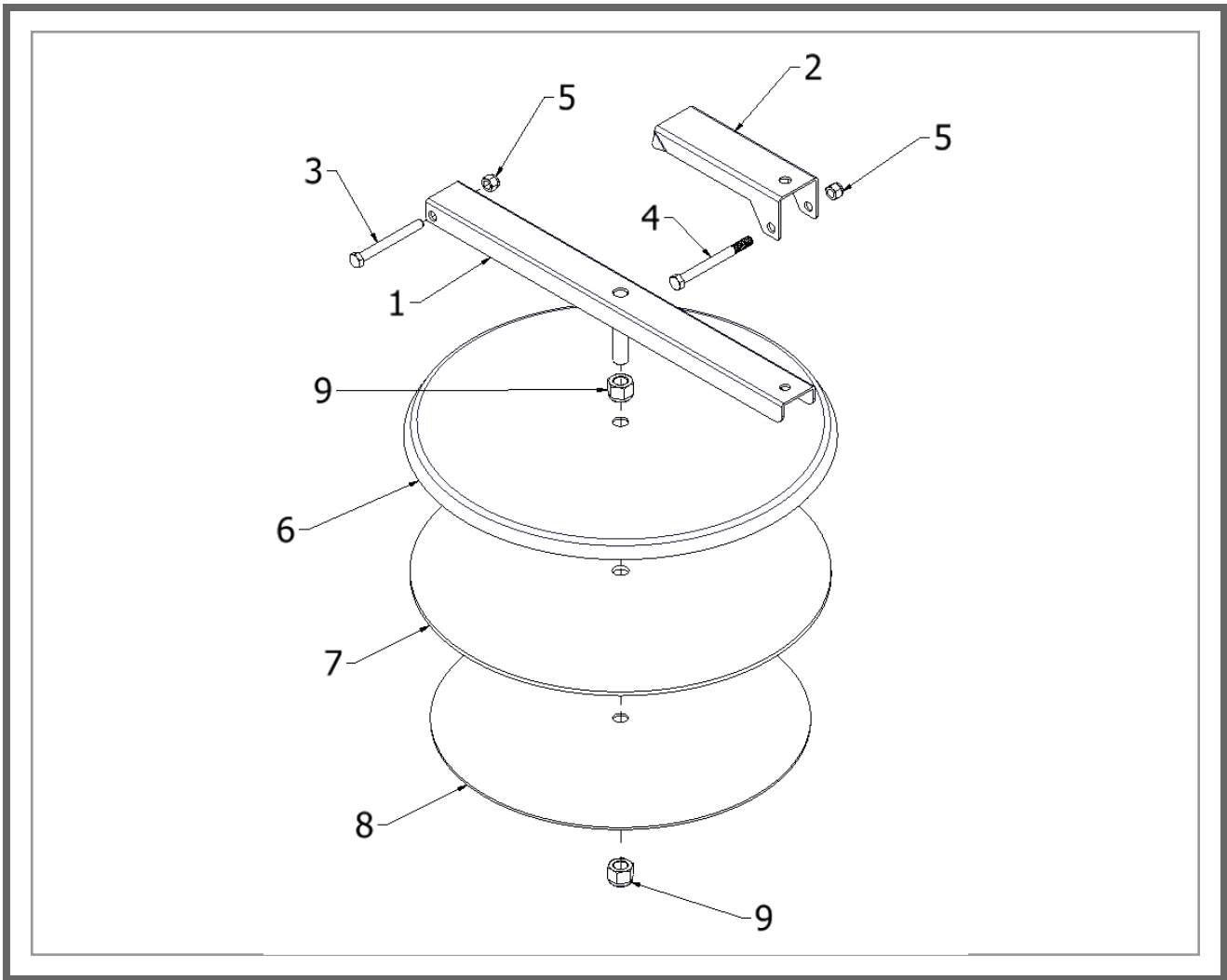

Drawing 3.0

Manway Assembly

ITEM	QTY	P.N.	DESCRIPTION
1	1	07-1039S	Cross Arm
2	1	01-8222S	Flip Lock
3	1	02-3044	Hex Hd. Capscrew, NC, 3/8" by 3-1/2" LG
4	1	02-3045	Hex Hd. Capscrew, NC, 3/8" by 4" LG
5	2	02-3089	Nut, Nylon Insert, 3/8-16 (AP)
6	1	01-86001	Manway Lid, 16" Diameter w/ Thru Hole
7	1	06-25025	Manway Gasket, 16" Standard, 3/16" Thk, Buna
8	1	07-2303	Retainer Gasket
9	2	02-3091	Nut, Nylock, NF, 5/8"-18

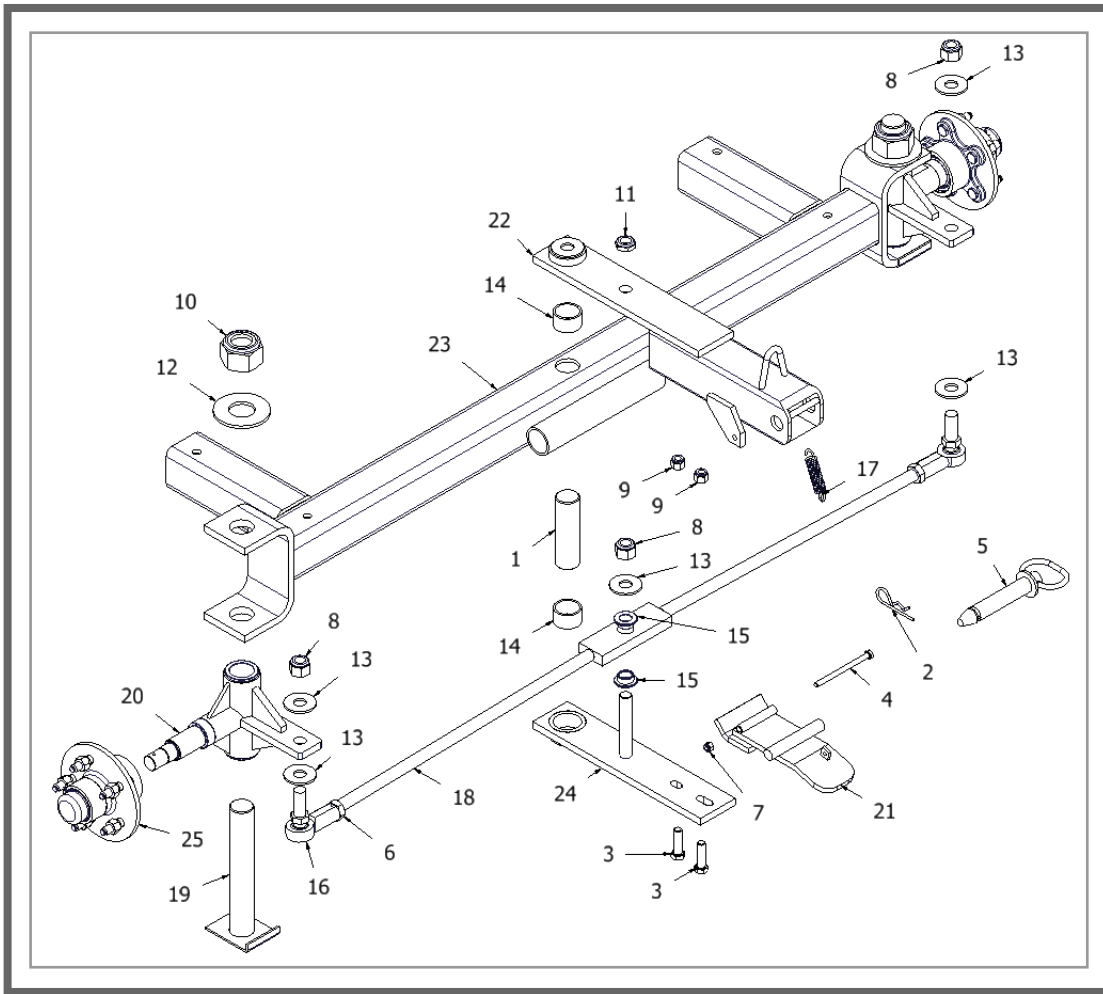

Drawing 4.0

Front Undercarriage

ITEM	QTY	P.N.	DESCRIPTION
1	1	01-8414	PIVOT PIN, FRONT AXLE
2	1	02-3016	HITCH PIN COTTER
3	2	02-3022	HEX HD CAPSCREW, NC, 1/2-IN BY 1 3/4-IN, GRD 5, PLATED
4	1	02-3055	HEX HD CAPSCREW, NC, 5/16-IN BY 4 1/2-IN LG, PLATED
5	1	02-3063	HITCH PIN, 1-IN BY 4 1/2-IN LG, PLATED
6	2	02-3081	NUT, JAM, UNF, 3/4-IN-16, PLATED
7	1	02-3082	NUT, NYLOCK, NC, 5/16-IN-18
8	3	02-3083	NUT, NYLOCK, NF, 3/4-IN-16
9	2	02-3087	NUT, NYLOCK, NC, 1/2-IN-13, FIN, PLATED
10	2	02-3093	NUT, NYLOCK, UNF, 1 1/2-IN-12, FIN
11	1	02-3094	NUT, NYLOCK, NF, 3/4-IN-16, FIN, THIN
12	2	02-3127	WASHER, FLAT, 1 1/2-IN, PLATED

ITEM	QTY	P.N.	DESCRIPTION
13	5	02-3131	WASHER, FLAT, 3/4-IN, PLATED
14	2	03-1014	BUSHING, STEERING ARM
15	2	03-1015	BUSHING, TIE ROD, PIVOT POINT
16	2	03-1016	ROD END, BALL JOINT LINKAGE
17	1	04-1054	SPRING, TOW LATCH
18	1	07-1005	TIE ROD ASSEMBLY, 400/600 GALLON
19	2	07-10105	KING PIN
20	2	07-1015	ASM., KING PIN
21	1	07-1020	TOW LATCH WMT, ALL SIZES
22	1	07-1104	STEERING ARM, UPPER, 400 & 600 GALLON
23	1	07-11071	FRONT AXLE WELDMENT, 400 & 600 GALLON
24	1	07-5002	STEERING ARM, LOWER PLATE, ALL SIZES
25	2	08-1011	FRONT HUB ASSEMBLY

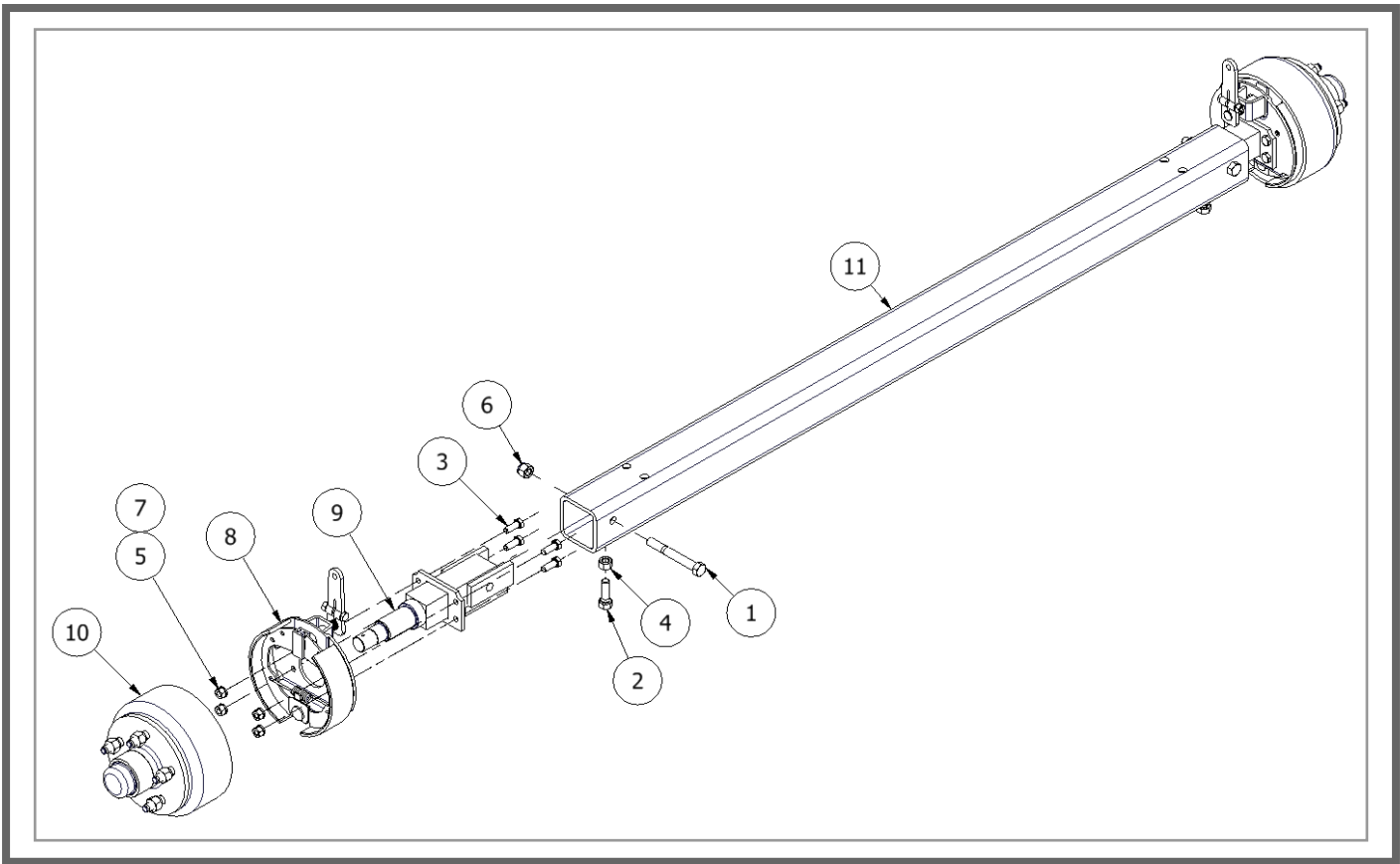

Drawing 5.0

Rear Undercarriage and Axle

ITEM	QTY	P.N.	DESCRIPTION
1	2	02-3024	HEX HD CAPSCREW, NC, 1/2-INCH BY 4-INCH, GRD 5, PLATED
2	2	02-3026	HEX HD CAPSCREW, NC, 1/2-INCH BY 1 1/2-INCH, GRD 5, PLATED
3	8	02-3050	HEX HD CAPSCREW, NC, 3/8-INCH BY 1-INCH, GRD 5, PLATED
4	2	02-3068	NUT, HEX, 1/2"-13 UNC PLATED
5	8	02-3072	NUT, HEX, NC, 3/8-IN-16, FIN., PLATED
6	2	02-3087	NUT, NYLOCK, NC, 1/2-INCH-13, FIN., PLATED
7	8	02-3143	WASHER, MEDIUM LOCK, 3/8-INCH PLATED
8	2	04-1063RBO	BRAKE ASSEMBLY
9	2	07-1010	REAR SPINDLE WELDMENT, REAR AXLE
10	2	08-10111	REAR HUB & DRUM ASSEMBLY
11	1	08-103011	REAR AXLE WELDMENT, 400 & 600 GALLON

- Not Illustrated

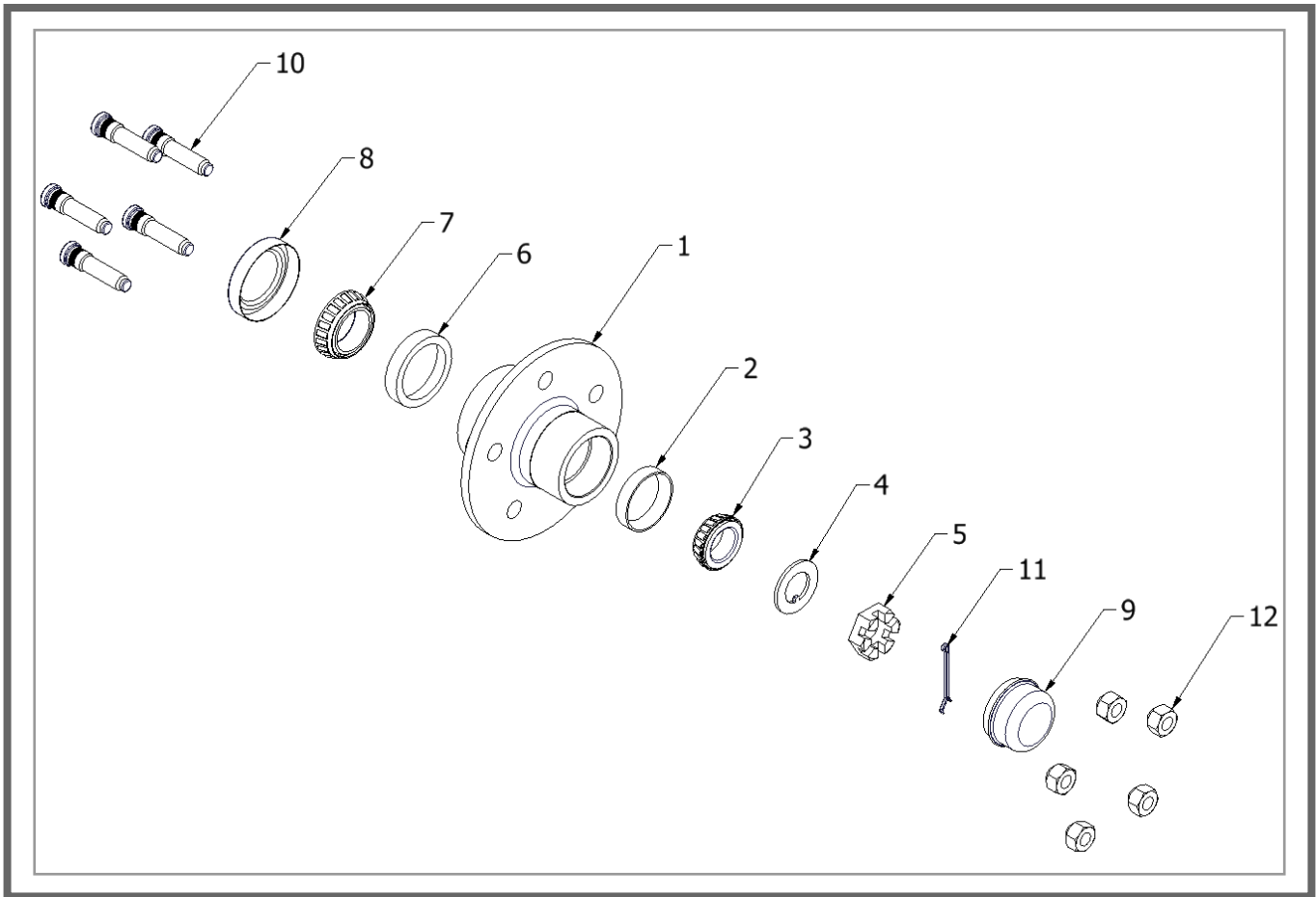

Drawing 6.0

Front Hub Assembly

ITEM	QTY	P.N.	DESCRIPTION
1	1	04-1017	Hub, Front Axle
2	1	04-1016	Cup, Outer Bearing
3	1	04-1014	Cone, Outer Bearing
4	1	02-12055	Washer
5	1	02-1205	Nut, Castle
6	1	04-1015	Cup, Inner Bearing
7	1	04-1013	Cone, Inner bearing
8	1	04-1012	Seal bearing
9	1	04-1019	Cap, Hub
10	5	02-1017	Stud
11	1	02-1303	Pin, Cotter
12	5	02-3065	Nut, lug, 1/2"

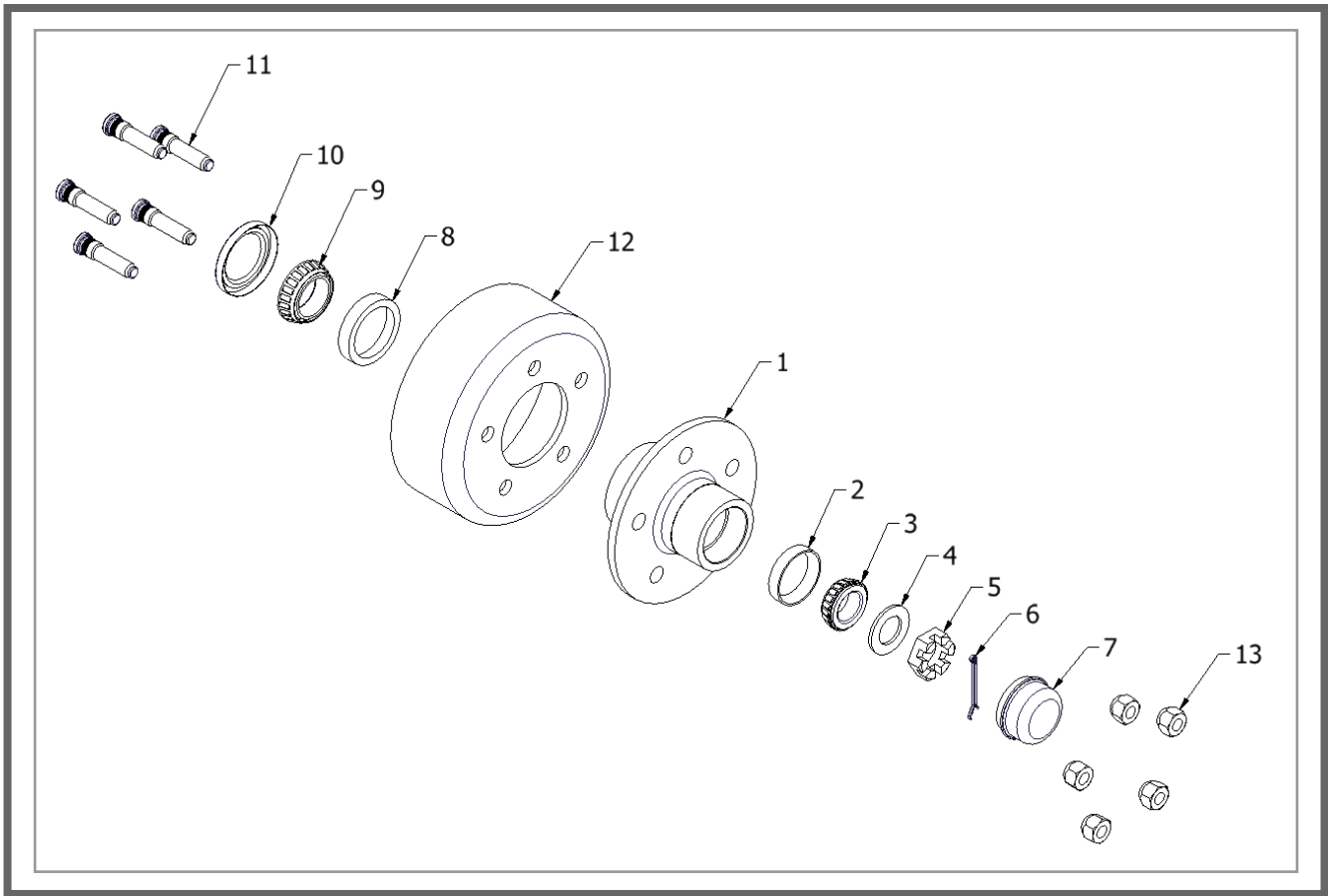

Drawing 7.0

Rear Hub and Drum Assembly

ITEM	QTY	P.N.	DESCRIPTION
1	1	04-1017	Hub, Rear Axle
2	1	04-1016	Cup, Outer Bearing
3	1	04-1014	Cone, Outer Bearing
4	2	02-12055	Washer
5	1	02-1205	Nut, Castle
6	1	02-1303	Pin, Cotter
7	2	04-1019	Cap, Hub
8	2	04-1015	Cup, Inner Bearing
9	1	04-1013	Cone, Inner bearing
10	1	04-1012	Seal, Bearing
11	5	02-1303	Stud
12	1	08-10111	Drum, Brake
13	5	02-3065	Nut Lug

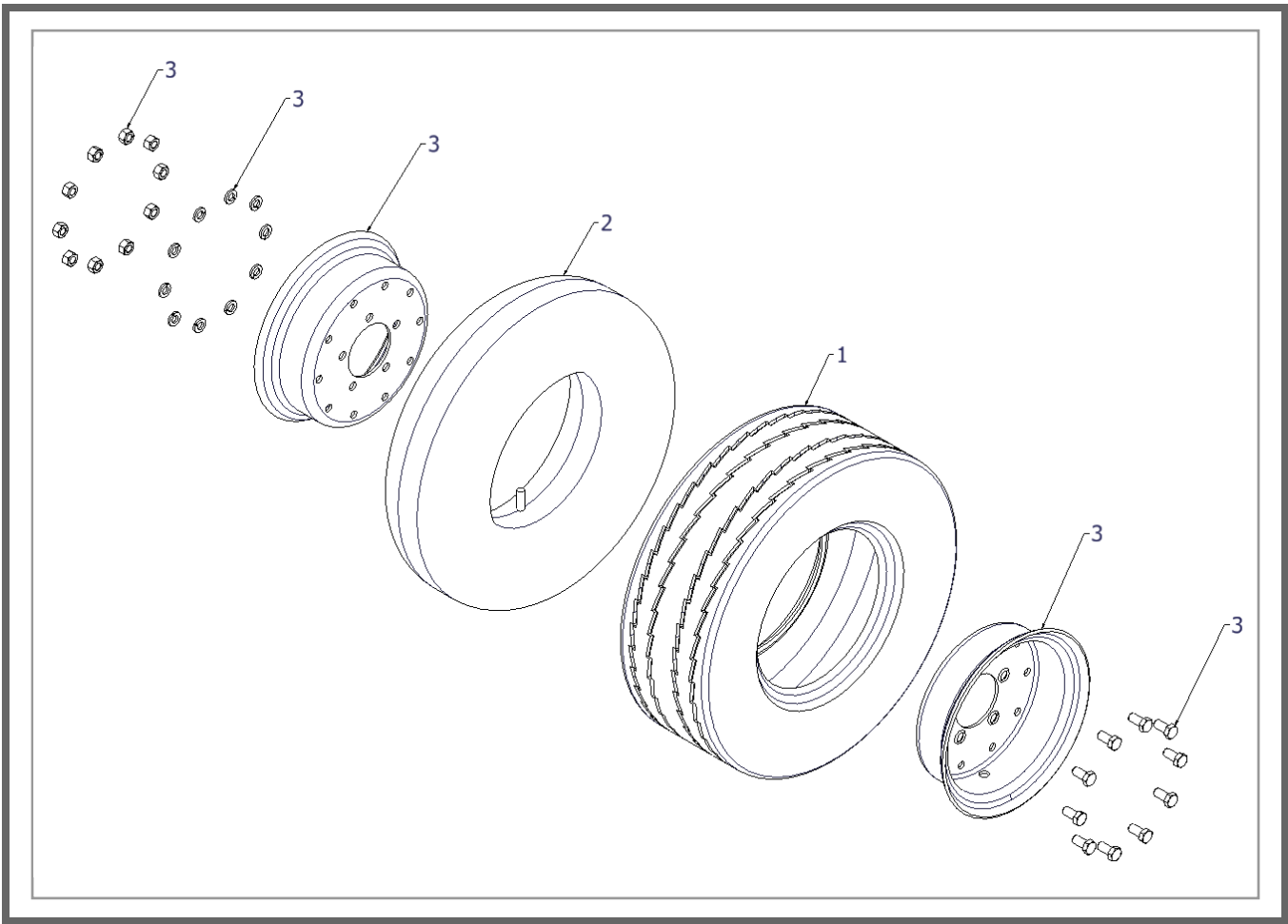

Drawing 8.0

Wheel and Tire Assembly

ITEM	QTY	P.N.	DESCRIPTION
	4	07-10201-1	Complete Wheel Assembly (All Numbers)
1	1	04-10221	Tire, 20.5x 8.0-10, E-Range
2	1	04-1059	Inner Tube
3	1	04-1020	Split Rim Wheel Assembly