



CONFIDENTIAL PROPRIETARY INFORMATION

Reproductions of this data or the manufacturing of products from this data by anyone other than Spokane Stainless Technologies, Inc[™] of Spokane Valley Washington is strictly prohibited without written consent. The Spokane Stainless Technologies logo is a registered trademark of Spokane Stainless Technologies, Inc..

TECHNICAL MANUAL

NV SERIES

(Non-Vacuum Unit)

200/ 400/ 600 Gallon Capacity

(757, 1514, 2271 Liters)

Spokane Stainless Technologies, Inc[™]

SPOKANE STAINLESS TECHNOLOGIES, INC.

This document discloses subject matter in which Spokane Stainless Technologies, Inc. has Proprietary rights and such subject matter shall not, without the written permission of Spokane Stainless Technologies, Inc., be either (A) used, released or disclosed in whole or in part outside the government,(B) used in whole or in part by the government, for manufacture, or (C) used by a party other than the government, except for (1) emergency repair or overhaul work only, by or for the government, where the item or process concerned is not otherwise reasonably available to enable timely performance of the work, provided that release of disclosure hereof outside the government shall be made subject to a prohibition against further use, release of disclosure, or (2) release to a foreign government, or for emergency repair or overhaul work by or for such government under the conditions of (1) above. This legend shall be marked on any reproduction hereof in whole or in part.

©COPYRIGHT 2022 By SPOKANE STAINLESS TECHNOLOGIES INC.

MNUL-004

REVISION E

SEPTEMBER 2022

Section

1.0	Introduction.....	Page 2
1.1	Specifications 200 Gallon.....	Page 3
1.1	Specifications 400 Gallon.....	Page 4
1.1	Specifications 600 Gallon.....	Page 5
1.2	Component Identification.....	Page 6
2.0	Safety Guidelines.....	Page 7
2.1	General Safety.....	Page 7
2.2	Protective Clothing.....	Page 7
2.3	Static Bonding and Grounding And Other Fire Hazard Precautions.....	Page 7
2.4	Lockout / Tagout.....	Page 7
2.5	Recoverable Products.....	Page 7
3.0	Operation Instructions.....	Page 8
3.1	Using the Non-Vacuum Unit When Draining Fuel.....	Page 8
3.2	Using the Telescopic Funnel.....	Page 8
4.0	Maintenance and Assembly.....	Page 9
4.1	Repair and Replace Instructions.....	Page 9
4.2	Manway Assembly and Maintenance.....	Page 9
4.3	Telescoping Funnel Assembly.....	Page 10
4.4	Front Undercarriage Assembly.....	Page 11
4.5	Front Wheel Assembly Removal.....	Page 11
4.6	Front Hub Assembly.....	Page 11
4.7	Tow Latch Assembly.....	Page 12
4.8	Spindle Assembly.....	Page 13
4.9	Steering Arm Assembly.....	Page 13
4.10	Tie Rod Assembly.....	Page 13
4.11	Front Undercarriage Assembly Removal.....	Page 14
4.12	Rear Undercarriage Assembly.....	Page 14
4.13	Rear Wheel Assembly Removal.....	Page 14
4.14	Rear Hub/Brake Drum Assembly.....	Page 15
4.15	Mechanical Brake Assembly.....	Page 15
4.16	Parking Brake Assembly and Adjustment....	Page 16
4.17	Brake Handle and Cable Assembly.....	Page 16
4.18	Rear Undercarriage Assembly Removal.....	Page 17
4.19	Wheel Assembly.....	Page 17
5.0	Parts Breakdown.....	Page 18

Drawing No.

1.0	NV Overview, Component Identification.....	Page 19
2.0	Manway Assembly.....	Page 20
3.0	Telescoping Funnel Assembly.....	Page 21
4.0	Front Undercarriage Assembly.....	Page 22
5.0	Rear Undercarriage and Axle Assembly.....	Page 23
6.0	Front Hub Assembly.....	Page 24
7.0	Rear Hub & Drum Assembly.....	Page 25
8.0	Wheel & Tire Assembly.....	Page 26

SECTION 1.0

INTRODUCTION

IMPORTANT:

YOU MUST READ THIS MANUAL IN ITS ENTIRETY BEFORE OPERATING, SHIPPING OR PERFORMING MAINTENANCE PROCEDURES. FLAMMABLE AND COMBUSTIBLE VAPORS CAN CAUSE FIRE, AND/OR EXPLOSION AND CAN LEAD TO SERIOUS INJURY OR DEATH.

The instructions in this manual cover the operation and maintenance of the Non-Vacuum Unit: 200, 400, and 600 Gallon Model Numbers NV 200S, NV 400S, NV 600S, NV 216S, NV 416S, and NV 616S, parts are manufactured by Spokane Stainless Technologies, Inc. of Spokane Valley, Washington.

The 200, 400 and 600 gallon non-vacuum units are referred to as NV throughout the publication. The NV provides a convenient, safe and efficient means to remove and store aviation fuels. The non-vacuum unit is a product of Spokane Stainless Technologies, Inc.

This manual describes the NV, the safety guidelines that must be followed while operating the NV, Maintenance and Assembly instructions and a parts breakdown section that provides part numbers and all of the necessary information to order parts, as well as allow for identification of all components on the NV.

DESCRIPTION

Refer to the chart on the next page for location and identification of major components and particulars of each size. The non-vacuum unit consists of a single shell used for primary containment. These tank depositories consist of a front and rear undercarriage, flip-lock manway and a fuel level indicator. All NV's have the option of being equipped with a telescoping funnel.

1.1

Specifications for the Non Vacuum Unit 200 Gallon

Tank Volume:	
Nominal Capacity	200-gallons
Max Capacity	220-gallons
Equipment Dimensions:	
Length (Tow bar down)	153-inches
(Tow bar up)	93-inches
Width (Tire to tire).....	59-inches
Height (Tow bar down)	60-inches
(Tow bar up)	72-inches
Weight (Empty)	1,400-pounds
(Full, at nominal capacity with fuel)	2,920-pounds
*Telescoping Funnel Height (Fully collapsed)	42-inches
(Fully extended)	234-inches
Ground Clearance (At tow bar)	6-inches
(At axle).....	8-inches
Environmental Conditions:	
Operating Temperature Range	-25°F to 110°F
Storage Temperature Range	-40°F to 150°F
Operational Characteristics:	
Tank Vacuum Pressure	8-inches Hg
Tank Vacuum Flow	89-SCFM
Towing Characteristics:	
Speed, Forward Direction	15-MPH
Speed, Backward Direction	(hand push/pull only)
Turning Radius (Curb to curb)	372-inches
Wheels and Tires:	
Tire Size	20.5 x 8.0-10
E Range Tire Pressure (Cold) (See Sidewall)	90-PSIG
Lug Nut Torque	100ft.-lbs.
Split Rim Nut Torque	75 ft.-lbs.
Other Characteristics:	
Double Wall Construction.....	(optional)

* The Telescoping Funnel is an optional feature that can be purchased with the 200-gallon NV

1.1

Specifications for the Non Vacuum Unit 400 Gallon

Tank Volume:	
Nominal Capacity	400-gallons
Max Capacity	440-gallons
Equipment Dimensions:	
Length (Tow bar down)	187-inches
(Tow bar up)	128-inches
Width (Tire to tire).....	76-inches
Height (Tow bar down)	60-inches
(Tow bar up)	72-inches
Weight (Empty)	1,650-pounds
(Full, at nominal capacity with fuel)	4,690-pounds
*Telescoping Funnel Height (Fully collapsed)	42-inches
(Fully extended)	234-inches
Ground Clearance (At tow bar)	6-inches
(At axle).....	8-inches
Environmental Conditions:	
Operating Temperature Range	-25°F to 110°F
Storage Temperature Range	-40°F to 150°F
Operational Characteristics:	
Tank Vacuum Pressure	8-inches Hg
Tank Vacuum Flow	89-SCFM
Towing Characteristics:	
Speed, Forward Direction	15-MPH
Speed, Backward Direction	(hand push/pull only)
Turning Radius (Curb to curb)	372-inches
Wheels and Tires:	
Tire Size	20.5 x 8.0-10
E Range Tire Pressure (Cold) (See Sidewall)	90-PSIG
Lug Nut Torque	100ft.-lbs.
Split Rim Nut Torque	75 ft.-lbs.
Other Characteristics:	
Double Wall Construction.....	(optional)

* The Telescoping Funnel is an optional feature that can be purchased with the 200-gallon NV

1.1

Specifications for the Non Vacuum Unit 600 Gallon

Tank Volume:	
Nominal Capacity	600-gallons
Max Capacity	660-gallons
Equipment Dimensions:	
Length (Tow bar down)	187-inches
(Tow bar up)	128-inches
Width (Tire to tire).....	76-inches
Height (Tow bar down)	62-inches
(Tow bar up)	72-inches
Weight (Empty)	2,135-pounds
(Full, at nominal capacity with fuel)	6,695-pounds
*Telescoping Funnel Height (Fully collapsed)	62-inches
(Fully extended)	254-inches
Ground Clearance (At tow bar)	6-inches
(At axle).....	8-inches
Environmental Conditions:	
Operating Temperature Range	-25°F to 110°F
Storage Temperature Range	-40°F to 150°F
Operational Characteristics:	
Tank Vacuum Pressure	8-inches Hg
Tank Vacuum Flow	89-SCFM
Towing Characteristics:	
Speed, Forward Direction	15-MPH
Speed, Backward Direction	(hand push/pull only)
Turning Radius (Curb to curb)	372-inches
Wheels and Tires:	
Tire Size	20.5 x 8.0-10
E Range Tire Pressure (Cold) (See Sidewall)	90-PSIG
Lug Nut Torque	100ft.-lbs.
Split Rim Nut Torque	75 ft.-lbs.
Other Characteristics:	
Double Wall Construction.....	(optional)

* The Telescoping Funnel is an optional feature that can be purchased with the 200-gallon NV

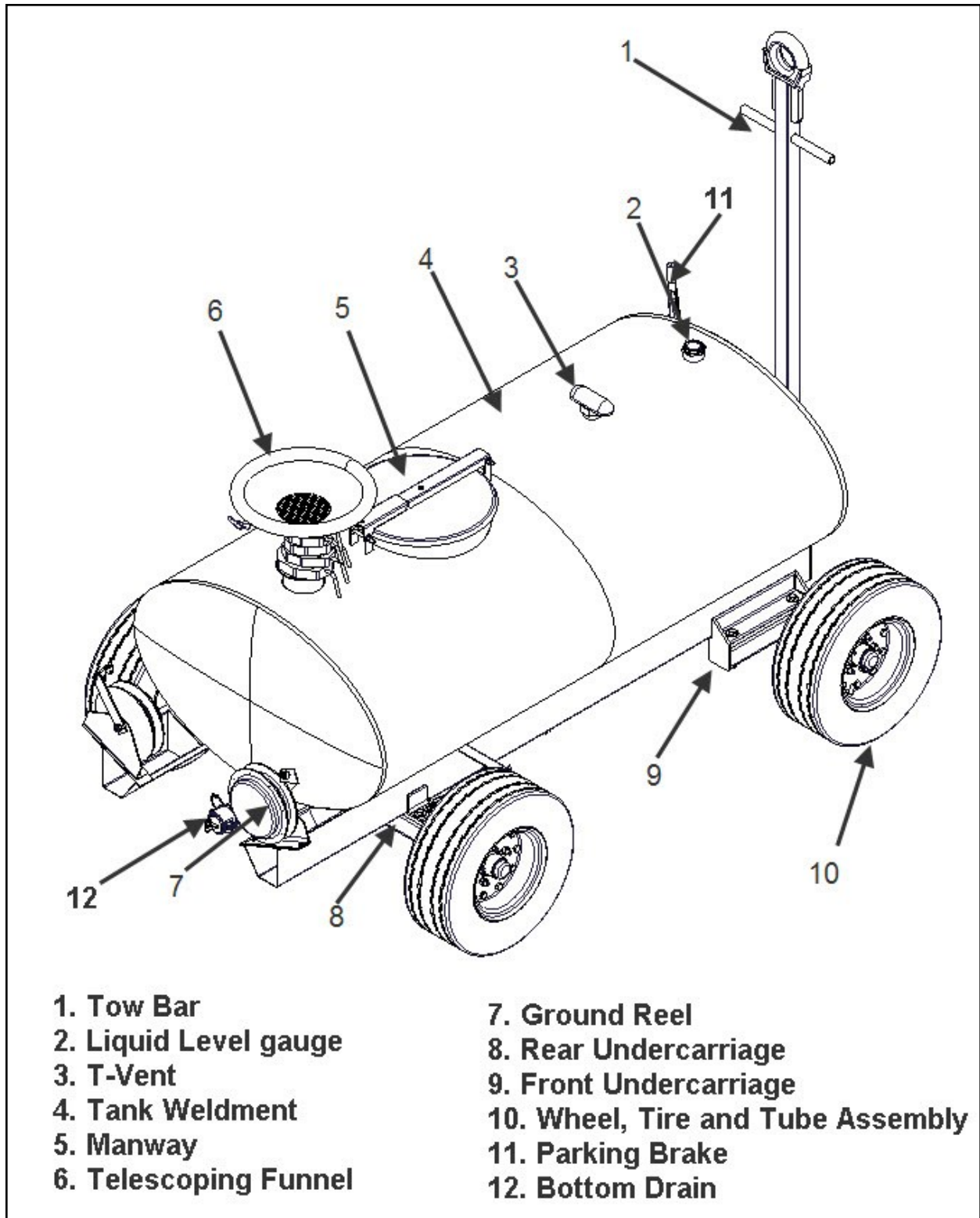

1.2

Figure 1-1 Component Identification

SECTION 2.0

SAFETY GUIDELINES

Within this manual are guidelines and safety recommendations for use of the NV. It is the responsibility of the end user to completely read this manual and comply with all local, state and federal laws and **regulations applicable for fueling and defueling aircraft**. Spokane Industries Inc. is not responsible for industry specific information on safety management, employment safety, health standards, safety codes, etc. Contact your local safety manager or industrial safety representative. It is the responsibility of the end user to ensure persons operating this equipment:

- **Are trained, authorized and permitted to use the equipment.**
- **Have physical and the mental ability to operate this equipment safely.**
- **Are aware of the potential hazards associated with this equipment, i.e static electricity, electrical shock, fuel spills and pinch points.**

2.1 General Safety Instructions

This manual describes physical and chemical processes which may cause injury or death to personnel, or damage to equipment if not properly followed. This safety summary includes general safety precautions that must be understood and applied during operation and maintenance to ensure safety and protection of equipment.

2.2 Protective Clothing

When fuels are being handled, approved equipment such as gloves, eye protection, face shields, etc. shall be used.

2.3 Static Bonding and Grounding and Other Fire Hazard Precautions

Improper static bonding and grounding can lead to a fire, and as with any other equipment dealing with fuel, there is always a risk of fire if all safety precautions are not followed or the equipment is not used correctly. Make sure to read and understand all instructions before operating this equipment.

2.4 Lockout / Tagout

Personnel shall be aware of the hazards associated with unguarded machinery parts, capacitors, gaseous and wet pipe systems, spring loaded devices, etc. Lockout / Tagout the energy source prior to performing maintenance, adjustment or other procedures that would bypass safety guards, barriers, or otherwise expose personnel to hazardous energy sources. Any equipment, machine or process that could unexpectedly energize, start-up or release energy will be equipped with a means to lockout / tagout the energy sources.

2.5 Recoverable Products

This equipment has been designed to operate outdoors only. Flammable and/or combustible vapors in ignitable quantities could be produced under certain circumstances. Additionally, local protocols must be consulted to determine if fuel draining equipment can be used in the location being considered.

SECTION 3.0

OPERATION INSTRUCTIONS

3.1 Using the Non-Vacuum Unit When Draining Fuel

- a. Position the unit near the item to be drained.
- b. Ground unit to appropriate grounding sites.
- c. Open Manway cover to gain access to NV tank.
- d. Perform defuel operations as needed, monitor tank fluid level to prevent over fill conditions.
- e. When finished, close the Manway cover securely.
- f. Remember to disconnect the ground cables if the NV unit is to be towed.
- g. Tow and position NV unit over approved waste receptacle, or connect drain hose, if available, to drain valve cam lock.
- h. Open drain valve slowly.

3.2 Using the telescoping Funnel (This piece is optional)

The telescoping funnel is designed as a gravity feed system, no additional support equipment is needed.

CAUTION

Make sure the unit has enough storage capacity for the defueling operation.

- a. Position telescoping funnel under the drain.
- b. Ground the unit to approved grounding sites.

- c. Open cover on top of funnel, clean screen if necessary.
- d. Extend the funnel by raising the upper section first, tightening clamp securely. Extend the next section, if needed, and tighten clamp securely.
- e. Begin the defueling process.
- f. When finished, close the funnel isolation valve.
- g. Lower funnel sections in reverse order.
- h. Close and latch the funnel cover.

WARNING

Raising telescoping funnel sections creates a pinch hazard for hands. Make sure that you have a tight grip on the sections during the lifting process and that the clamps are securely tightened before extending each section.

SECTION 4.0

MAINTENANCE AND ASSEMBLY

The NV should always be inspected prior to use to make sure it is in working order.

4.1 Repair and Replace Instructions

Remember to set the parking brake while performing maintenance procedures. Approved jack stands and wheel chocks must also be used. Serious injury or death may occur from rolling or falling equipment.

The following procedures are used for the disassembly and reassembly for equipment components.

4.2 Manway Assembly and Maintenance

The manway assembly is located on the top of the tank. The manway assembly has one adjustment point. Use Figure 4-1 for the following maintenance steps.

Manway Disassembly/Reassembly

- a. Open handle (2).
- b. Open Manway Assembly.
- c. Remove nut (7).
- d. Remove gasket retainer (5), gasket (4), and lid (3).
- e. Remove bolt (6) and nut (10) to remove cross-arm (1).
- f. Repair / replace components
- g. Reassemble in reverse order, leaving nut (7) only partially threaded onto cross arm (1).

Manway Adjustment

- a. Open handle (2).
- b. Open Manway Assembly.
- c. Rotate nut (11) to adjust lid position. Turn clockwise to move lid closer to the tank. Turn counter clockwise to move the lid away from the tank.
- d. Tighten nut (7) until snug.

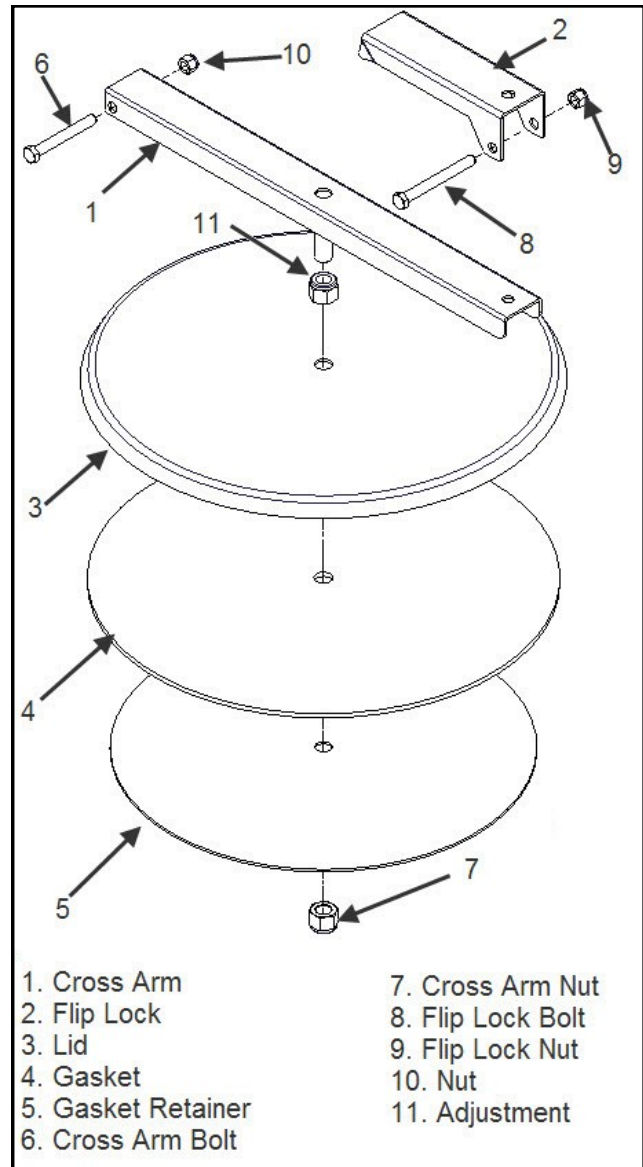

Figure 4-1 Manway Assembly

4.3 Telescoping Funnel Assembly

The instructions for assembly and maintenance for the optional Telescoping funnel can be found on this page. Please refer to Figure 4-2 for all numerical references regarding the telescoping assembly with the exception of the base clamp which is referenced in Figure 4-3.

The Telescoping Funnel Assembly is located at the top, rear of the tank. The assembly consists of (starting at the top), a cover assembly, a gasket, a funnel screen, a funnel section and four telescoping sections and a base clamp.

Funnel Cover Assembly

The funnel cover (1) is removed by removing nut (6) and bolt (5).

Funnel Gasket

The funnel gasket (3) is replaced by opening funnel cover (1). Remove damaged gasket and install new one.

Funnel Screen

The funnel screen (2), prevents FOD from entering the tank. The screen is replaced by opening the funnel cover and removing nut (7). Replace screen and reinstall nut.

Funnel and Telescoping Sections

The funnel section (4) and telescoping sections are removed independently; starting at the uppermost subassembly, until the section needing repair/replacement is reached.

Base Clamp

The base clamp (4), is attached directly to the tank.

- Rotate entire funnel assembly (all telescoping section and funnel section) 180 degrees until clamp handles are facing the front of the tank (toward the tow bar).
- Lift entire funnel assembly by the largest telescoping section. When bottom edge of bottom telescoping section tube reaches the base clamp (4), lift firmly and rotate assembly slightly clockwise and counterclockwise to guide alignment past alignment notch in base clamp (see reference arrow A).
- Remove bolts (5) and lock washers (6).
- Repair / replace components.

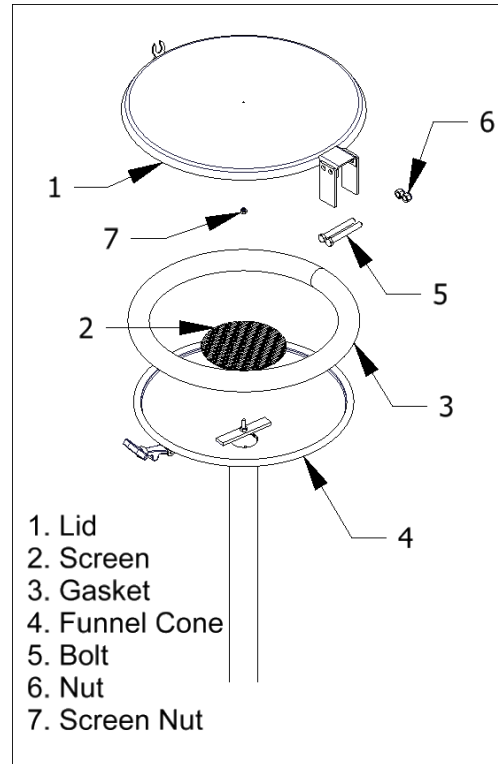

Figure 4-2 Funnel Section Assembly

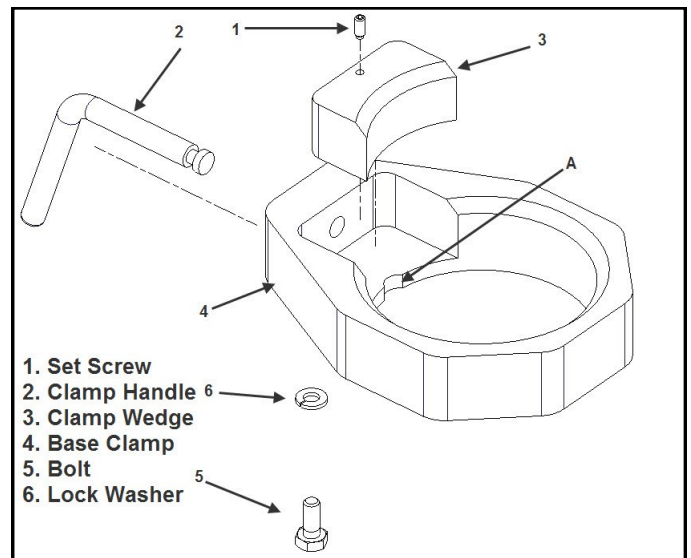

Figure 4-3 Base Clamp

4.4 Front Undercarriage Assembly

The Front Undercarriage assembly consists of a wheel assembly, a hub assembly, a spindle assembly, a tow latch assembly, a steering arm assembly and an adjustable tie rod assembly.

4.5 Front Wheel Assembly Removal

To remove the wheel assembly, the equipment must have the front end raised and placed on approved jack stands.

- Loosen lug nuts on wheel assembly requiring maintenance one turn while equipment is still on the ground.
- Raise equipment with suitable maintenance jack (see Figure 4-4, reference arrow A for jack placement) high enough to remove wheel assembly.
- Place approved jack stands under front axle (see Figure 4-4, reference arrow for stand placement).
- Remove lug nuts of wheel assembly needing maintenance, and remove.

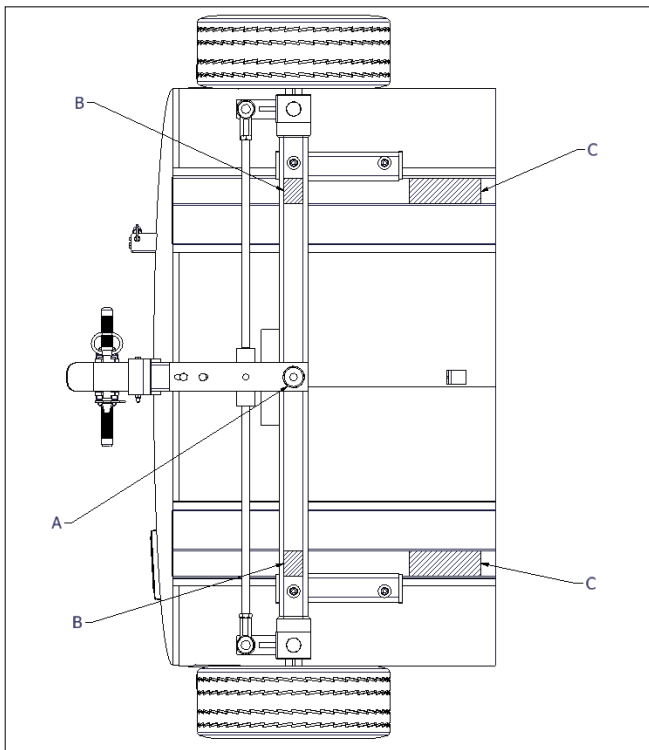

Figure 4-4 Lift Points

4.6 Front Hub Assembly

To remove the front hub assembly, follow these maintenance steps using Figure 4-5.

- Remove dust cap (1) by lightly tapping with a rubber hammer.
- Remove cotter pin (2), castle nut (3), and washer (4).
- Grasp front hub (7) and pull firmly. Ensure that bearing (5) doesn't separate from hub and strike the ground.
- Remove bearing (5), seal (10), and bearing (9) from the front hub (7). Using a suitable H-frame press, remove bearing races (6) and (8).
- Replace components and grease bearings before reassembly.
- When reassembling, the Castle nut (3) should be tightened until the hub assembly rotates past free.

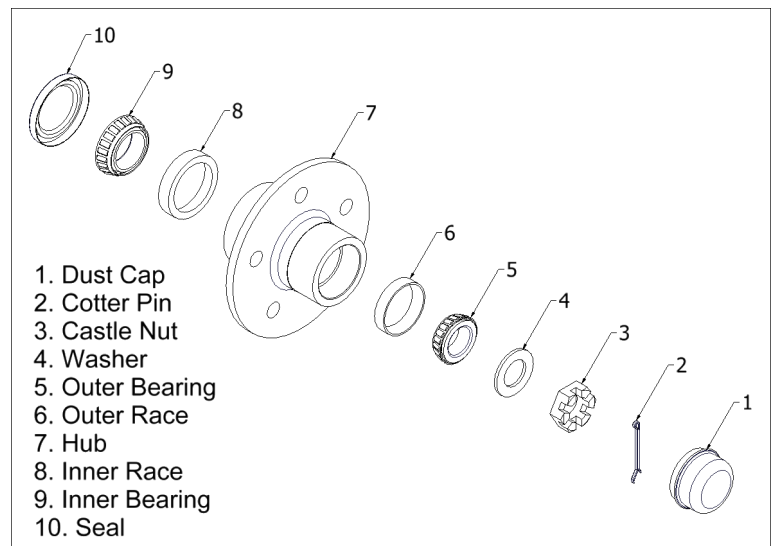

Figure 4-5 Front Hub Assembly

4.7 Tow Latch Assembly

The tow latch assembly is used to secure the tow bar in the upright position. (See Figure 4-6).

- a. Remove tow bar (1) by placing the tow bar in upright, latched position. Remove pin (2). While holding onto tow bar, place foot on toe latch assembly (See reference arrow A) and depress.
- b. Pull hitch pin (3) from steering arm assembly and place tow bar to the side.

The remaining steps are illustrated in Figure 4-7.

- c. Remove bolt (7) and nut (10).
- d. Rotate toe latch plate (9) downward to free from assembly.
- e. Detach spring (8) from toe latch plate (9) and spring anchor (24).

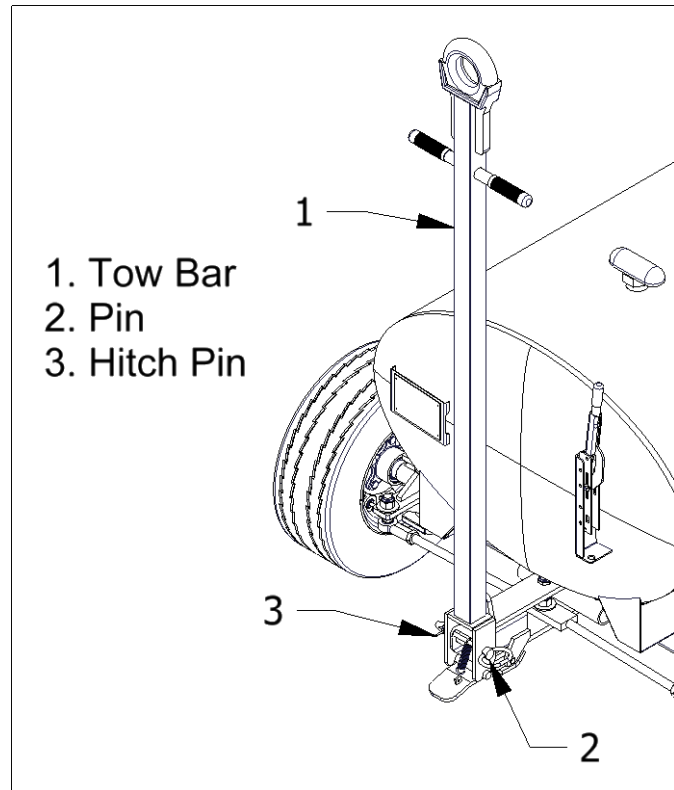

Figure 4-6 Tow Bar Removal

NOTE:

Removing hitch pin from steering arm assembly will free tow bar. Prevent tow bar from falling by holding it firmly until free. Set aside.

4.8 Spindle Assembly

To remove the spindle assembly, follow the maintenance steps for the front hub assembly before beginning the next steps. See Figure 4-7.

- Remove nut (17) and washer (16).
- Remove nut (21) and washer (20).
- Remove king pin (14) from yoke by using a rubber hammer.
- Grasp spindle assembly (18) and rotate toward front of tank until the yoke is free.
- Remove spindle assembly from tie rod (15).
- Remove bushings (19) with bronze punch and hammer.
- Repair / replace components.

4.9 Steering Arm Assembly

- Remove the thin lock nut (1).
- Remove nuts (17) and flat washers (16).
- Remove bolts (22) and nuts (5). Allow lower steering arm subassembly (11), bushing (3), and tie rod assembly

- (12) to drop down; place to side.
- Lift upper steering arm subassembly vertically to clear pivot pin (reference arrow (A)), then pull to clear tank and front axle tube.
- Remove tie rod assembly (12) by removing nut (6) and flat washer (4). Note the presence of the bushings (23).
- Repair / replace components.

4.10 Tie Rod Assembly

Refer to Figure 4-7 for the removal of the tie rod. Before beginning this process make sure that you have followed the steps for the steering arm assembly. **Note presence and location of bushings (23) when removing tie rod assembly from steering arm assembly.**

- Disassemble the tie rod assembly by the unthreaded components. Before disassembly mark rod length with masking tape. Note that tie rod ends angle downward when reassembling.
- Adjust tire toe in /toe out as needed.

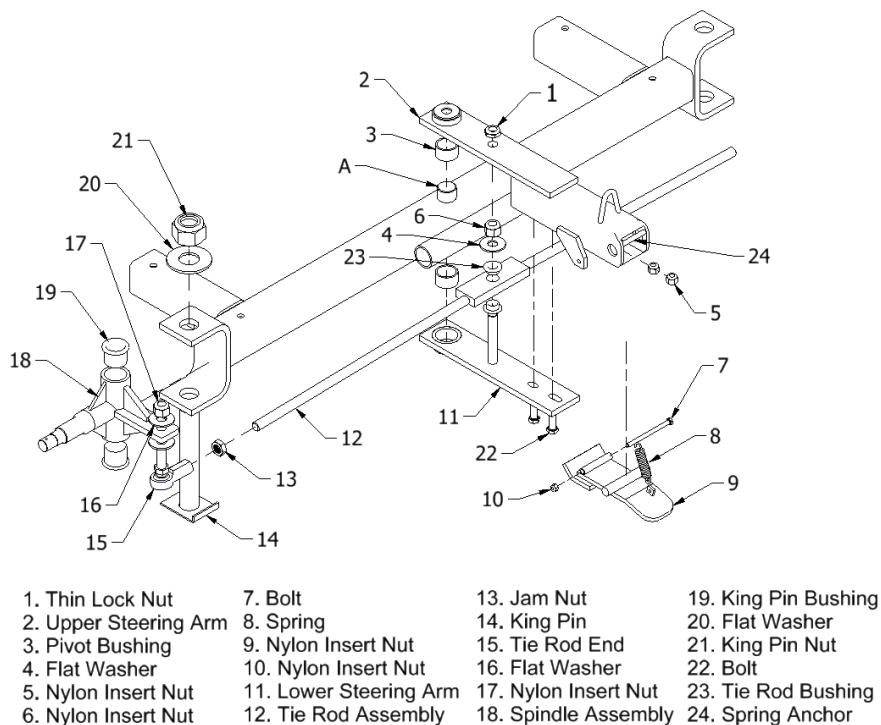

Figure 4-7 Exploded View of Undercarriage

4.11 Front Undercarriage Removal

To remove the entire Front Undercarriage assembly, the equipment must have the front end raised. See Figure 4-4 for lift points.

- Raise equipment with suitable maintenance jack (see Figure 4-4 arrow A for jack placement) to allow four inches of space between the wheels and ground.
- Place cribbing under tank skirts (see Figure 4-4, reference arrows C) to safely support the equipment.
- Lower onto cribbing. Leave jack in place.
- Raise jack to apply slight pressure on assembly. **(Tow bar must be in upright position.)**
- Remove bolts (2) and nuts (3).
- Carefully lower jack and assembly until wheels are on the ground and front axle tube clears tank mounts.
- Pull Front Undercarriage forward. Note location of rubber mounting pads (5).

▲WARNING

Use suitable lifting and support equipment when performing these steps. Serious injury or death could occur from rolling or falling equipment.

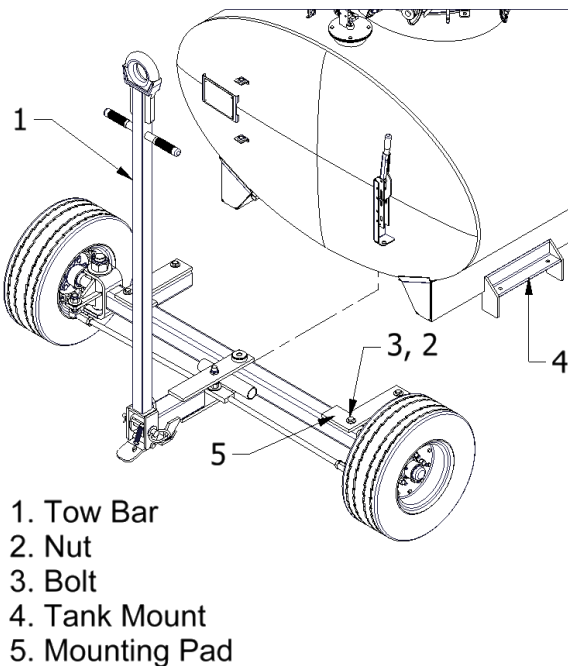

- Tow Bar
- Nut
- Bolt
- Tank Mount
- Mounting Pad

Figure 4-8 Front Undercarriage Removal

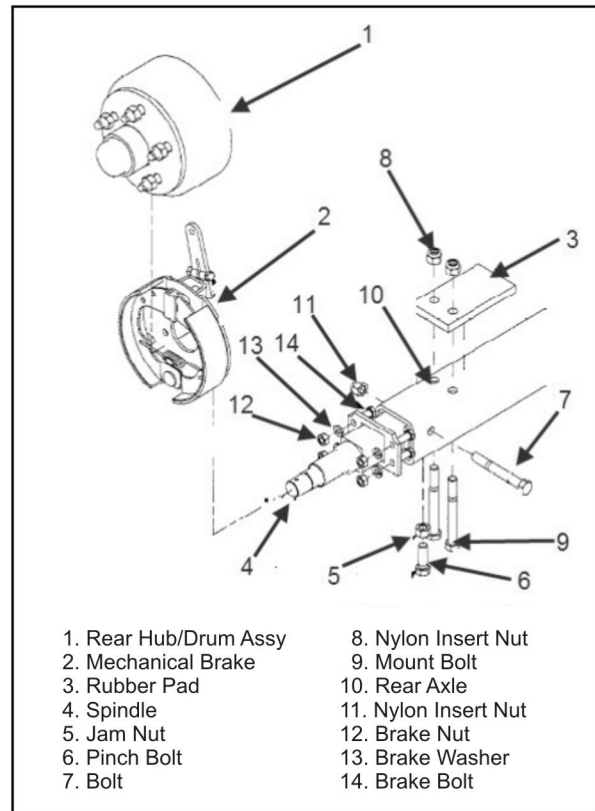

- | | |
|-----------------------|----------------------|
| 1. Rear Hub/Drum Assy | 8. Nylon Insert Nut |
| 2. Mechanical Brake | 9. Mount Bolt |
| 3. Rubber Pad | 10. Rear Axle |
| 4. Spindle | 11. Nylon Insert Nut |
| 5. Jam Nut | 12. Brake Nut |
| 6. Pinch Bolt | 13. Brake Washer |
| 7. Bolt | 14. Brake Bolt |

Figure 4-9 Rear Undercarriage Removal

4.12 Rear Undercarriage Assembly

See Figure 4-9 for the following maintenance steps. The rear undercarriage assembly consists of: a wheel assembly, a hub and brake drum assembly (1), a mechanical parking brake assembly (2), a rear spindle (4), and the axle (10).

4.13 Rear Wheel Assembly Removal

To remove wheel assembly, the equipment must have the back end raised and placed on approved jack stands. Points A and B are similar on both the rear and front axles.

- Raise equipment with suitable maintenance jack high enough to remove wheel assembly. (see Figure 4-4, arrow A for jack placement).
- Place approved jack stands under rear axle (see Figure 4-4, arrow B for stand placement).
- Remove lug nuts of wheel assembly needing maintenance.

4.14 Rear Hub / Brake Drum Assembly

To remove the rear hub and brake drum assembly, follow the maintenance steps for the rear wheel assembly removal before beginning the next steps. Figure 4-10 illustrates the process for the rear hub/ brake drum assembly.

- Remove dust cap (1) by lightly tapping with a rubber hammer.
- Remove cotter pin (2), castle nut (3) and washer (4).
- Grasp rear hub (7) and drum (8) and pull outward firmly. Ensure that bearing (5) doesn't fall from hub and strike the ground.
- Remove bearing (5), seal (11), and bearing (10) from the rear hub (7).
- Using a suitable H-frame press, remove bearing races (6) and (9).
- Remove drum (8) by pressing out wheel studs (12) in suitable H-frame press.
- Replace components and grease bearings before reassembly.
- Reassemble in reverse order. Castle nut (3) should be tightened until the hub assembly rotates barely past free.

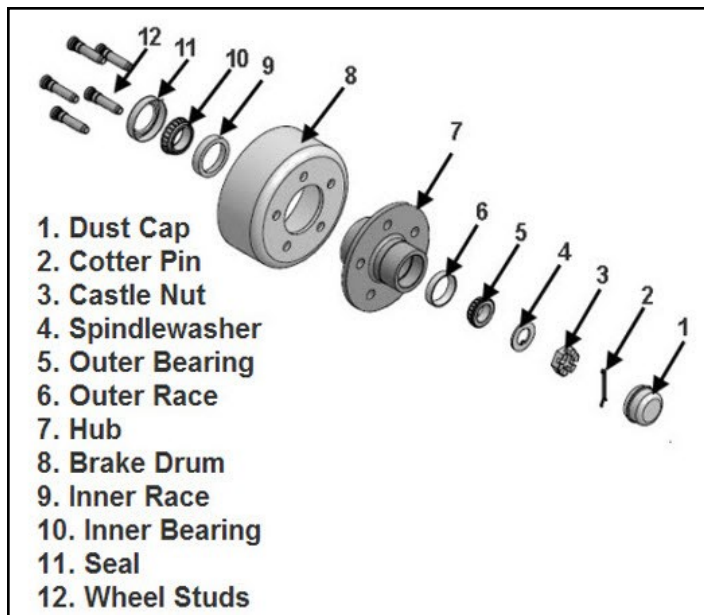

Figure 4-10 Rear Hub and Brake Drum

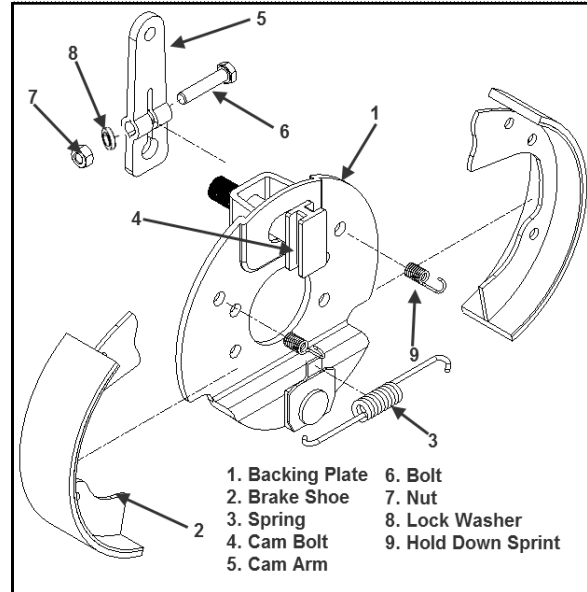

Figure 4-11 Mechanical Brake

4.15 Mechanical Brake Assembly

The assembly can be disassembled while attached to the rear spindle or removed from the unit. See Figure 4-11 unless otherwise specified.

- Remove Rear Wheel Assembly as described in section 4.13.
- Remove Rear Hub and Brake Drum Assembly as described in section 4.14 on this page.
- Remove brake cable end from arm (5) as described in Section 4.17, step (a).
- Remove nuts (12), washers (13), and bolts (14) shown in Figure 4-9.
- Remove Mechanical Brake Assembly and place on flat surface.
- Remove spring (3).
- Release brake shoes (2) by removing springs (9) from the backing plate (1).
- Remove nut (7), lock washer (8), and bolt (6) to release arm (5).
- Remove brake cam (4) by pulling directly outward.

NOTE: Steps (d) and (e) are needed only if Mechanical Brake Assembly is to be removed from the axle.

4.16 Parking Brake Assembly and Adjustment

The parking brake assembly consists of a brake handle, cable assembly and a mechanical brake assembly. The parking brake can be adjusted at three different locations.

An in-field adjustment can be made at the brake handle by turning the handle cap clockwise to tighten brakes and counterclockwise to loosen the brakes (see reference arrow D in Figure 4-12.) This adjustment must be made with the brake handle in the off position. Maintenance level adjustments can be made at reference arrow E and reference arrow F of Figure 4-12 (each side).

4.17 Brake Handle and Cable Assembly

The brake handle and cable assembly only need to be disassembled to the point that the repair is needed. These instructions start at the wheel assembly and progress toward the brake handle.

- a. Remove cotter pin (13) and clevis pin (14) to release clevis (12).
- b. Unthread clevis (12) from cable
- c. Remove nut (15) and remove cable housing (10) from bracket.
- d. Remove nut at opposite end of cable and disassemble cable linkage parts (6), (7), (8), and (9).
- e. Repeat steps a. through d. for opposite side.
- f. Remove nut (4) to release cable equalizer (5).
- g. Repeat step c. for cable housing leading to brake handle.
- h. Remove nut at other end of cable and release cable by disassembling cable linkage from brake handle (1).
- i. Remove bolts (2) and nuts (3) to free brake handle (1).

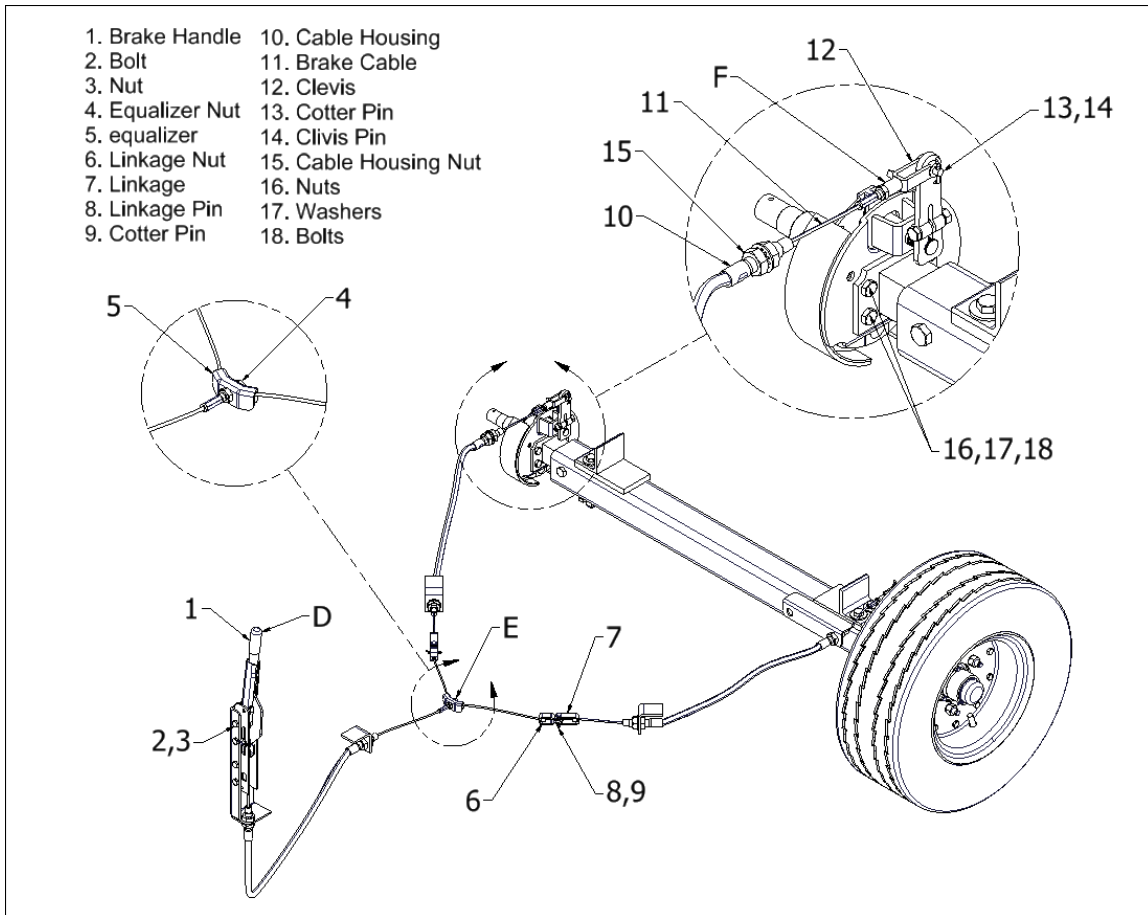

Figure 4-12 Brake and Cable Assembly

4.18 Rear Undercarriage Assembly Removal

To remove the entire Rear Undercarriage assembly, the equipment must have the back end raised. See Section 4.12 and use figure 4-13 for these instructions.

- a. Raise equipment with suitable maintenance jack (see Figure 4-13 reference arrow A for jack placement) and allow for 2-inches of space between the wheels and the ground.
- b. Place cribbing under tank skids to safely support the equipment. (see Figure 4-13, reference points labeled with a C).
- c. Lower onto cribbing. Leave jack in place.
- d. Disconnect parking brake cables at mechanical brake assembly as described in Section 4.17, step (a).
- e. Raise jack to apply slight pressure on assembly.
- f. Remove mounting nuts and bolts from both sides of axle assembly.
- g. Carefully lower jack and assembly until wheels are on the ground and the front axle tube clears tank mounts.

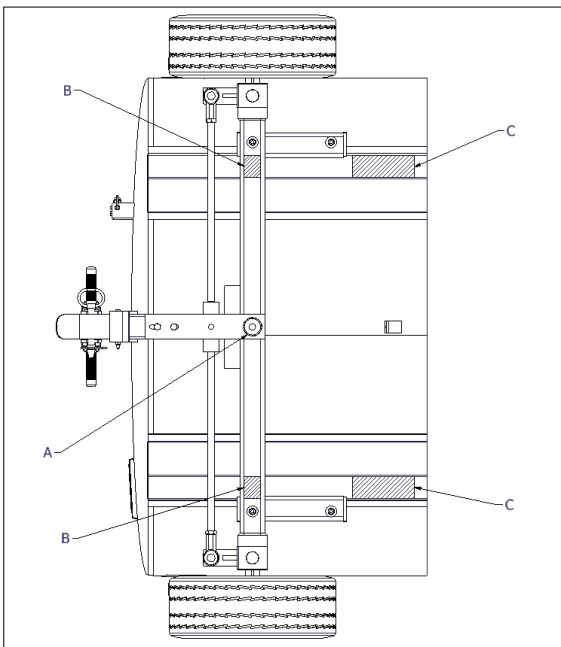

Figure 4-13 Lift Points

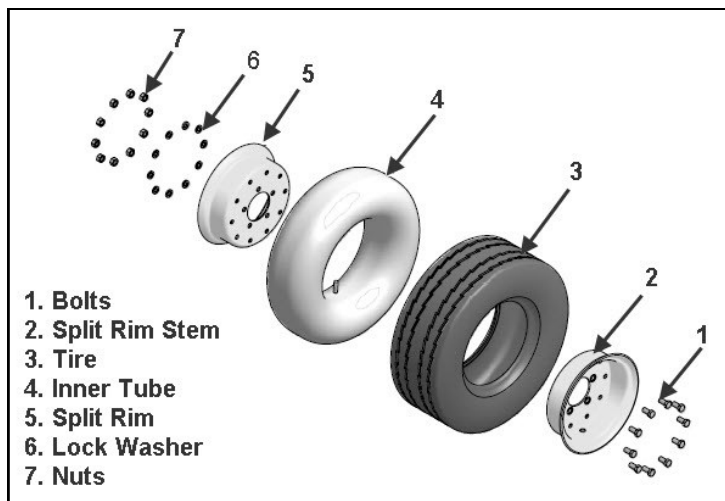

Figure 4-14 Wheel Assembly

4.19 Wheel Assembly

The Wheel assembly is a two-piece, split rim design. Use Figure 4-14 for the following maintenance steps.

- a. Remove wheel assembly as described in Section 4.5 for the side needing repair.
- b. Release air pressure from the inner tube by depressing stem valve or by removing the stem valve.
- c. Remove nuts (7), lock washers (6), and bolts (1).
- d. Separate split-rims (2) and (5) from tire (3).
- e. Remove inner tube (4) from tire (3). When reassembling, make sure that the inner tube stem is positioned through access hole in split-rim.
- f. Torque nuts (7) to 75-foot-pounds before applying air pressure to wheel.
- g. Torque lug nuts to 100-foot-pounds.

SECTION 5.0

PARTS BREAKDOWN DRAWINGS AND PART NUMBERS

The following figures are supplied to assist in component identification and parts reordering. When reordering, ensure the complete model number and serial number are provided to the sales representative.

You may access customer service by contacting Spokane Stainless Technologies, Inc. at 509-921-8850. If you would like more information about the Spokane Stainless Technologies, Inc. products you may visit the website at

www.spokanestainless.com.

DRAWING NUMBER

- 1.0 Overview, Component Identification**
- 2.0 Manway Assembly**
- 3.0 Telescoping Funnel Assembly**
- 4.0 Front Undercarriage**
- 5.0 Rear Undercarriage and Axle**
- 6.0 Front Hub Assembly**
- 7.0 Rear Hub & Drum Assembly**
- 8.0 Wheel & Tire Assembly**

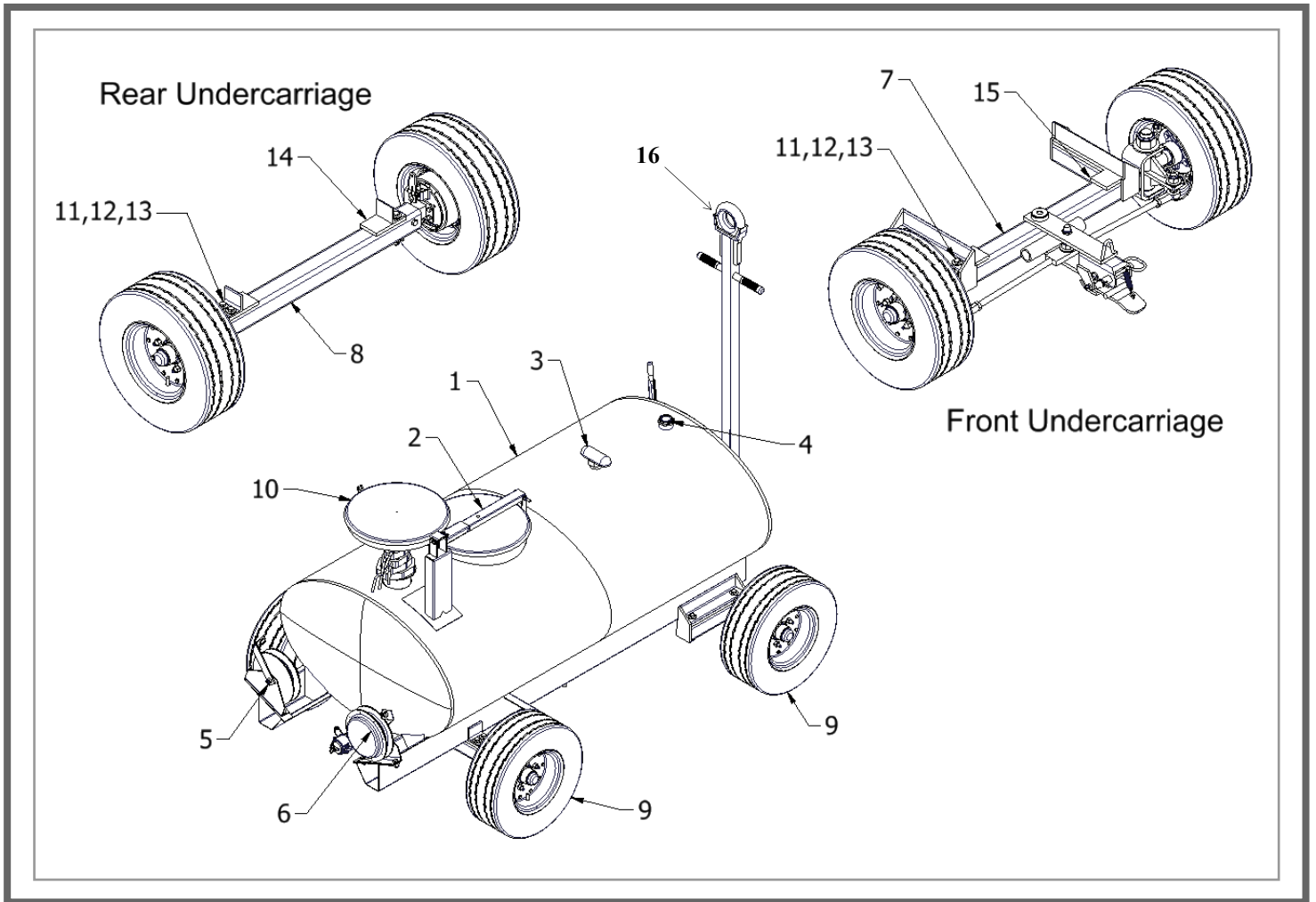

DRAWING 1.0 Overview, Component Identification

ITEM	QTY	P.N.	DESCRIPTION	MATERIAL	WEIGHT
1	1	-	Non-Vac Tank Weldment	Stainless Steel	-
2	1	08-10251	Cross Arm and Lid Assembly	Stainless Steel	15.75 lb.
3	1	04-1037	T-Vent, 1/2 Inch	Various	.08 lb.
4	1	-	Liquid Level Gauge	Various	9.39 lb.
5	1	04-10361	Grounding Reel With Plug	Various	9.39 lb.
6	1	08-10361R	Grounding Reel With Clamp	Various	9.39 lb.
7	1	-	Front Undercarriage	Various	126.01 lb.
8	1	-	Rear Undercarriage	Various	182.16 lb.
9	4	07-10201-1	Wheel, Tire and Tube Assembly	Various	31.90 lb.
10	1	08-1034U	Telescoping Funnel	Steel, Mild	20.21 lb.
11	8	02-3087	Nut, Nylon Insert, 1/2" UNC	Steel, Mild	.05 lb.
12	8	02-3025	Hex Bolt, 1/2" UNC x 4 1/2" LG	Steel Mild	.31 lb.
13	8	02-3125	Washer, Flat, 1/2-IN	Steel Mild	.30 lb.
14	2	06-1012	Rear Mounting Pad	Rubber	.75 lb.
15	2	06-1023	Front Mounting Pad	Rubber	1.5 lb.
16	1	07-1103-1	Tow Bar	Mild steel	33.8 lb.

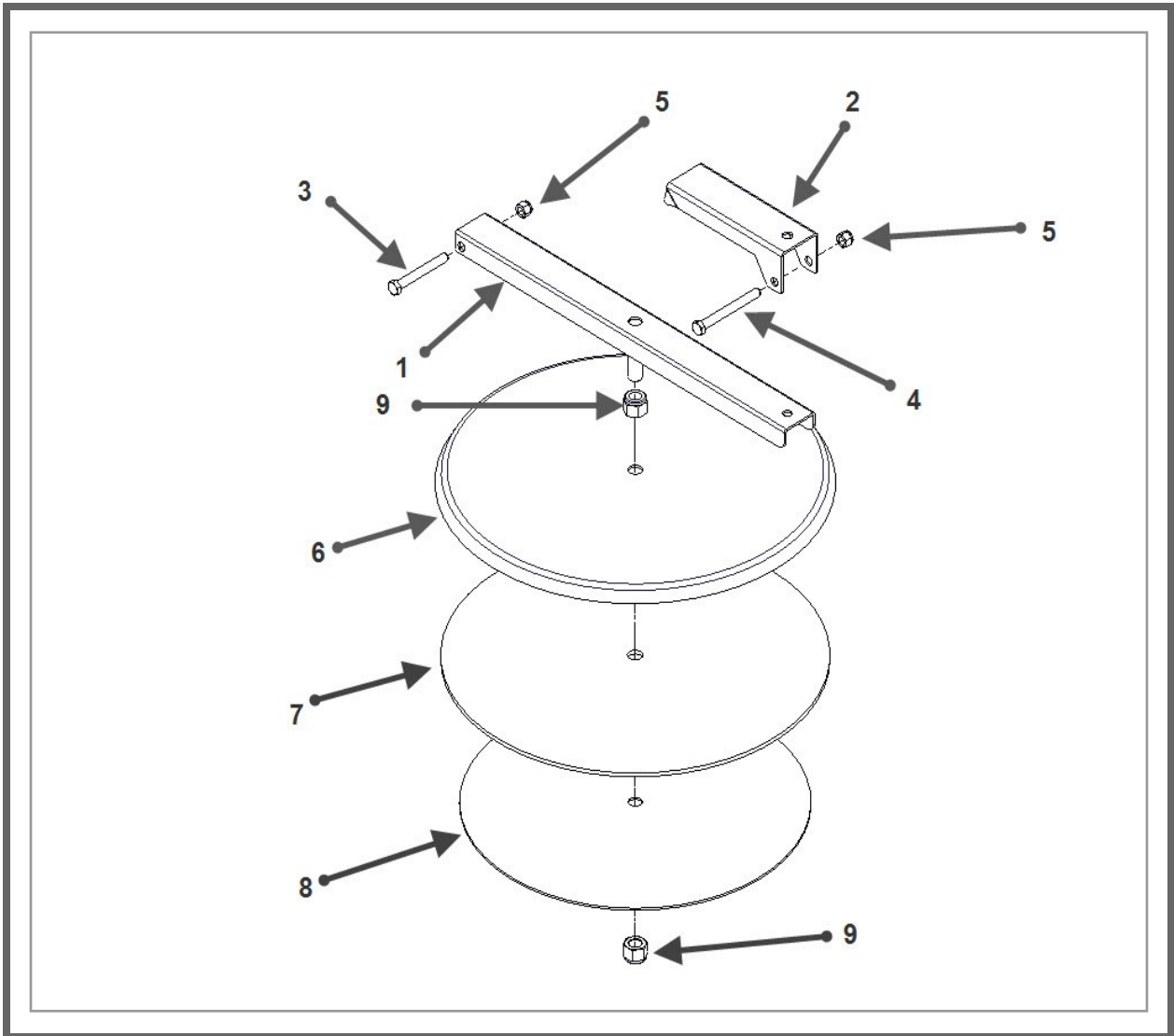

Drawing 2.0

Manway Assembly

ITEM	QTY	P.N.	DESCRIPTION
1	1	07-1039S	Cross Arm
2	1	01-8222S	Flip Lock
3	1	02-3044	Bolt, 3/8-16 x3 " LG (AP)
4	1	02-3045	Bolt, 3/8-16 x3 1/2 " LG (AP)
5	2	02-3089	Nut, Nylon Insert, 3/8-16 (AP)
6	1	01-86001	Manway Lid, 16"
7	1	06-25025	Manway Gasket
8	1	01-8710	Retainer Gasket, SV
9	2	02-3091	Nut, Nylon Insert

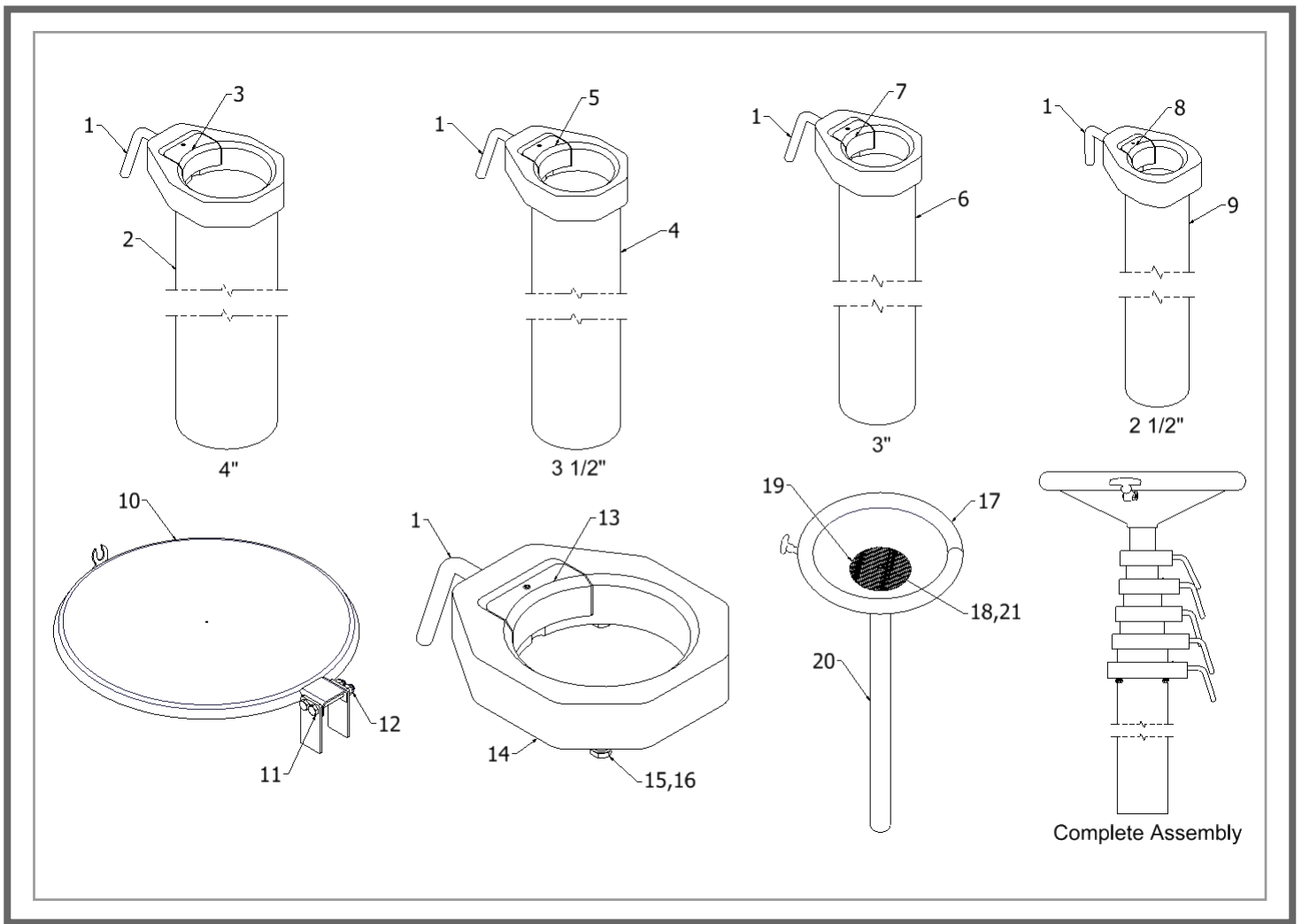

Drawing 3.0

Telescoping Funnel Assembly

ITEM	QTY	P.N.	DESCRIPTION
	1	08-1034U	Telescoping Funnel Asm.
1	5	05-10181	Handle
2	2	07-1014U	4" Tube (16 Ft.)
3	1	05-10041	Wedge, Clamp 3 1/2"
4	1	08-1028U (16 ft.)	3 1/2" Tube
5	1	05-10031	Wedge, Clamp 3"
6	1	08-1027U (16 ft.)	Tube, 3"x.065" Wall
7	1	05-10021	Wedge, Clamp 2 1/2"
8	1	05-10011	Wedge, Clamp 2"
9	1	08-1017U (16 ft.)	Tubing, .065" Wall, 2 1/2"
10	1	01-86002	Lid
11	1	02-3042	Hex Hd. Capscrew, NC, 3/8" by 3" LG

ITEM	QTY	P.N.	DESCRIPTION
12	1	02-3089	Nut, Nylon Insert 3/8" UNC
13	1	05-10051	Wedge, Clamp 4"
14	1	05-10302 (16 ft.)	Base Clamp
15	4	02-3138	Lockwasher 1/4"
16	4	02-3030	Hex Hd. Capscrew, NC, 1/4" by 5/8" LG
17	4	06-1022T	Gasket
18	1	02-3088	Nut, Nylock, NC, 1/4"-20
19	1	04-1039	Strainer
20	1	07-10541 (16 ft.)	Funnel Section
21	1	02-3000	Bolt, Carriage, 1/4" by 1" LG

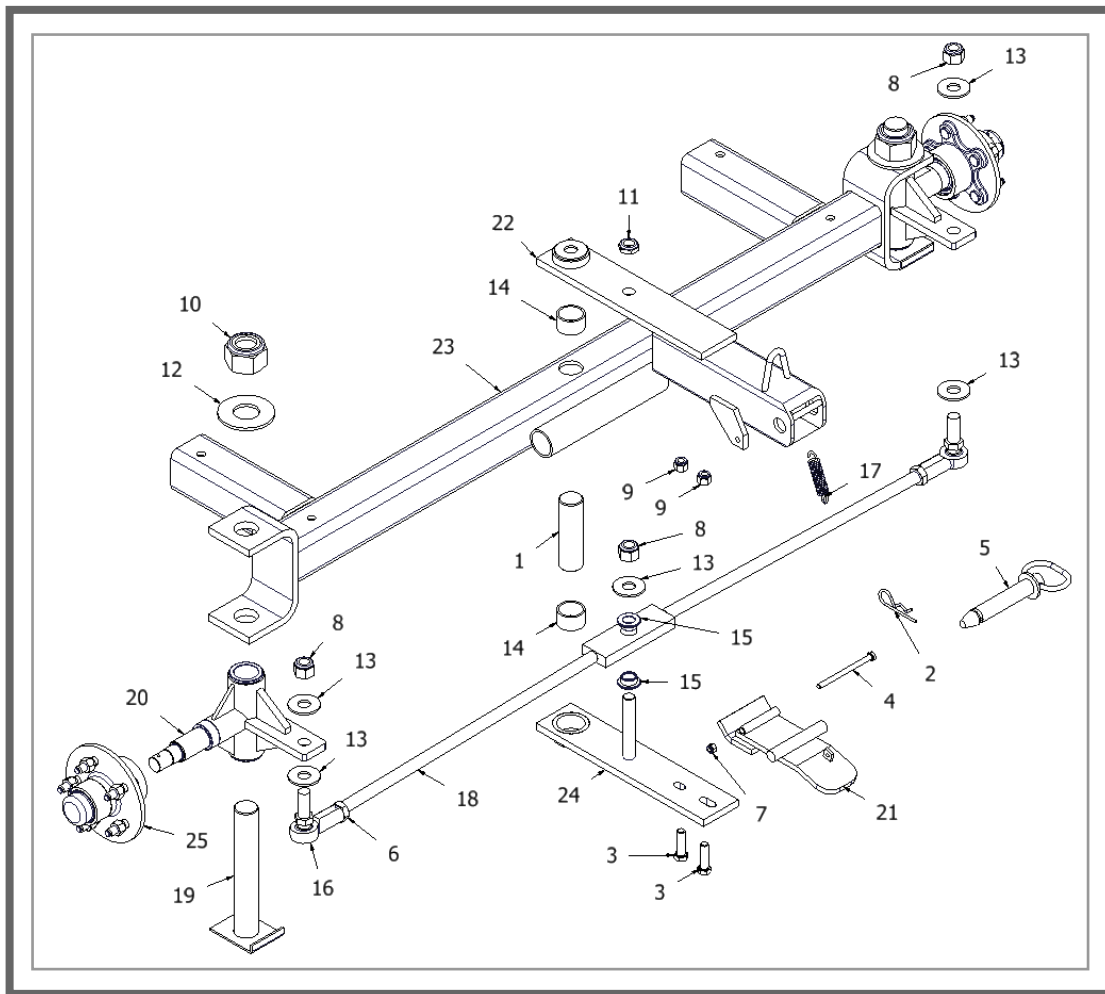

Drawing 4.0

Front Undercarriage

ITEM	QTY	P.N.	DESCRIPTION
1	1	01-8414	PIVOT PIN, FRONT AXLE
2	1	02-3016	HITCH PIN CLIP
3	2	02-3022	HEX HD CAPSCREW, NC, 1/2-IN BY 1 3/4-IN, GRD 5, PLATED
4	1	02-3055	HEX HD CAPSCREW, NC, 5/16-IN BY 4 1/2-IN LG, PLATED
5	1	02-3063	HITCH PIN, 1-IN BY 4 1/2-IN LG, PLATED
6	2	02-3081	NUT, JAM, UNF, 3/4-IN-16, PLATED
7	1	02-3082	NUT, NYLOCK, NC, 5/16-IN-18
8	3	02-3083	NUT, NYLOCK, NF, 3/4-IN-16
9	2	02-3087	NUT, NYLOCK, NC, 1/2-IN-13, FIN, PLATED
10	2	02-3093	NUT, NYLOCK, UNF, 1 1/2-IN-12, FIN
11	1	02-3094	NUT, NYLOCK, NF, 3/4-IN-16, FIN, THIN
12	2	02-3127	WASHER, FLAT, 1 1/2-IN, PLATED

ITEM	QTY	P.N.	DESCRIPTION
13	5	02-3131	WASHER, FLAT, 3/4-IN, PLATED
14	2	03-1014	BUSHING, STEERING ARM
15	2	03-1015	BUSHING, TIE ROD, PIVOT POINT
16	2	03-1016	ROD END, BALL JOINT LINKAGE
17	1	04-1054	SPRING, TOW LATCH
18	1	07-1005	TIE ROD ASSEMBLY, 400/600 GALLON
19	2	07-10105	KING PIN
20	2	07-1015	ASM., KING PIN
21	1	07-1020	TOW LATCH WMT, ALL SIZES
22	1	07-1104	STEERING ARM, UPPER, 400 & 600 GALLON
23	1	07-11071	FRONT AXLE WELDMENT, 400 & 600 GALLON
24	1	07-5002	STEERING ARM, LOWER PLATE, ALL SIZES
25	2	08-1011	FRONT HUB ASSEMBLY

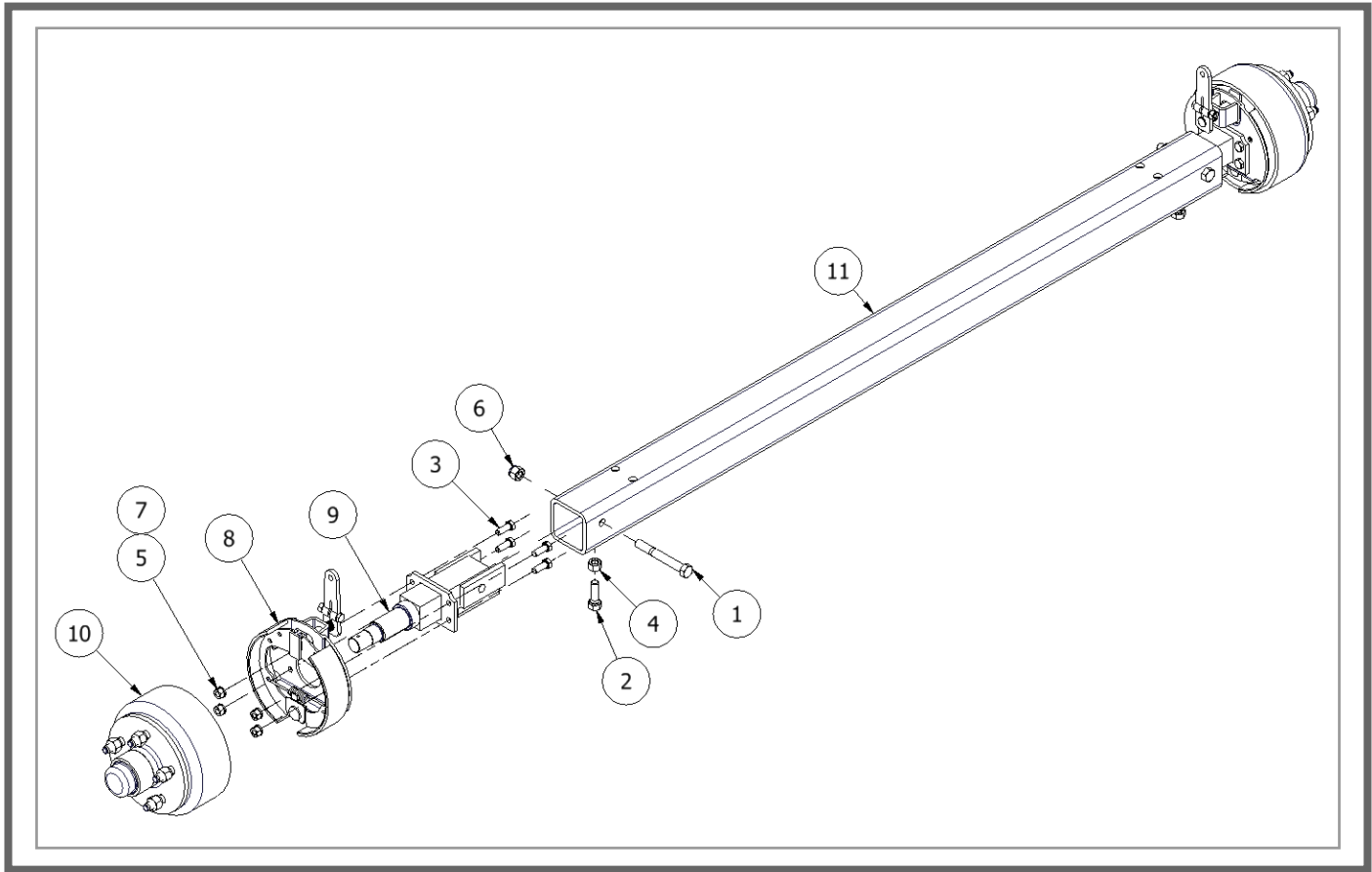

Drawing 5.0

Rear Undercarriage and Axle

ITEM	QTY	P.N.	DESCRIPTION
1	2	02-3024	HEX HD CAPSCREW, NC, 1/2-INCH BY 4-INCH, GRD 5, PLATED
2	2	02-3026	HEX HD CAPSCREW, NC, 1/2-INCH BY 1 1/2-INCH, GRD 5, PLATED
3	8	02-3050	HEX HD CAPSCREW, NC, 3/8-INCH BY 1-INCH, GRD 5, PLATED
4	2	02-3068	NUT, HEX, 1/2"-13 UNC PLATED
5	8	02-3072	NUT, HEX, NC, 3/8-IN-16, FIN., PLATED
6	2	02-3087	NUT, NYLOCK, NC, 1/2-INCH-13, FIN., PLATED
7	8	02-3143	WASHER, MEDIUM LOCK, 3/8-INCH PLATED
8	2	04-1063RBO	BRAKE ASSEMBLY
9	2	07-1010	REAR SPINDLE WELDMENT, REAR AXLE
10	2	08-10111	REAR HUB & DRUM ASSEMBLY
11	1	08-103011	REAR AXLE WELDMENT, 400 & 600 GALLON

- Not Illustrated

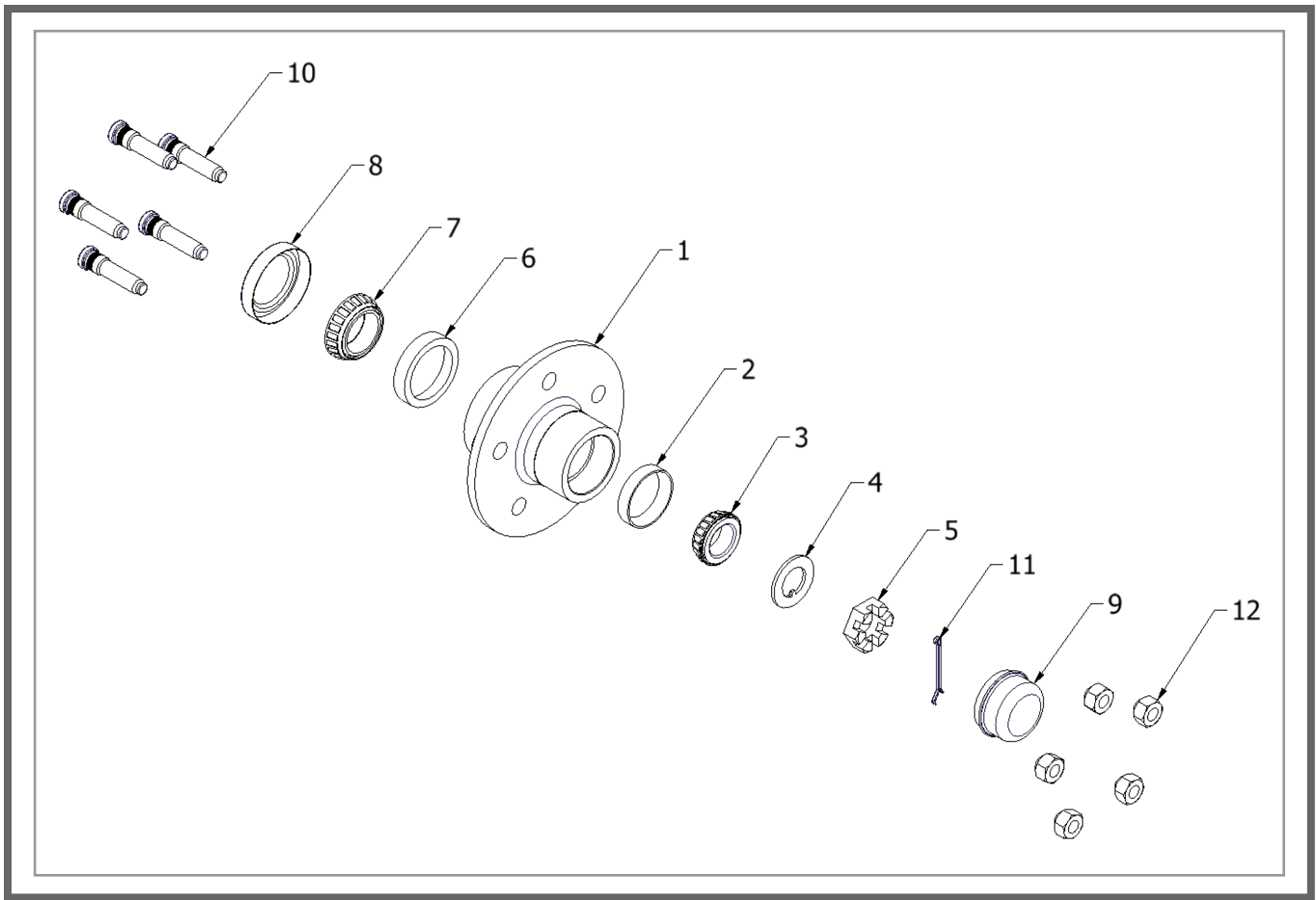

Drawing 6.0 Front Hub Assembly

ITEM	QTY	P.N.	DESCRIPTION
	1	08-1011	Front Hub Assembly
1	1	04-1017	Hub, Front Axle
2	1	04-1016	Cup, Outer Bearing
3	1	04-1014	Cone, Outer Bearing
4	1	02-12055	Washer
5	1	02-1205	Nut, Castle
6	1	04-1015	Cup, Inner Bearing
7	1	04-1013	Cone, Inner Bearing
8	1	04-1012	Seal Bearing
9	1	04-1019	Cap, Hub
10	5	02-1017	Stud
11	1	02-1303	Pin, Cotter
12	5	02-3065	Nut, lug, 1/2"

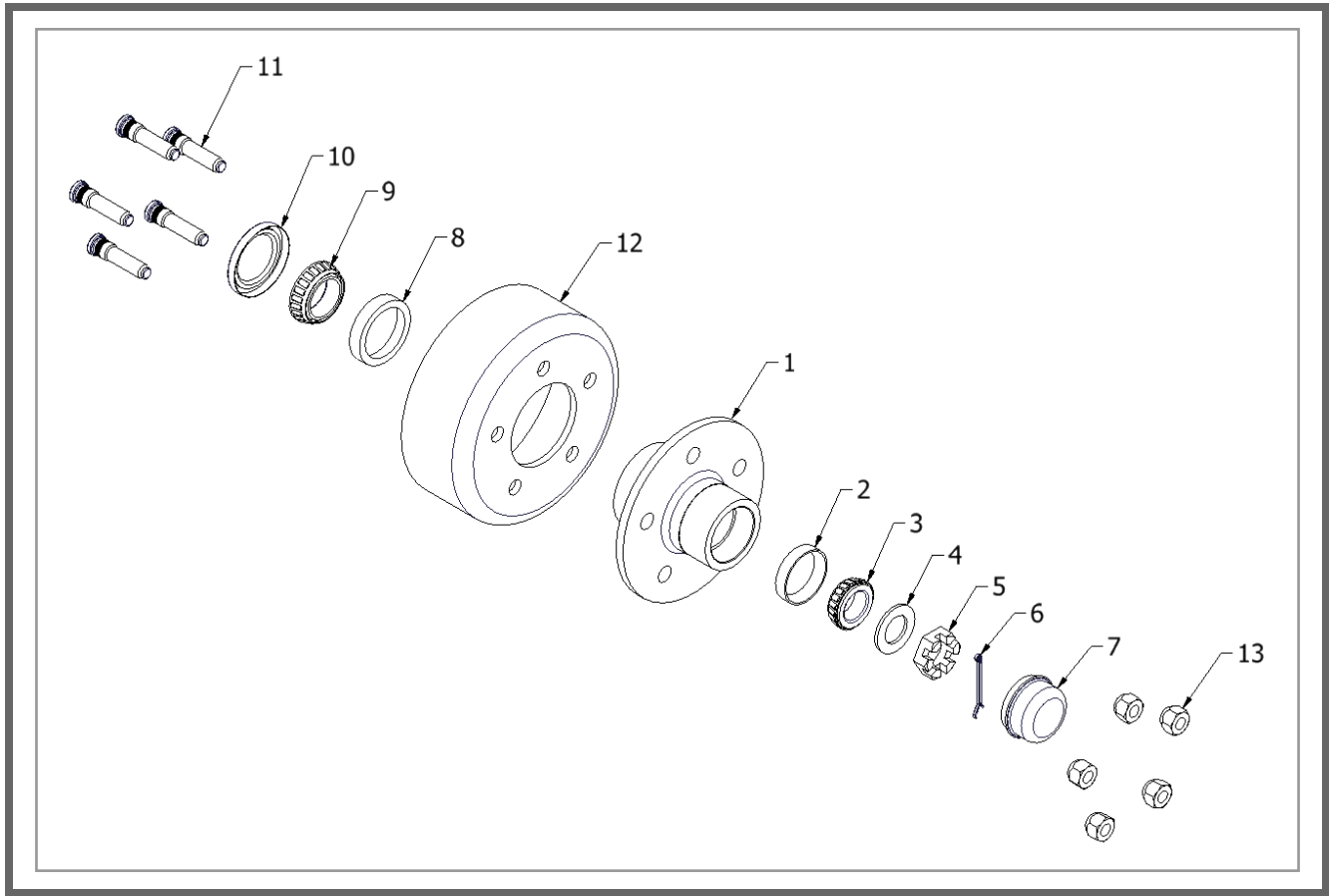

Drawing 7.0

Rear Hub and Drum Assembly

ITEM	QTY	P.N.	DESCRIPTION
	2	08-10111	Rear Hub & Drum Assembly
1	1	04-1017	Hub, Rear Axle
2	1	04-1016	Cup, Outer Bearing
3	1	04-1014	Cone, Outer Bearing
4	2	02-12055	Washer
5	1	02-1205	Nut, Castle
6	1	02-1303	Pin, Cotter
7	2	04-1019	Cap, Hub
8	2	04-1015	Cup, Inner Bearing
9	1	04-1013	Cone, Inner bearing
10	1	04-1012	Seal, Bearing
11	5	02-1303	Stud
12	1	08-10111-002	Drum, Brake
13	5	02-3065	Nut Lug

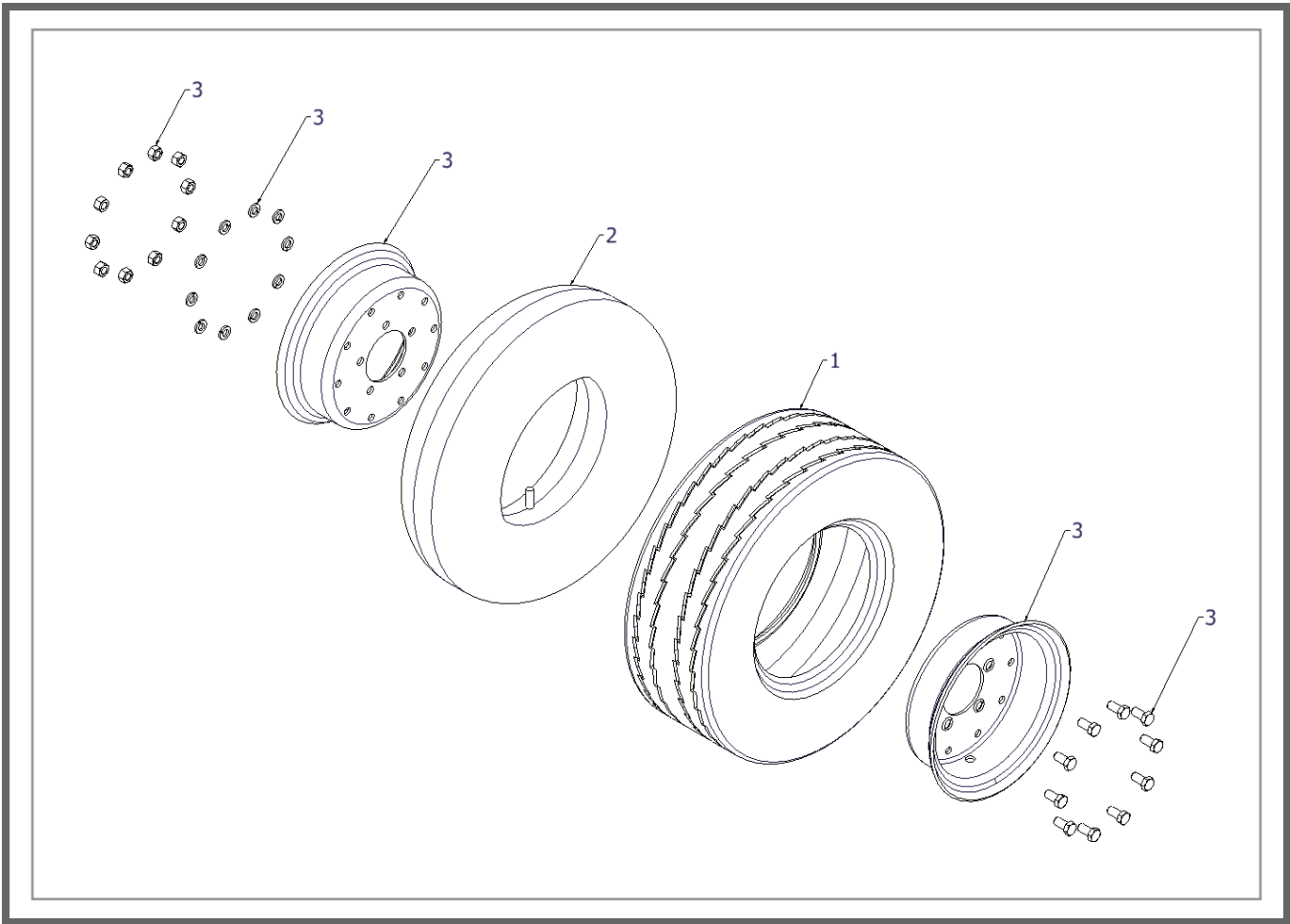

Drawing 8.0

Wheel and Tire Assembly

ITEM	QTY	P.N.	DESCRIPTION
	4	07-10201-1	Complete Wheel Assembly (All Numbers)
1	1	04-10221	Tire, 20.5x 8.0-10, E-Range
2	1	04-1059	Inner Tube
3	2	04-1020	Split Rim Wheel Assembly