

SPOKANE INDUSTRIES, INC.
Spokane Metal Products Division
Spokane, Washington

CONFIDENTIAL PROPRIETARY INFORMATION
Reproduction of this data or the manufacturing of products from
This data by anyone other than Spokane Industries, Inc. of Spokane,
Washington is strictly prohibited without written consent.

**400 GALLON FUEL BOWSER
TECHNICAL MANUAL
PARTS, OPERATION AND MAINTENANCE
MODEL # NV 400**

© COPYRIGHT 2000 BY SPOKANE INDUSTRIES INC.
ALL RIGHTS RESERVED

This document discloses subject matter in which Spokane Industries, Inc. has Proprietary rights and such subject matter shall not, without the written permission of Spokane Industries, Inc. be either (A) used, released or disclosed in whole or in part outside the government, (B) used in whole or in part by the government, for manufacture, or (C) used by a party other than the government, except for (1) emergency repair or overhaul work only, by or for the government, where the item or process concerned is not otherwise reasonably available to enable timely performance of the work, provided that release of disclosure hereof outside the government shall be made subject to a prohibition against further use, release of disclosure, or (2) release to a foreign government, or for emergency repair or overhaul work by or for such government under the conditions of (1) above. This legend shall be marked on any reproduction hereof in whole or in part.

400 GALLON FUEL BOWSER

TECHNICAL MANUAL

PARTS, OPERATION AND MAINTENANCE

MODEL NUMBER NV 400

INDEX

	<u>Page</u>
<u>Section 1.</u> Introduction	1
<u>Section 2.</u> Safety	1
<u>Section 3.</u> Operation	
3.1 Intended Use	2
3.2 Parking Brake	2
3.3 Tow Bar and Under Carriage	2
3.6 Grounding Reels	3
3.7 Drain Valve	3
3.8 Sample Port	3
3.10 Vent Overflow Preventor	4
<u>Section 4.</u> Maintenance	
4.1 Parking Brake	4
4.2 Under Carriage and Tow Bar	5
4.5 Grounding Reels	5

<u>Section 5.</u>	Replacement Parts	6
5.1	Main Tank	7
5.2	Under Carriage	
	Axle, Front	9
	Axle, Rear	12
	Brake, Parking	14
	Wheel Assembly, Front	16
	Wheel Assembly, Rear	18
5.3	Manway Assembly	20
5.4	Decal Package	21
5.7	Miscellaneous Fixtures	23
5.9	Vent, Overflow Preventor	25
<u>Warranty</u>	26

- 1.1 To obtain optimum benefit from your fuel bowser unit, it is recommended that all personnel operating it read and understand this manual prior to operation.
- 1.2 Upon receipt of the Bowser unit, a visual inspection should be made to determine that it is complete and has not sustained any damage during transportation.

2.0 SAFETY

2.1 Potential Fire Or Explosion

2.1.1 Due to the nature of fuel, care should be exercised to eliminate all sparks and open flame in the area of the fuel bowser.

2.1.2 A 50 foot radius area around the fuel bowser for no smoking, sparks, or open flames is usually a good practice. It is strongly recommended all local or other regulations be consulted for further restrictions.

2.3 Grounding

2.3.1 To eliminate static sparks, the bowser unit is equipped with two grounding reels which should be connected prior to draining or filling operations.

2.4 Towing

2.4.1 Make sure the tow bar is securely attached to the towing vehicle.

2.4.2 Before moving the bowser unit, check to assure the parking brake is released.

2.4.3 Maximum allowable towing speed is 15 MPH.

2.5 Parking

2.5.1 Parking brake must be applied when filling and draining or when left unattended.

2.7 Inspections

2.7.1 Inspection of tires, undercarriage, tow bar, vent, valves, hoses, sight gauge, reflectors, safety labels, etc., should be inspected on a periodic basis. It is recommended these inspections be performed weekly.

2.7.2 Internal inspection will be necessary to insure structural integrity and cleanliness. It is recommended that interval inspections be performed at least every (6) six months. Caution! When entering confined spaces such as the interior of the bowser tank, care should be taken to provide proper breathing equipment and a separate person dedicated solely to a safety watch of the person inside. It is strongly recommended that all local or other regulations be consulted.

3.0 OPERATION

3.1 Intended Use

3.1.1 The fuel bowser unit is intended for use in draining and collection of fuel from aircraft and the transportation to a disposal site. Any other use is prohibited and may void any and all warranties.

3.2 Parking Brake

3.2.1 The bowser unit is equipped with a mechanically operated parking brake. The brake should be applied prior to disengaging tow bar. The brake should be applied when filling, or draining tank, or whenever left unattended.

3.3 Tow Bar and Undercarriage

3.3.1 The bowser unit is equipped with steerable front wheels controlled by the tow bar.

3.3.2 Care should be taken not to jackknife the bowser when backing up.

3.3.3 Tire inflation should be checked and maintained as described in the maintenance section.

3.3.4 Before towing, check to see the brake is disengaged, grounding reel and hoses are disconnected, valves are closed, tow bar is securely attached to the towing vehicle, telescoping drain is collapsed, and all manways and covers are closed and latched.

3.3.5 The bowser unit is equipped with a tow bar latch to hold it in the upright position.

3.6 Grounding Reels

3.6.1 The bowser unit is supplied with two grounding reels.

3.6.2 Before filling, draining, or vacuuming, the grounding reels must be attached to the aircraft or object being serviced and an appropriate ground.

3.7 Drain Valves

3.7.1 The bowser unit is equipped with a 1-1/2" NPT ball valve with a camlock connector.

3.8 Sample Port

3.8.1 The bowser unit is equipped with a 1/2" NPT valve for use as a sample port.

3.7 Drain Valves

3.7.1 The bowser unit is equipped with a 1-1/2" NPT ball valve with a camlock connector.

3.8 Sample Port

3.8.1 The bowser unit is equipped with a 1/2" NPT valve for use as a sample port.

3.10 Vent Overflow Preventor

3.10.1 The bowser unit is equipped with a float actuated seal to prevent fuel from flowing out the vent in the event the bowser is overfilled.

4.0 MAINTENANCE

4.1 Parking Brake

4.1.1 The bowser unit is equipped with a parking brake assembly consisting of a 7" diameter brake drum with 1-3/4" wide brake shoes.

4.1.2 The shoes are activated via a mechanical linkage, eccentric and lever.

4.1.3 Adjustment may be necessary as the shoes wear.
(1) Tightening is accomplished by removing the bolt through one yoke and screwing yoke in to shorten connecting rod.
(2) Do not over tighten or brakes may drag when released.

4.1.4 Replacement of shoes.
(1) Remove wheel.
(2) Remove nut retaining hub and drum assembly.
(3) Disconnect actuating rod.
(4) Remove shoe retainers.
(5) Install new shoes.
(6) Replace shoe retainers.
(7) Adjust actuator rod length.
(8) Replace wheel.

4.2 Under Carriage and Tow Bar

4.2.1 The bowser unit is equipped with steerable front wheels, fixed rear wheels, and a tow bar.

4.2.2 Maintenance should consist of the following:

- (1) King pin bushing, turning bushings and tie rod ends are self lubricating and need no additional maintenance.
- (2) Inspect wheel bearing at (3) month intervals. Repack and, or replace as needed.
- (3) Check tire pressure weekly. Pressure should be maintained at 60 PSI.

4.2.3 Tow bar pivot pin and hook ring should be inspected monthly for excessive wear or cracks.

4.5 Grounding Reels

4.5.1 Grounding reel cables should be pulled out, cleaned and inspected monthly.

4.5.2 Cable clamps and ends should be inspected for loose connections monthly.

4.6 Sight Gauge

4.6.1 The sight gauge should be inspected monthly for loose connections and weathering of clear tubing.

5.0 REPLACEMENT PARTS

This section provides information for identification of parts for ordering. To order, it is important to have the Model Number, Subassembly Number, Part Number and Description. Parts may be ordered by calling or writing to:

SPOKANE METAL PRODUCTS
P.O. Box 3303
Spokane, WA 99220-3303
Telephone: (509)928-0720
Tele Fax:(509)927-0826

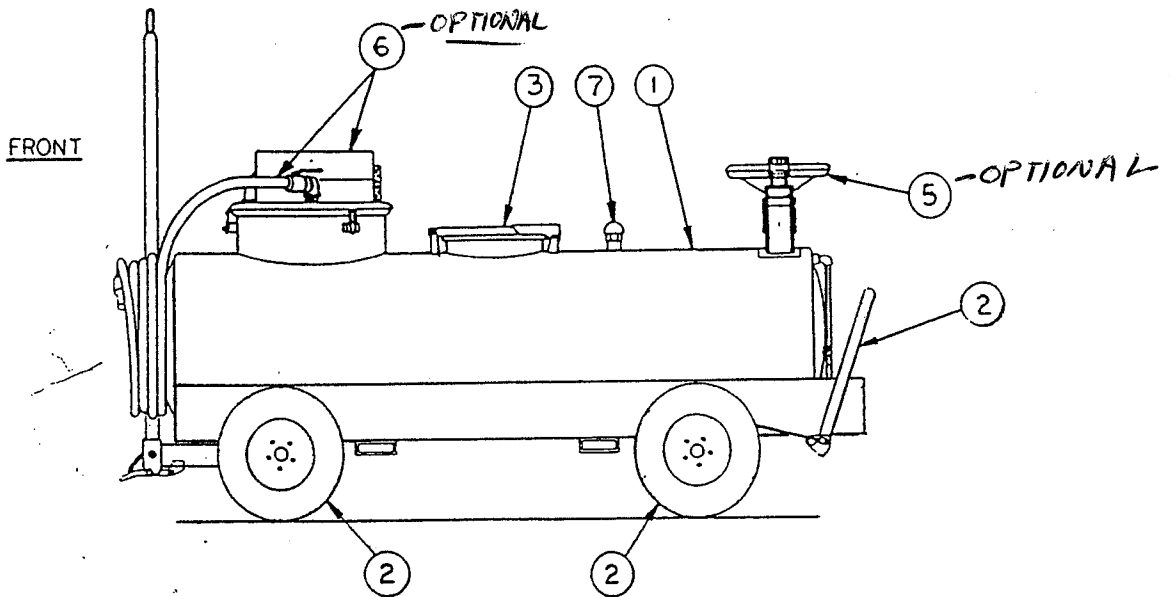
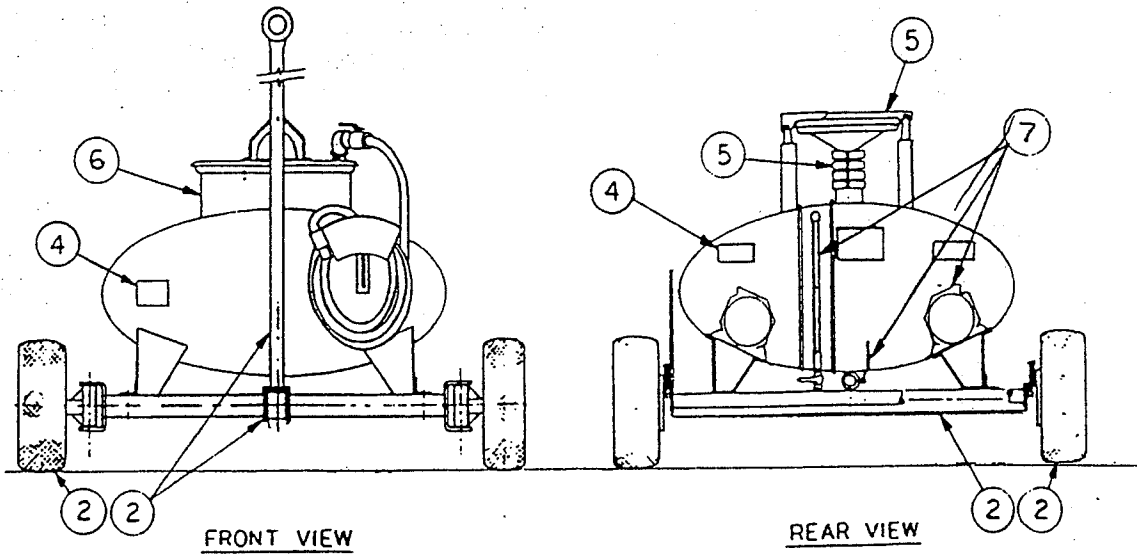

Item No.

Section

1	Main Tank	5.1
2	Axle, Front	5.2.1
2	Axle, Rear	5.2.2
2	Brake, Parking	5.2.3
2	Wheel Assembly, Front	5.2.4
2	Wheel Assembly, Rear	5.2.5
3	Manway Assembly	5.3
4	Decal Package	5.4
5	Telescoping Drain (OPTIONAL ITEM)	
6	Vacuum Assembly (NOT AVAILABLE ON NV UNITS)	
7	Miscellaneous Fixtures	5.7
7	Vent, Overflow Preventor	5.8

CONFIDENTIAL PROPRIETARY INFORMATION
 . Reproduction of this data or the manufacturing of products from this data by anyone other than
 Spokane Metal Products of Spokane, WA is strictly prohibited without written consent.

SECTION 5.1

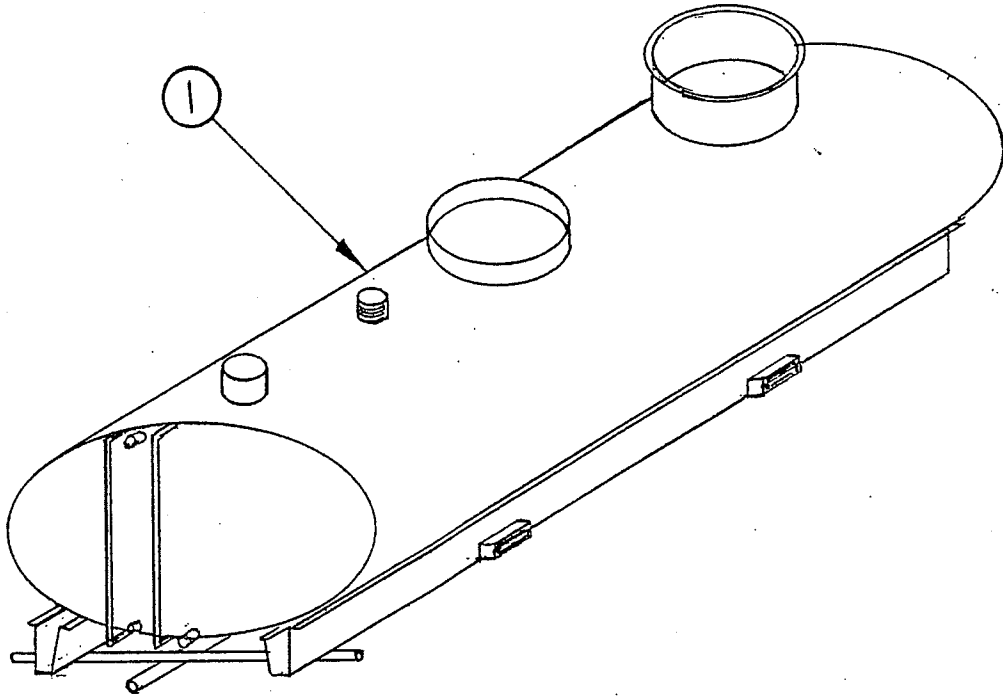

ASSEMBLY NO. 08-10009

MAJOR ASSEMBLY - TANK WELDMENT

Sub Assy.	Item	Part No.	Quantity	Description	Wt. #
	1	08-10009	1	Stainless Steel Tank Weldment, 400 Gallon Capacity	1120

SECTION 5.2.1

CONFIDENTIAL PROPRIETARY INFORMATION
 REPRODUCTION OF THESE DRAWINGS OR THE MANUFACTURING OF PRODUCTS FROM THESE
 DRAWINGS FOR USE BY ANYONE OTHER THEN SPOKANE METAL PRODUCTS OF SPOKANE, WA
 IS STRICTLY PROHIBITED WITHOUT WRITTEN CONSENT.

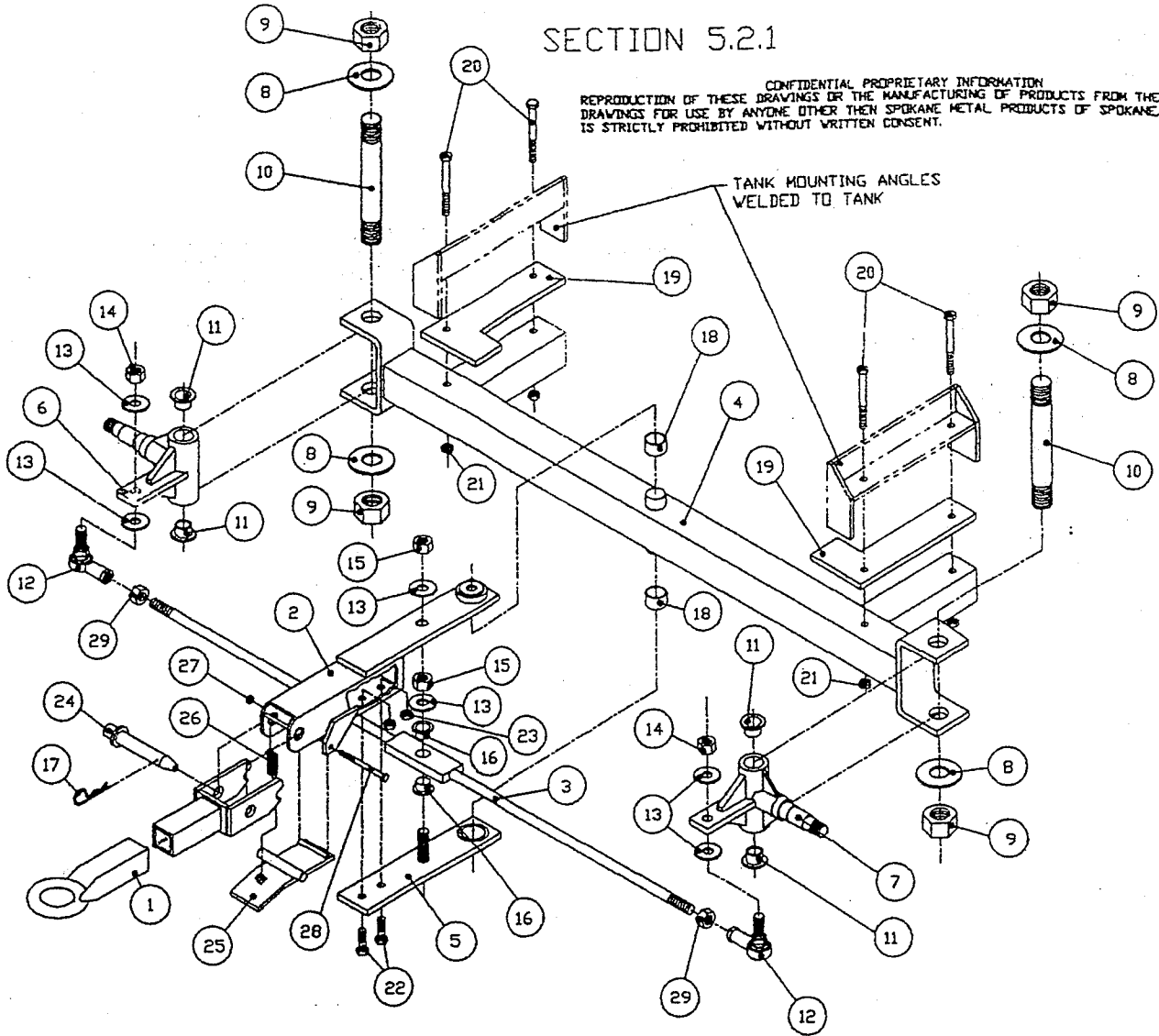

ASSEMBLY NO. 08-1018

MAJOR ASSEMBLY - AXLE ASSEMBLY

Sub Assy.	Item	Part No.	Quantity	Description	Wt. #
08-1018				Axle, Assembly, Front	145.0
	1	07-1103	1	Tow Bar	23
	2	07-1104	1	Arm, Turning	16
	3	07-1005	1	Tie Rod	7.3
	4	07-11071	1	Axle, Front	53

ASSEMBLY NO 08-1018

MAJOR ASSEMBLY - AXLE ASSEMBLY (CONTINUED)

Sub Assy.	Item	Part No.	Quantity	Description	Wt. #
	5	07-1016	1	Steering Arm, Lower Plate	6.1
	6	05-1009	1	Sleeve, King Pin, Right	24
	7	05-1009	1	Sleeve, King Pin, Left	24
	8	02-11131	4	Washer, King Pin	1
	9	02-12131	4	Nut, King Pin	2
	10	05-1010	2	King Pin	11
	11	03-1013	4	Bushing, King Pin Sleeve	1
	12	03-1016	2	Ends, Tie Rod	5
	13	02-11072	5	Washers, Tie Rod	
	14	02-12071	2	Nuts, Tie Rod Ends	1
	15	02-12071	1	Nut, Tie Rod Pivot	.5
	16	03-1015	2	Bushing, Tie Rod Pivot	.8
	17	02-1300	2	Cotter Pin	.2
	18	03-1014	2	Bushing, Axle Pivot	1
	19	06-1023	2	Mounting Pad, Tank	4
	20	02-1503	4	Bolts, Tank Mounting	1.3
	21	02-12041	4	Nuts, Tank Mounting	.5
	22	02-1502	2	Bolts, Turning Arm Clamp	.32
	23	02-12041	2	Nuts, Turning Arm Clamp	.2
	24	02-1304	1	Hitch Pin	2
	25	07-1020	1	Toe Latch	3.1

ASSEMBLY NO. 08-1018

MAJOR ASSEMBLY - AXLE ASSEMBLY (CONTINUED)

Sub Assy.	Item	Part No.	Quantity	Description	
	26	04-1054	1	Spring, Toe Latch	.5
	27	02-1201	1	Nut, Toe Latch	.1
	28	02-1501	1	Bolt, Toe Latch	.2
	29	02-12141	2	Hex Nut, Tie Rod	.2

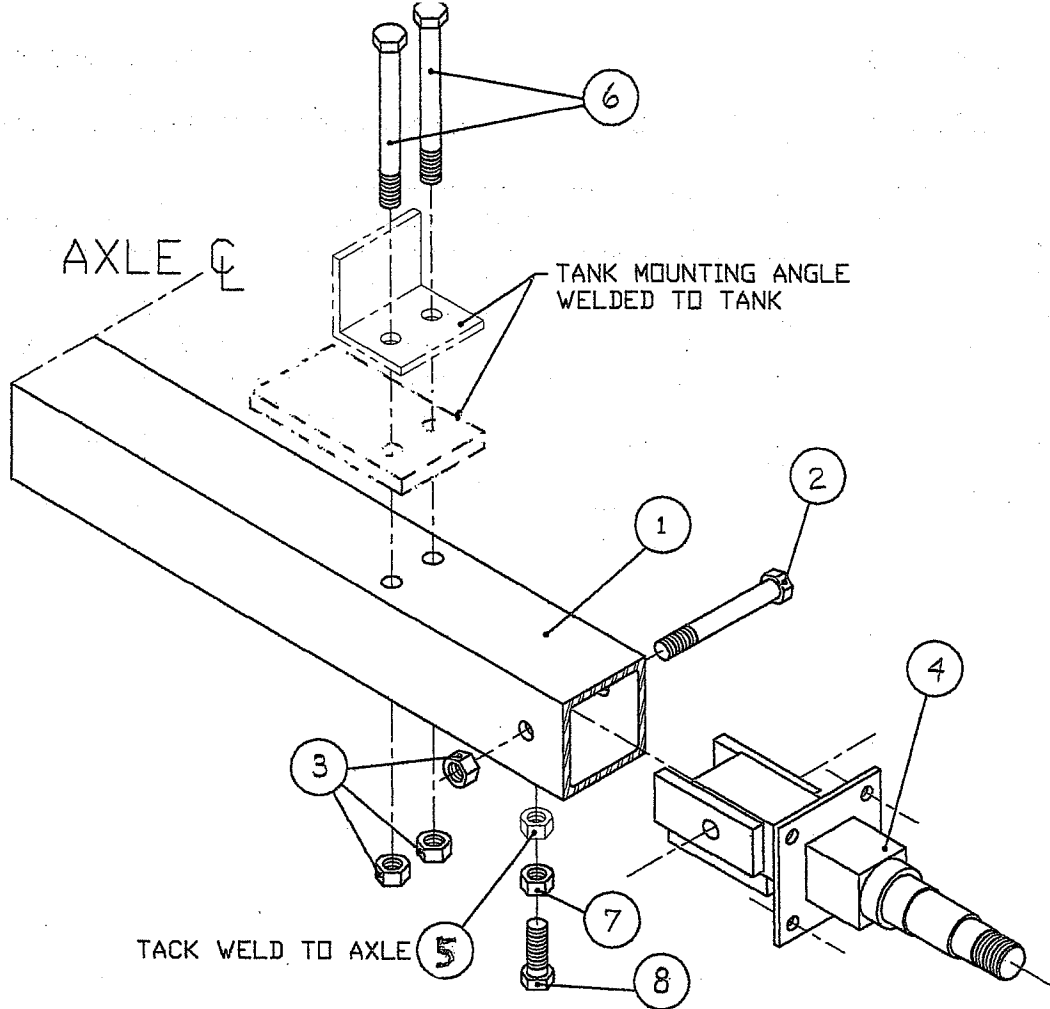

ASSEMBLY NO. 08-10102R
 MAJOR ASSEMBLY - AXLE ASSEMBLY

Sub. Assy.	Item	Part No.	Qty.	Description	Wt.
08-10102R				Axle Assembly, Rear	
	1	05-1023	1	Axle, Rear Weldment	40
	2	02-1505	2	Bolts, Mounting Spindle	.6
	3	02-12041	2	Nuts, Mounting Spindle	.5
	4	07-1010R	2	Spindle, Rear	17
	5	02-12035	1	NUT, JAM	.1
	6	02-1503	4	Bolt, Tank Mounting	1.3
	7	02-1203	4	Nuts, Tank Mounting	.5
	8	02-10041	2	Bolt, Spindle Stabilizer	.5

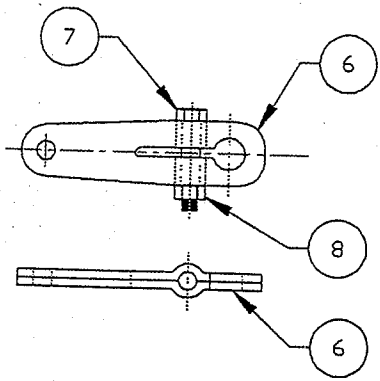

CAM LEVER OPERATOR DETAIL

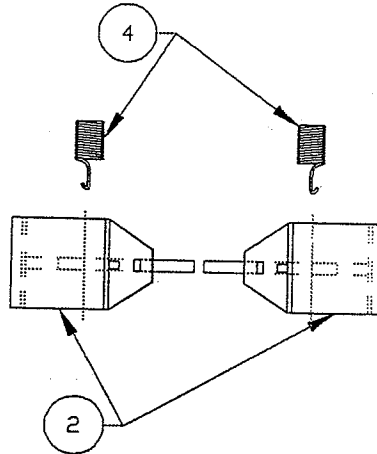

BRAKE SHOE / HOLD DOWN SPRING DETAIL

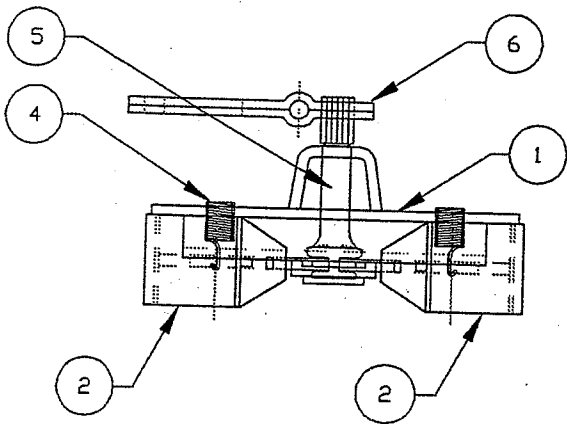

BRAKE/CAM/LEVER/BACKING PLATE ASSY

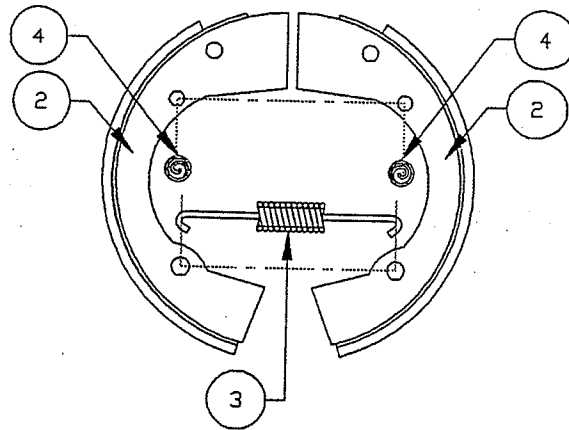

BRAKE SHOE / SPRING ORIENTATION
RETURN SPRING

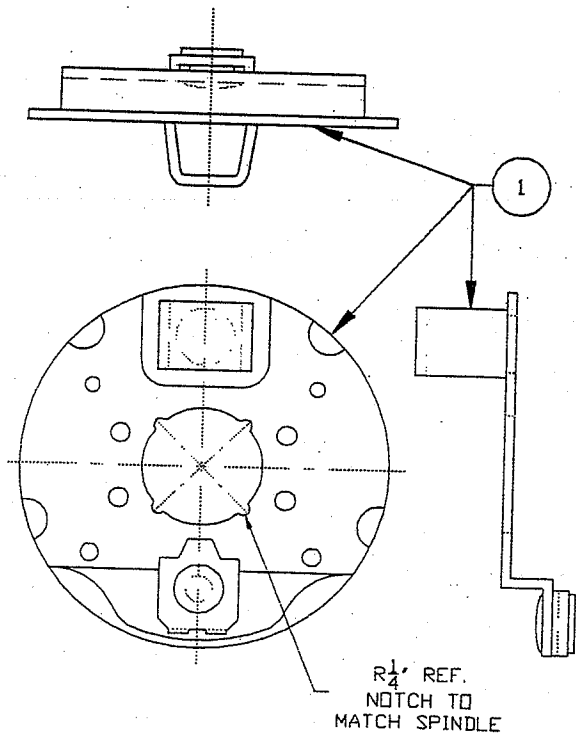

BACKING PLATE DETAIL

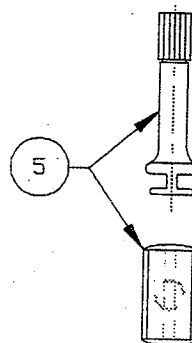

CAM DETAIL

SECTION 5.2.3
 CONFIDENTIAL-PROPRIETARY INFORMATION
 REPRODUCTION OF THESE DRAWINGS OR THE MANUFACTURING OF PRODUCTS FROM THESE
 DRAWINGS FOR USE BY ANYONE OTHER THAN SPOKANE INDUSTRIES INC. OF SPOKANE, WA
 IS STRICTLY PROHIBITED WITHOUT WRITTEN CONSENT

SECTION 5.2.3

CONFIDENTIAL-PROPRIETARY INFORMATION
REPRODUCTION OF THESE DRAWINGS OR THE MANUFACTURING OF PRODUCTS FROM THESE
DRAWINGS FOR USE BY ANYONE OTHER THAN SPOKANE INDUSTRIES INC. OF SPOKANE, WA
IS STRICTLY PROHIBITED WITHOUT WRITTEN CONSENT

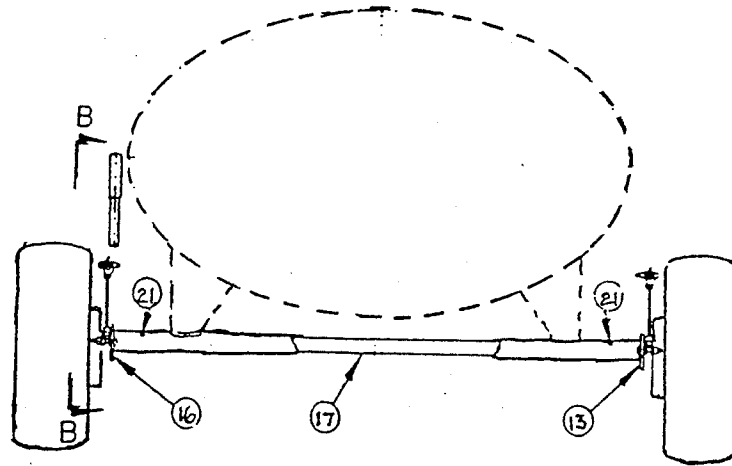

REAR VIEW

WTS

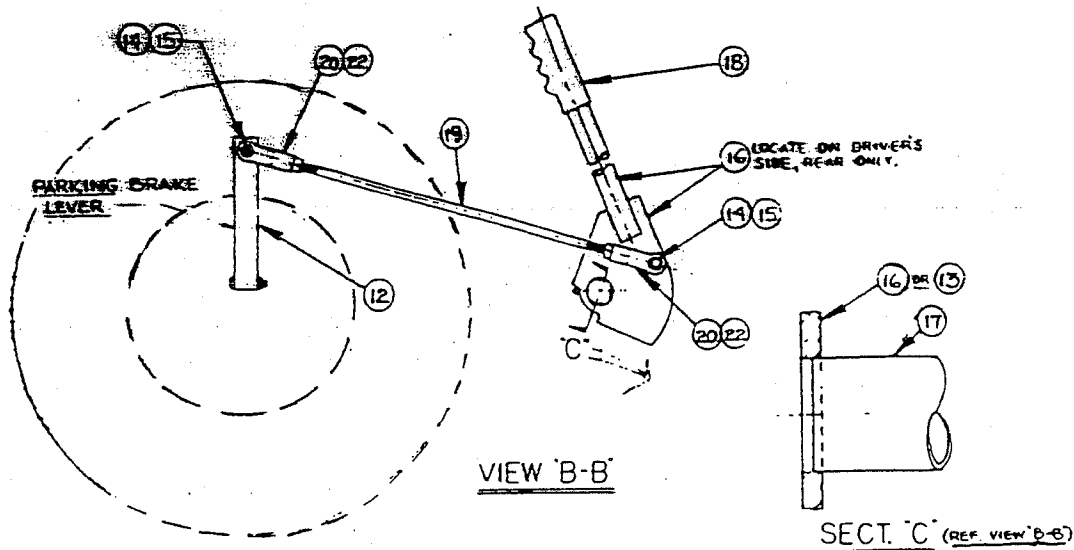

ASSEMBLY No. 10-100030R
MAJOR ASSEMBLY - BRAKE, PARKING

Sub Assy.	Item	Part No.	Quantity	Description	Wt. #
08-1007R		04-1063		Brake Assembly (2 Req.)	4.4
	1	04-1064R	1	Backing Plate Assembly	1.4
	2	04-1065R	2	Brake Shoe Assembly	1.6
	3	04-10265R	1	Return Spring	.04
	4	04-1026R	2	Hold Down Spring	.06
	5	04-1028R	1	Cam	.5
	6	04-1030R	1	Cam Lever	.7
	7	02-10017R	1	Cam Bolt	.07
	8	02-12012	1	Cam Nut	.03
	9				
	10				
	11				
	12				
08-1008				Brake Linkage Assembly	14.8
	13	05-1025	1	Cam, Brake Linkage	1.4
	14	02-10012	1	Bolt	.4
	15	02-12021	1	Nut	.1
	16	07-1033	1	Brake Handle, Fab'd Sub Assy	5.4
	17	01-8104	1	Brake Handle, Connector	4
	18	04-1055	1	Grip, Vinyl	1
	19	05-1026	1	Rod, Brake Linkage	1
	20	04-2516	4	Yoke Ends	.5
	21	03-1020	2	Grease Fitting	.5
	22	02-100231	4	Jam Nut	.5

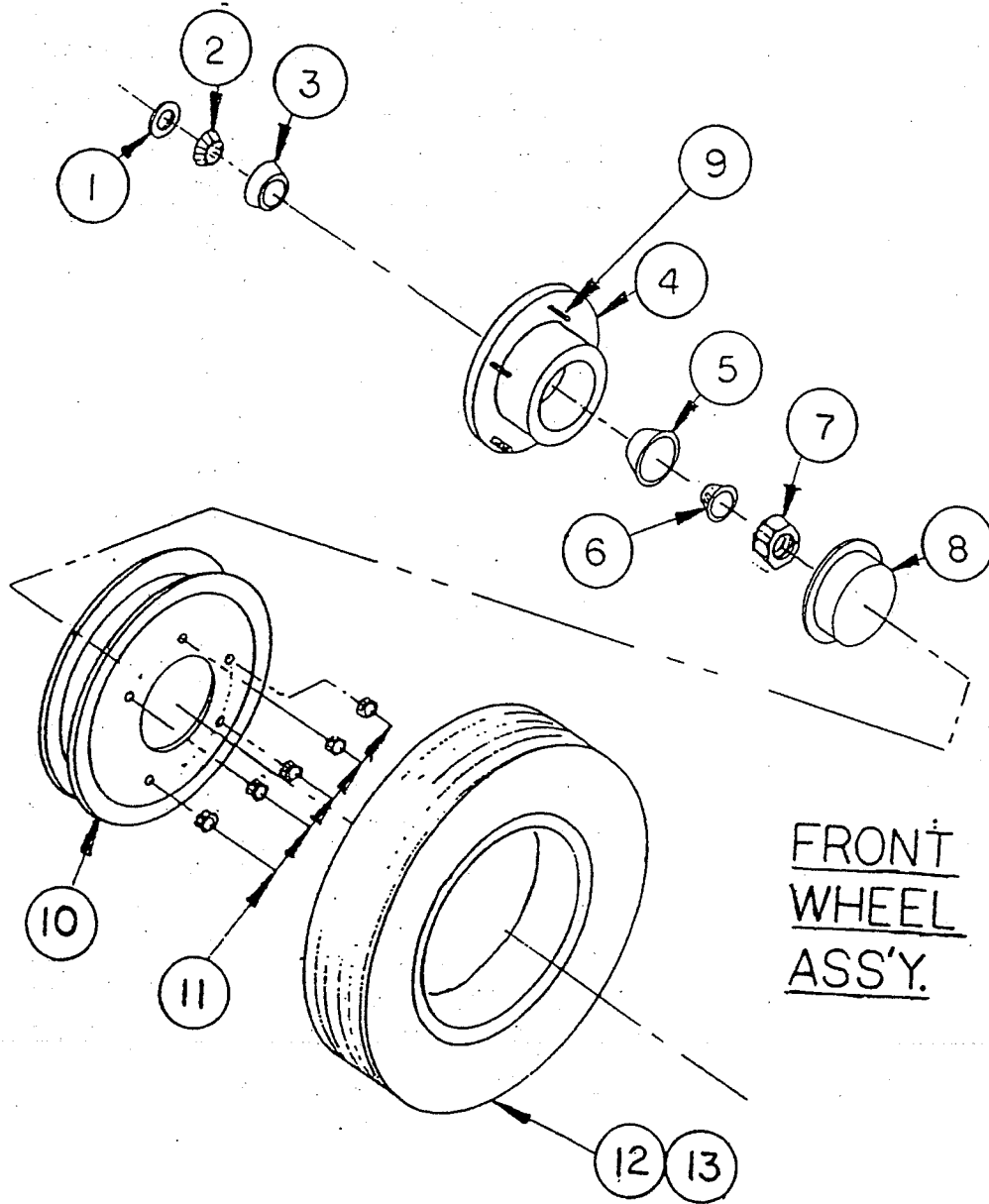

MAJOR ASSEMBLY - WHEEL ASSEMBLY, FRONT

Sub Assy.	Item	Part No.	Quantity	Description	Wt. #
08-1011		04-1050		Bearing & Hub Assembly (2 Reqd)	
	1	04-1012	1	Seal, Bearing	1
	2	04-1013	1	Bearing, Inner	3
	3	04-1015	1	Cup, Inner	2
	4	04-1017	1	Hub, Wheel	7
	5	04-1016	1	Cup, Outer	4
	6	04-1014	1	Bearing, Outer	3
	7	02-1205	1	Spindle Nut	1
	8	04-1019	1	Dust Cap	1
	9	02-1017	5	Studs, Hub	1
08-10061		04-10201		Tire/Wheel/Tube Assembly (2 Reqd)	
	10	04-1020	1	Wheel, Split Rim, 10"	9.5
	11	04-1021	5	Lug Nuts, Wheel	1
	12	04-10221	1	Tire, 10"	4
	13	04-1045	1	Tube Assembly	11

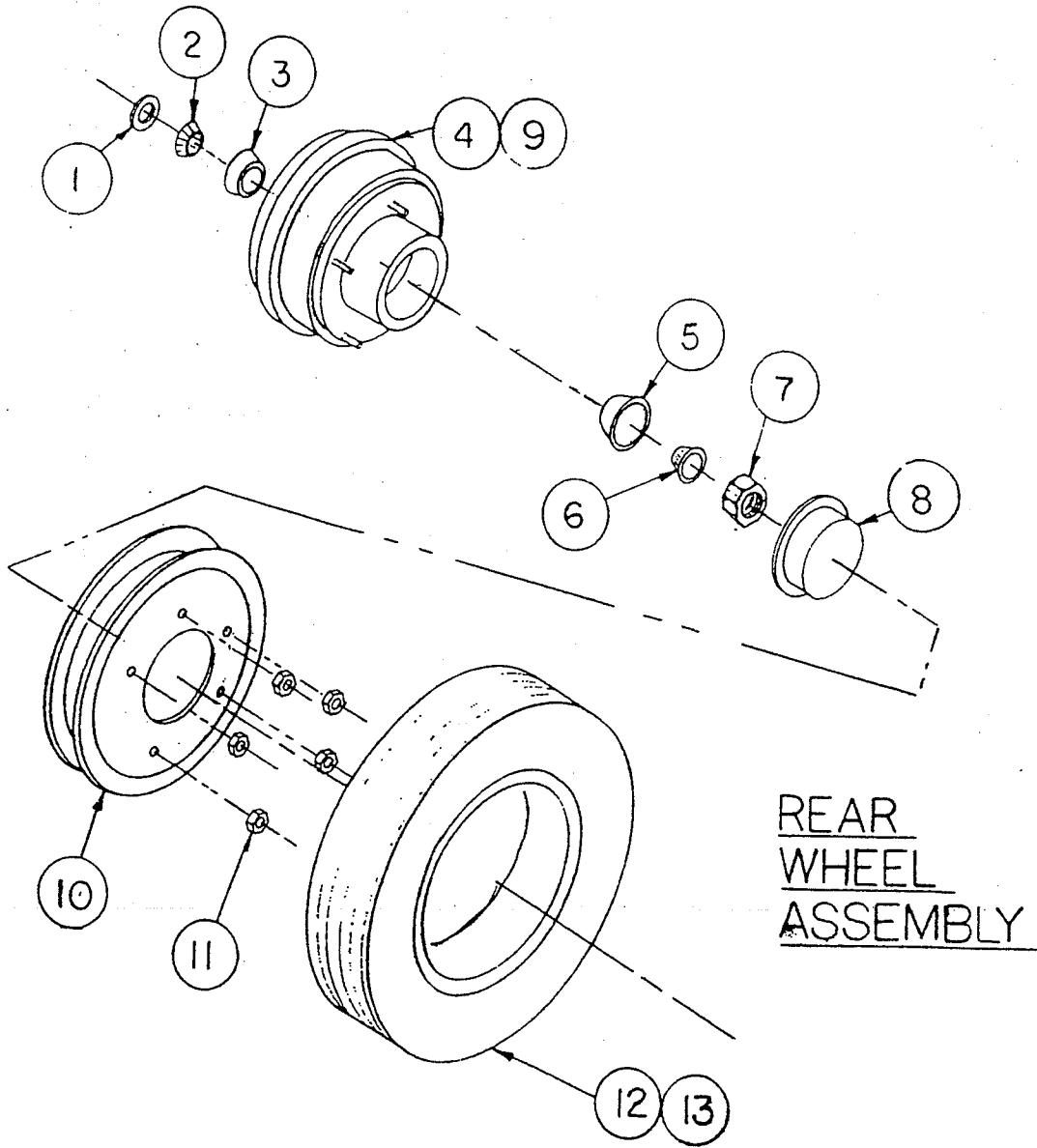

ASSEMBLY NO. 10-100052R

MAJOR ASSEMBLY - WHEEL ASSEMBLY, REAR

Sub Assy.	Item	Part No.	Quantity	Description	Wt.#
08-10111R		04-1062R		Bearing & Hub Assembly (2 Reqd)	
	1	04-1012	1	Seal, Bearing	1
	2	04-1013	1	Bearing, Inner	3
	3	04-1015	1	Cup, Inner	2
	4	05-1008R	1	Hub/Brake Drum Sub-Assy	16
	5	04-1016	1	Cup, Outer	4
	6	04-1014	1	Bearing, Outer	3
	7	02-1205	1	Nut, Spindle	1
	8	04-1019	1	Dust Cap	1
08-10061		04-1020		Tire/Wheel/Tube Assembly (2 Reqd)	
	10	04-10201	1	Wheel, Split Rim	9.5
	11	04-1021	5	Lug Nuts, Wheel	1
	12	04-10221	1	Tire, 10"	4
	13	04-1045	1	Tube Assembly	11

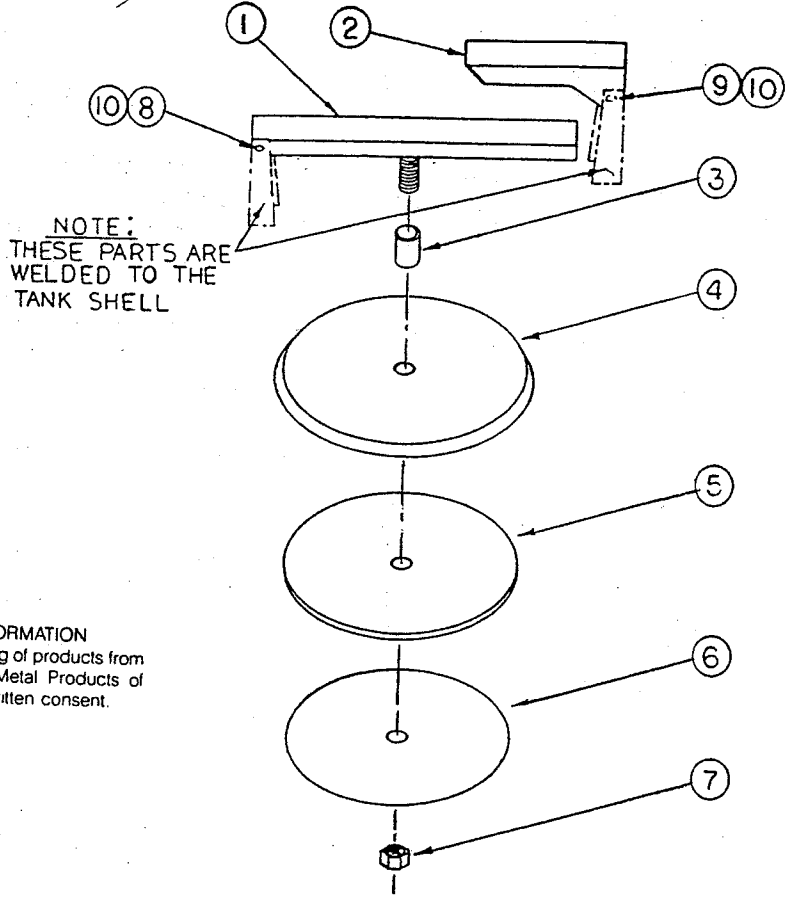

CONFIDENTIAL PROPRIETARY INFORMATION
 Reproduction of this data or the manufacturing of products from
 this data by anyone other than Spokane Metal Products of
 Spokane, WA is strictly prohibited without written consent.

ASSEMBLY NO. 10-100060

MAJOR ASSEMBLY - MANWAY ASSEMBLY

Sub Assy.	Item	Part No.	Quantity	Description	Wt. #
08-1025				Manway Cover Assembly	
	1	07-1039S	1	19-1/2" Cross Arm Sub-Assy	2.5
	2	01-8222S	1	7" Cross Arm	4
	3	01-93455S	1	Spacer	.5
	4	01-86001	1	Cover	5
	5	06-25025	1	Gasket	1
	6	07-2303	1	Gasket Retainer	2
	7	02-1206	1	Nut	.5
	8	02-10013	1	Bolt	1
	9	02-10014	1	Bolt	1
	10	02-1202	2	Nut	.5

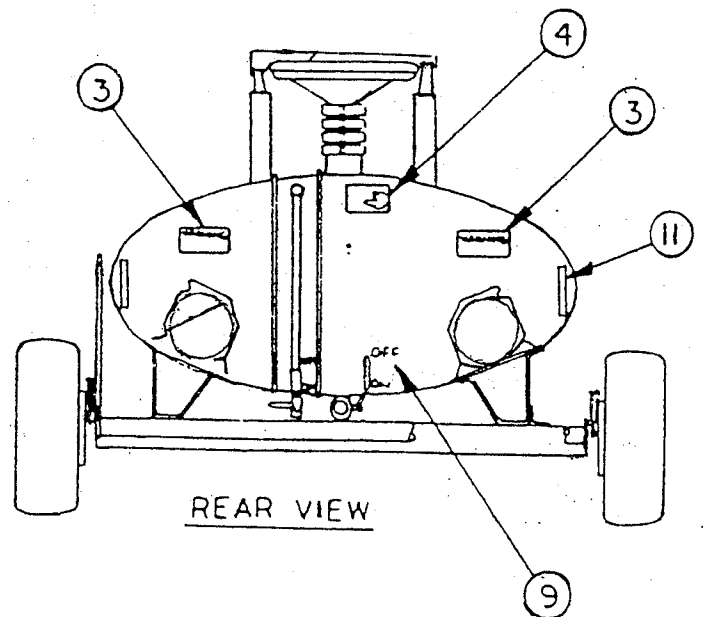
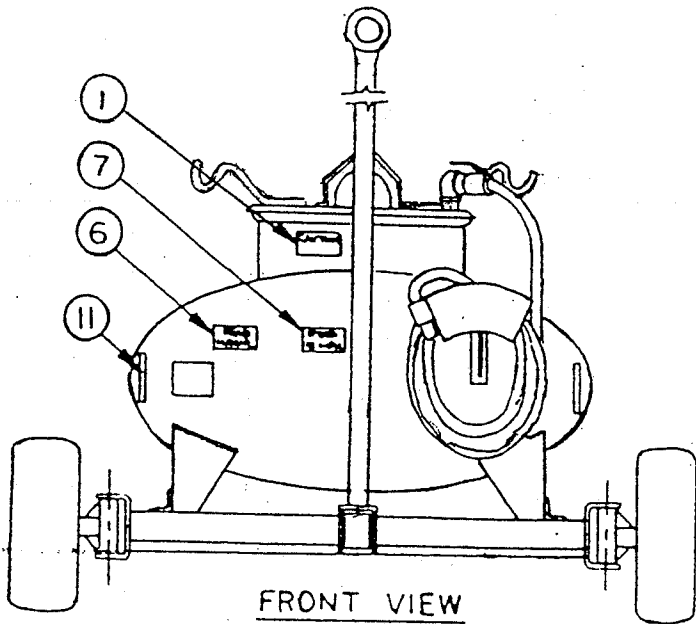
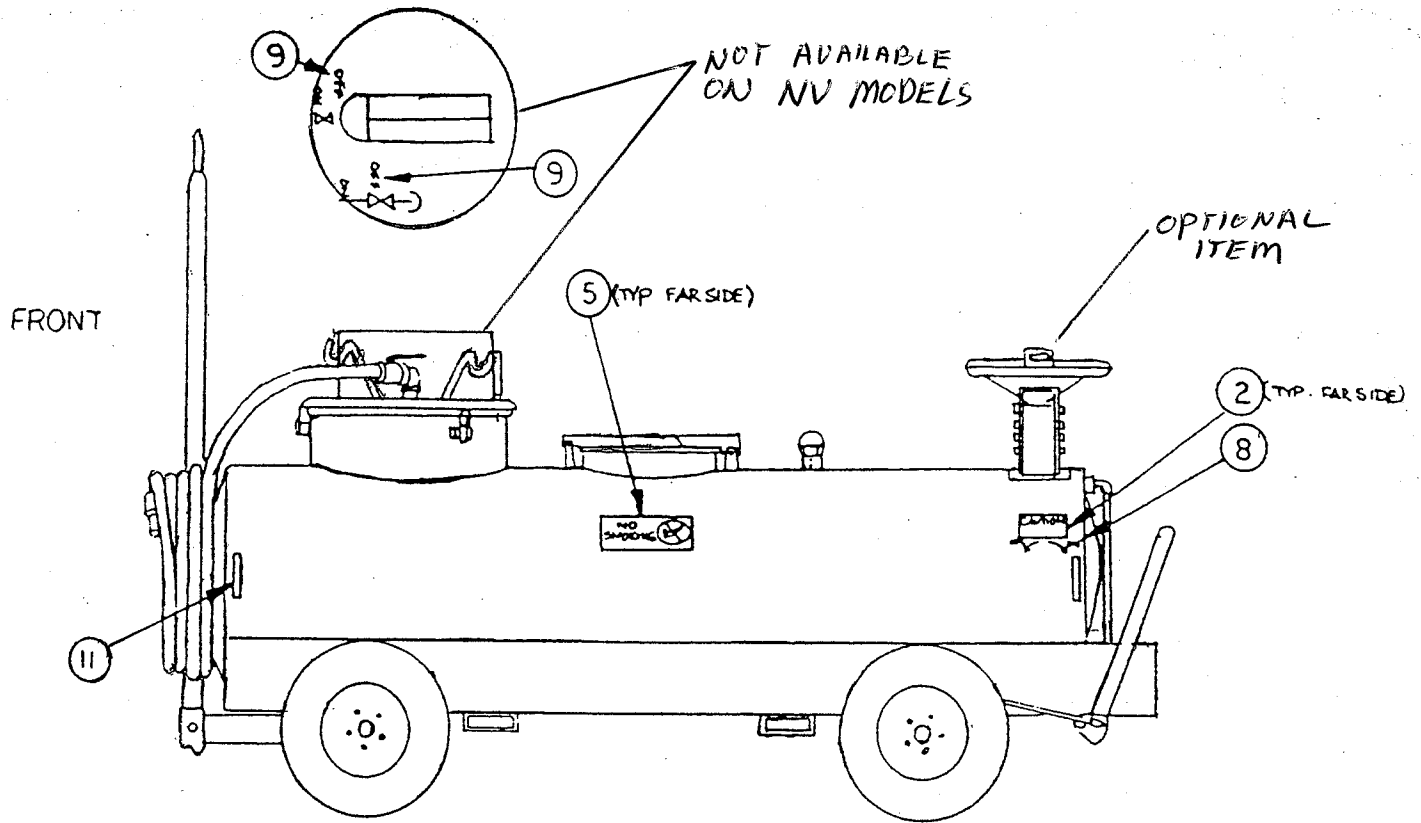

ASSEMBLY NO 10-100070
 MAJOR ASSEMBLY - DECAL PACKAGE

Sub Assy.	Item	Part No.	Quantity	Description	Wt.#
10-100070				Decal Assembly	.1
	1	06-1002	1	Caution, Vacuum System	.1
	2	06-1003	1	Caution, Parking Brake	.1
	3	06-1004	2	Warning, Grounding Reels	.1
	4	06-1005	1	Warning, Telescoping Drain	.1
	5	06-1006	2	Danger, No Smoking	.2
	6	06-1007	1	Notice, Read Manual	.1
	7	06-1008	1	Maximum Towing Speed 15MPH	.1
	8	06-1010	1	Off/On, Parking Brake	.1
	9	06-1011	8	Off/On, Drain Valve	.8
	11		8	Reflector Tape	.8

SECTION 5.7

CONFIDENTIAL PROPRIETARY INFORMATION
Reproduction of this data or the manufacturing of products from
this data by anyone other than Spokane Metal Products of
Spokane, WA is strictly prohibited without written consent

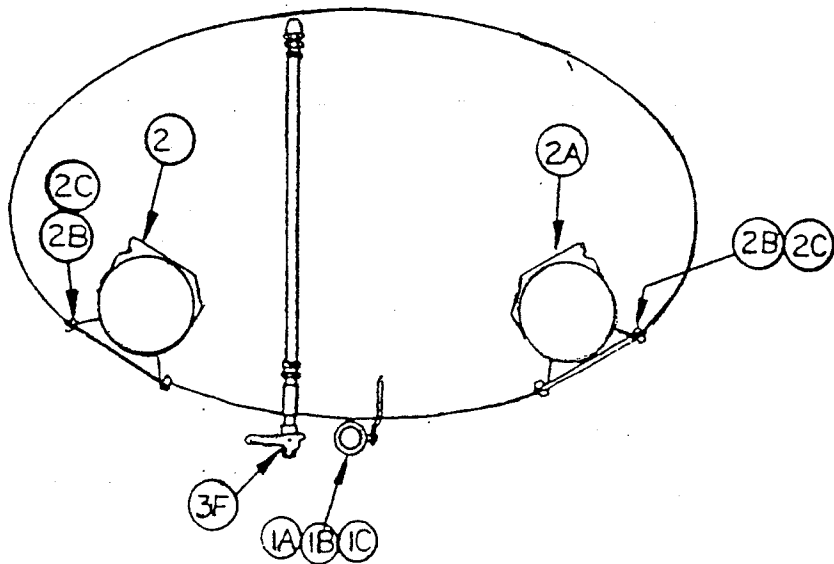
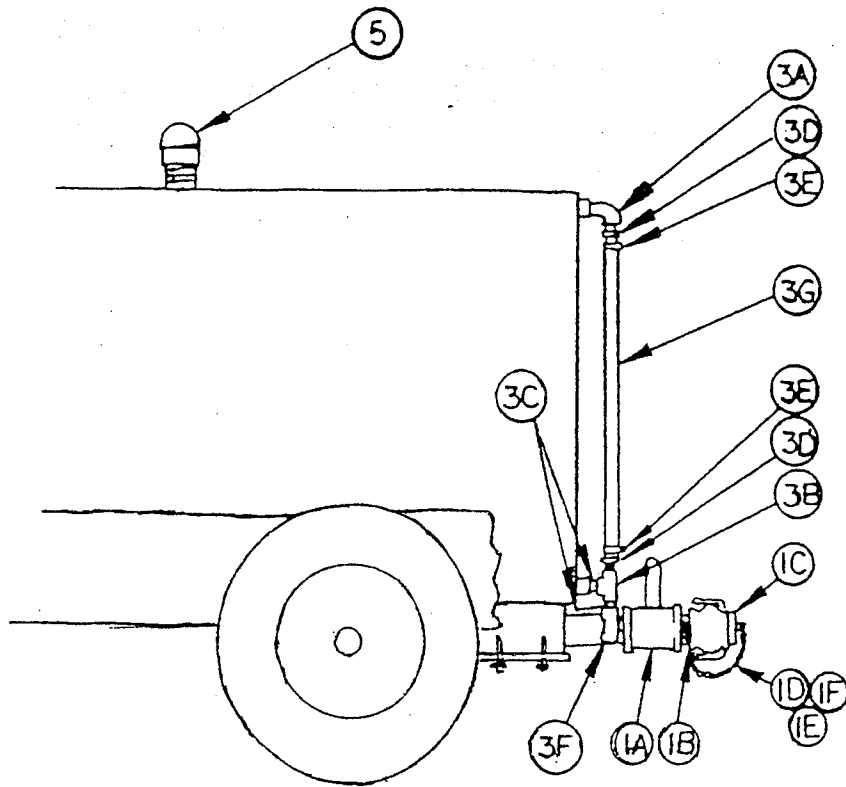

REAR VIEW

MAJOR ASSEMBLY - MISC. FIXTURES

Sub Assy.	Item	Part No.	Quantity	Description	Wt.#
08-1012				Drain Assembly	
	1A	04-10321	1	Ball Valve	6
	1B	04-1033	1	Camlock Adaptor	1.5
	1C	04-10331	1	Camlock Plug	.5
	1D	04-1034	1	Safety Chain	.2
	1E	04-1035/	1	S-Hook, Safety Link	.1
	1F	04-1035	1	S-Hook, Safety Link	.1
08-1013				Grounding Reel Assembly	
	2	04-10361	1	Grounding Reel	12
	2A	04-1036	1	Grounding Reel	12
	2B	02-10040	4	Bolts	.3
	2C	02-12041	4	Nuts	.1
08-1014	3			Sight Gauge Assembly	
	3A	03-0017S	2	Elbow	.5
	3B	03-1007	1	Tee	.5
	3C	03-1008	2	Nipple	.5
	3D	03-11130	2	Hose Barb	1
	3E	03-1010	2	Hose Clamp	.1
	3F	04-1032	1	Ball Valve	2.7
	3G	06-2527	1	Tubing	.1
	5	04-1037	1	Vent	3

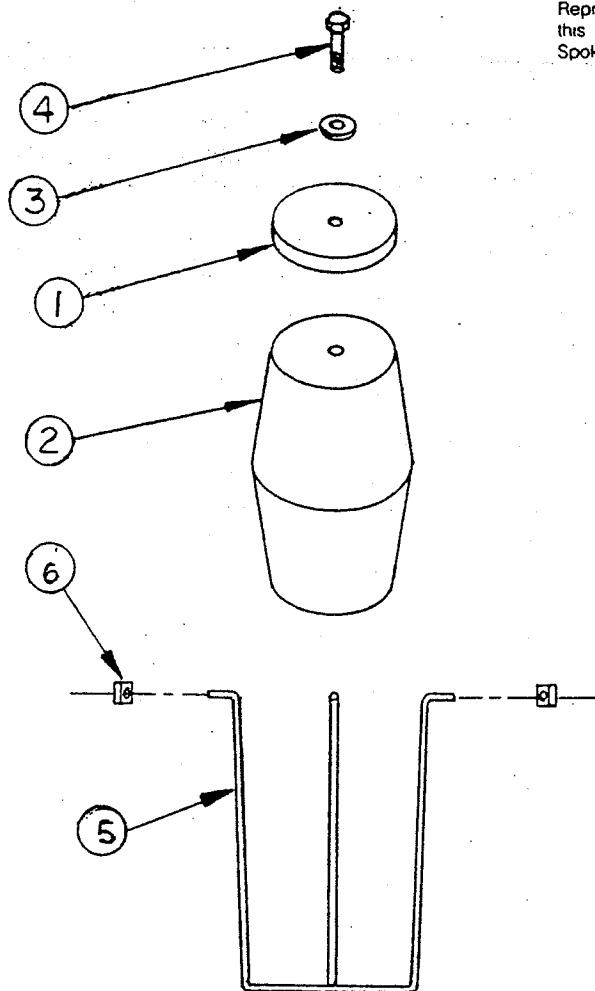

ASSEMBLY NO. 08-10011

MAJOR ASSEMBLY - VENT, OVERFLOW PREVENTOR

Sub Assy.	Item	Part No.	Quantity	Description	Wt.#
08-1022				Float Assembly	
	1	04-1047	1	Gasket	1
	2	06-1013	1	Float	.5
	3	02-1100	1	Washer	.1
	4	02-10001	1	Bolt	.1
08-1023				Cage Assembly	
	5	07-1032	2	Wire Cage	.9
	6	02-12140	4	Nut	.1

Spokane Washington

400 GALLON BOWSER FUEL DRAIN TANK

ONE YEAR LIMITED WARRANTY

Seller warrants its 400 Gallon Bowser Fuel Drain Tank to be free from defects in material and workmanship under the normal use and service for which the unit is intended if, but only if the unit has been properly operated, maintained and stored in accordance with printed directions contained in the product manual. Our obligation under this Warranty shall be limited to the repair or exchange of equipment and parts which may prove defective within one year of the date the unit is put into service but shall in no event extend beyond a date two years from the date the unit is shipped from our plant. All transportation charges on parts returned to us for replacement under this warranty must be returned pre-paid.

This warranty does not extend to damage caused by environmental factors varying from normal design conditions, whether natural or man-made, or to units subjected to misuse, negligence or accident. This warranty likewise does not extend to the unit or any parts thereof which have been repaired or altered improperly or in any way so as to effect adversely its stability or reliability. This warranty does not cover parts or labor required to repair or replace parts whose usefulness is exhausted due to normal operation of the unit.

THIS WARRANTY IS EXPRESSLY IN LIEU OF ALL OTHER WARRANTIES, EXPRESS OR IMPLIED, INCLUDING ANY IMPLIED WARRANTY OF MERCHANTABILITY OR FITNESS FOR A PARTICULAR PURPOSE NOT SET FORTH IN A WRITING SIGNED BY AN AUTHORIZED REPRESENTATIVE OR SELLER. SELLER SHALL IN NO EVENT BE LIABLE FOR ANY CONSEQUENTIAL LOSS OR DAMAGE RESULTING FROM THE USE OR LOSS OF USE OF THE UNIT.