

# **SPOKANE INDUSTRIES, INC.**

## **SPOKANE METAL PRODUCTS DIVISION**

Spokane Washington

CONFIDENTIAL PROPRIETARY INFORMATION

Reproductions of this data or the manufacturing of products from  
This data by anyone other than Spokane Industries, inc. of Spokane  
Washington is strictly prohibited without written consent.

## **UNIVERSAL DRAIN ASSEMBLY (UDA)**

### **TECHNICAL MANUAL PARTS AND OPERATION**

© COPYRIGHT 2001 By SPOKANE INDUSTRIES INC.  
ALL RIGHTS RESERVED

This document discloses subject matter in which Spokane Industries, Inc has Proprietary rights and such subject matter shall not, without the written permission of Spokane Industries, Inc., be either (A) used, released or disclosed in whole or in part outside the government, (B) used in whole or in part by the government, for manufacture, or (C) used by a party other than the government, except for (1) emergency repair or overhaul work only, by or for the government, where the item or process concerned is not otherwise reasonably available to enable timely performance of the work, provided that release of disclosure hereof outside the government shall be made subject to a prohibition against further use, release of disclosure, or (2) release to a foreign government, or for emergency repair or overhaul work by or for such government under the conditions of (1) above. This legend shall be marked on any reproduction hereof in whole or in part.

## **SECTION 18**

### **UNIVERSAL DRAIN ASSEMBLY (UDA)**

#### **INTRODUCTION:**

#### **VACUUM GENERATOR AND UNIVERSAL DRAIN ASSEMBLY (UDA)**

The use of a vacuum generator for the primary delivery of fuel into the bowser unit was based upon many optimal benefits. The generator is economical to operate, compact in size, low cost, minimal maintenance as well as built to lightweight construction with no moving parts.

To obtain optimum benefit from your vacuum system it is recommended that all personnel operating it read and understand this section prior to operating.

Upon receipt of the unit, a visual inspection should be made to determine that it is complete and has not sustained any damage during transportation.

When compressed air is forced through a double conical nozzle its velocity increases and the pressure decreases. Vacuum generators operate on this principle, which creates vacuum without a single moving part.

If the aircraft is equipped with a "POP-IT", also known as a "PENCIL" type low point drain then the fuel bowser should be able to hook up and function properly.

The vacuum lid assembly is provided with quick connects for attaching the suction fuel delivery lines.

There are (4) four ½" inch suction fuel delivery lines provided on the lid of the vacuum assembly.

If the vacuum probes do not work, you will have to find a Sumping tool adapter to enable hook up.

SECTION 18  
UNIVERSAL SUMPING ASSEMBLY

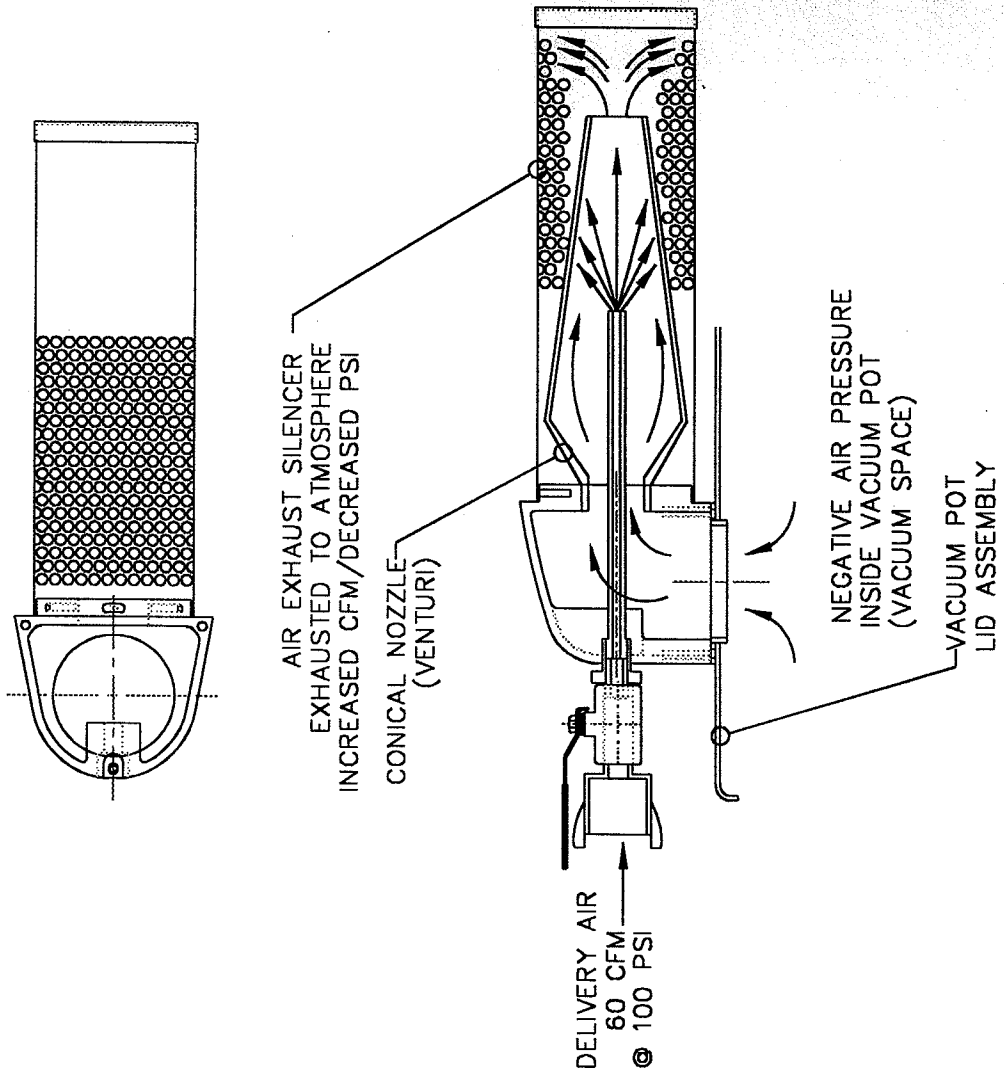

HIGH SPEED AIR PRESSURE CREATES A NEGATIVE PRESSURE INSIDE THE VACUUM POT THERE BY EVACUATING THE AIR OUT OF THE VACUUM POT AND CREATING SUCTION IN THE SUMPING CUP/ HOSE ASSEMBLY, SUCKING FUEL INTO THE VACUUM POT REPLACING THE NEGATIVE VOID.

SECTION 18  
UNIVERSAL SUMPING ASSEMBLY

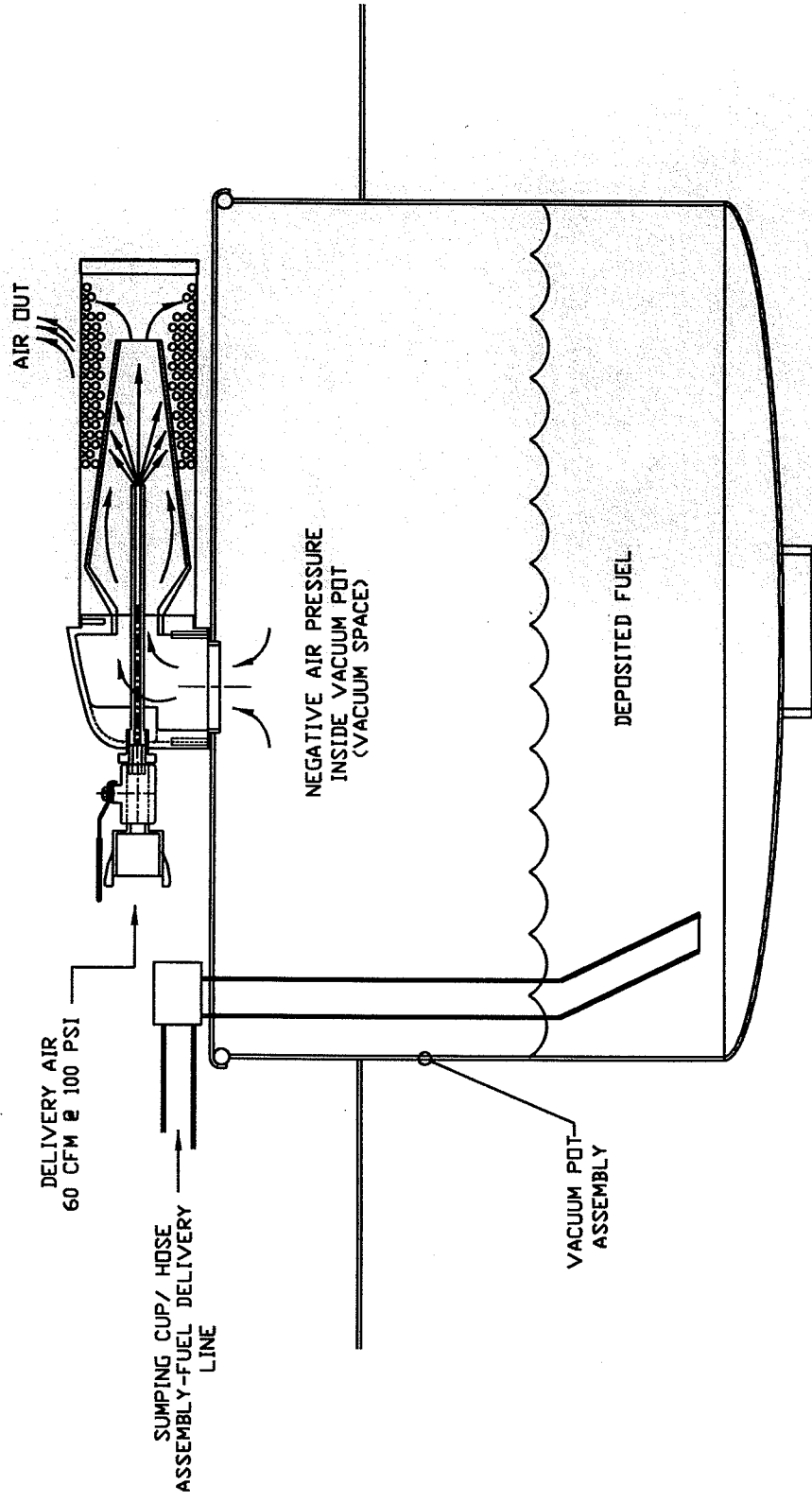

## SECTION 18

### UNIVERSAL DRAIN ASSEMBLY (UDA)

#### SAFETY

The vacuum generator is an air-operated generator. An air supply of 40 to 60 CFM @ 80 to 100 PSI is recommended to operate this system. Smaller capacity air supply will result in decreased performance.

Check the air pressure of supply lines to the vacuum generator to assure it is not in excess of 100 PSI.

Parking brake must be applied when operating the vacuum system.

The vacuum system should never be used inside of an enclosed area. Proper ventilation is required at all times.

Due to the nature of fuel, care should be exercised to eliminate all sparks and open flames in the area of the vacuum system.

To eliminate static sparks, prior to operating the vacuum system connect the grounding reels to the proper ground and to the Aircraft to be defueled.

A 50-foot radius area around the fuel bowser for no smoking, sparks or open flames is usually a good practice. It is strongly recommended all local or other regulations be consulted for further restrictions.

If other objects such as rock or metallic pieces are vacuumed into the vacuum system they may create a hazard due to sparks.

Prior to any defueling to the aircraft you must insure proper venting to the aircraft fuel tanks or fuel cells or damage to the aircraft will occur.

## SECTION 18

### UNIVERSAL DRAIN ASSEMBLY (UDA)

#### OPERATIONS

18.0 Safety Note: Review Safety Section prior to operating or maintaining (UDA).

18.1 Operation

18.1.0 Setting up the Universal Drain Assembly (UDA) with the suction fuel delivery lines to the aircraft low point pencil drains:

- 1) (Item #C4) on the drawing shows a set of probe tips with the same diameters and different lengths. The service technician will have to determine which length works best for the type of pencil drain provided with the aircraft. Thread the selected probe tip into the probe (Item # C1)  
(NOTE: If you choose a tip length too short no or little flow occurs. If you choose a tip length too long, proper sealing between (Item #B1) and the aircraft will not be achieved and the unit could fall and be damaged.)
- 2) A good clean sealing surface is required around the pencil drain for the sumping cup, (Item #B1), to vacuum seal. If the aircraft has seams or uneven surfaces an artificial mating surface may need to be considered.
- 3) There is a check valve provided, (Item #A5), on the ¼ inch clear tube line. Insure this check valve is installed, and that the direction of flow goes from (Item #B1) toward (Item #A9). This line is required for providing a vacuum area between the inner and the outer gasket seals (Items # B2 & B3) provided with the sumping cup.
- 4) Connect the female quick coupler (Item # A9) on each of the ¼ inch clear lines to the male quick couplers (Item #H2) and manifolds (Item # H1) located on the vacuum generator cover.
- 4) Connect the opposite end of the ¼ inch clear line assembly (Item #A4) to the sumping cup (Item #B1) 1/8 inch NPT port that is provided.
- 6) Connect the male quick coupler (Item E1) on each black ½ inch line x 25 Feet long, to the female quick couplers (Item # F4) located on the vacuum lid assembly.

- 7) Connect the male quick coupler (Item #D3) on each black ½ inch line x 3 feet long to the female quick coupler (Item # E2) on the black ½ inch line x 25 feet long.
- 8) Install the vacuum probe (Item #C1) into the sumping cup center (Item # B1) by inserting probe and turning 90 degrees to lock into place.
- 9) Cover the inner and outer gasket seals (Items #B2 & B3) with a light coat of petroleum jelly.
- 10) Close each of the 1/8 inch slider valves (Item #A3) located on the sumping cups where the ¼ inch clear lines attach to the sumping cups by sliding the knurled valve ring away from the sumping cup.
- 11) Connect 1/2 inch minimum air supply line to the vacuum generator inlet twist coupler making sure that both vacuum generator ball valves are in the off position. (Note: the air supply recommended is 40 to 60 CFM at 80 to 100PSI) (Note: make sure that all aircraft fuel tank or fuel cell vents are open prior to any defueling or damage to the aircraft will occur.)
- 12) Turn on the small vacuum generator (Item #J1) by opening the ¼ inch ball valve (Item #J6) located on the left side of the centered main vacuum generator on the top of the vacuum lid.
- 13) Align the vacuum probe (Item #C1) with the proper tip (Item #C4) installed to the aircraft "POP-IT" (pencil) low point drain on the wing and the fuselage low point drains.
- 14) Open the 1/8 inch slide valve (Item #A3) on the selected cup (Item #B1) to attach to aircraft by moving the knurled ring toward the sumping cup and attaching the cup/probe (Items #B1 & C3) into the low point drain making sure probe tip is centered on the low point drain.
- 15) Observe the clear ¼ inch line (Item #A4) for fuel leaking past inner seal (Item #B3). If any fuel is present in the ¼" inch line (Item #A4) remove sumping cup assembly (Item #B1) by reversing the previous directions. Re-seal or replace the seals (Items #B2 & B3) as required.
- 16) Turn on the large vacuum generator by opening the ½ inch ball valve located on the centered main vacuum generator on the top of the vacuum lid.
- 17) Slowly open up the 1/2 inch quick coupler ball valves (Item #F2) located on the vacuum lid for only the black ½ inch lines to be used, watching for leaks and seepage past the seals. Repair as required to stop any leaks.

- 18) Reinstall sumping cup if required.
- 19) Commence with defueling operation only when all observations prove a proper seal tight operation.
- 20) Once the operation has started the fuel is delivered from the aircraft to the vacuum.
- 21) **For the intermittent vacuum type units only:**  
the vacuum chamber is equipped with an automatic drain valve that opens when vacuum is eliminated in the chamber. This valve opens directly into the main tank.
- 22) The vacuum generator is equipped with a float actuated automatic overflow shutoff. When the vacuum chamber or the tank is full the float valve shuts off and eliminates the vacuum. (On the intermittent type units the vacuum chamber will then automatically drain and the air supply must be shut off to reset the overflow valve before defueling can continue.)

## 18.2 Maintenance

- 1) The vacuum generator is supplied with a filtered exhaust silencer. Remove and wash this with soap and water. Thoroughly dry and reinstall as needed.
- 2) All vacuum hoses should be inspected regularly for cracking. Any sudden loss of vacuum suction power may indicate a crack in the hose lines, replace if any cracks, deformation or any leakage is visible.
- 3) Check both inner and outer sumping cup seals prior to each usage, Replace if any cracks or deformation is visible.
- 4) Check the "O-Ring" Seal on the probe prior to each usage replace if any cracks or deformation is visible.
- 5) Check probe tips to ensure that they are not bent or damaged, replace as required.
- 6) Check all components regularly

**Section 18.0**

**Assembly Part No. 08-14000**

**Universal Drain Assembly (UDA)**

Item No.	PART #	QTY.	DESCRIPTION
<b>08-14001</b>	<b>Assembly</b>	<b>4</b>	<b>Sumping Cup assembly, consisting of :</b>
A1	03-111334	1	HOSE BARB, BRASS 1/8 NPT x 1/4" Barb #29-42
A2	03-10105	2	CLAMP, OITKER 1/2 #11/13
A3	04-10325	1	Slider valve, 1/8" Brass, #250
A4	06-2526	1	TUBING, 1/4 X 1/2 OD PVC X 25'-0" #510
A5	04-10099	1	CHECK VALVE, BRASS, LINDE #639110
A6	03-111336	1	HOSE BARB ADAPTOR, BRASS, LINDE #17
A7	03-111337	1	NUT, BRASS, LINDE #7
A8	03-111338	1	BUSHING, BRASS, LINDE #32
A9	03-111398	1	QUICK DISCONNECT 1/4 FEMALE #BH2-60
<b>08-0200</b>	<b>Sub-Assembl</b>	<b>1</b>	<b>Sumping cup sub-assembly consisting of:</b>
B1	05-1040	1	SUMPING CUP, MACHINED ALUMINUM
B2	06-0075	1	Seal, 4.75" OD, Viton (40 Dur), 3/16 X 1/2 (R/S 06-0072)
B3	06-0074	1	Seal, 2" ID, Viton (40 Dur), 3/16 X 1/2 (R/S 06-0072)
B4	06-00688	1	O-Ring Part No. 430-B, 5-5/8" OD, 5-1/8" ID
<b>08-14006</b>	<b>Assembly</b>	<b>4</b>	<b>3foot pigtail/probe, consisting of :</b>
<b>08-0100</b>	<b>Sub-Assembl</b>	<b>1</b>	<b>Vacuum fuel probe sub-assembly , consisting of:</b>
C1	05-1037	1	PROBE, MACHINED ALUMINUM
C2	02-1350	2	Roll Pin, .3/32" OD x 1/4" LG. #92373A139 18-8 SS
C3	06-00684	1	O-RING PART NO. 2- 214
C4	01-9187S	5	Probe pins, 8-32 thread /.204/.366/.616/.866/1.50 Lg SS
<b>08-0150</b>	<b>Sub-Assembl</b>	<b>1</b>	<b>Hose, probe pigtail sub-assembly, consisting of:</b>
D1	03-10155	1	BUSHING, BRASS, 3/4 TO 1/2 #3220 X 12 X 8
D2	06-10166	1	Aircraft Defueling hose, 1/2" x 3'Lg w/ 1/2" M-NPT ends
D3	03-111395	1	QUICK DISCONNECT, 1/2 MALE, #BH4-61
<b>08-14003</b>	<b>Assembly</b>	<b>4</b>	<b>25 foot hose assembly, consisting of :</b>
E1	03-111395	1	QUICK DISCONNECT 1/2 MALE, #BH4-61
E2	03-111394	1	QUICK DISCONNECT 1/2 FEMALE, #BH4-60
E3	06-10166	1	Aircraft Defueling hose, 1/2" x 25'Lg w/ 1/2" M-NPT ends

Continued

**Section 18.0****Assembly Part No. 08-14000****Universal Drain Assembly (UDA)**

Item No.	PART #	QTY.	DESCRIPTION
<b>08-14004</b>	<b>Assembly</b>	<b>1</b>	<b>Sumping probe adaptors, consisting of :</b>
F1	03-1006	4	Elbow, Brass street, 1/2 #3400-8
F2	04-2507	4	VALVE,BRASS, 1/2 APOLLO BALL #70-103-01
F3	03-10081	4	CLOSE NIPPLE,BRASS, 1/2 #3326-8
F4	03-111394	4	QUICK DISCONNECT, 1/2 FEMALE, #BH4-60
F5	07-1075	2	SUMPING HOSE SUPPORT BRACKET
F6	02-100115	6	BOLTS, 3/8" NC 1" LG.T-304SS
F7	02-1202	6	NUTS. 3/8" NC NYLOC, T-304SS
<b>08-14002</b>	<b>Assembly</b>	<b>1</b>	<b>Vacuum Mainfold Assembly, consisting of:</b>
H1	05-1046	2	Vacuum manifold blocks, Machined Aluminum
H2	03-111397	4	QUICK DISCONNECT, 1/4 MALE #BH2-61
H3	03-10252	2	PLUG, BRASS, 1/4 NPT #3151-4
H4	03-10015	2	PLUG, BRASS, 1/8 NPT #3151-2
H5	02-10015	4	BOLT, HEX, 5/16 X 1-3/4 LG. T-304 SS
H6	02-12012	4	NUT, 5/16 T-304 SS
<b>08-14005</b>	<b>Assembly</b>	<b>1</b>	<b>Vacuum pump Assembly, consisting of:</b>
J1	04-100035	1	Vacuum Pump, 1/8" Intake/1/4" Outlet, #41605K14
J2	03-10058	2	Tee, 1/2" Brass #3700-8
J3	03-11135	2	Bushing, 1/2" x 1/4" Brass #3220-8-4
J4	03-10692	1	Nipple, 1/4" x 1.5" lg Brass # 3327-4
J5	03-11136	1	Street El, 1/4" x 90 #3400-4
J6	04-2506	1	Valve, Ball, 1/4" Brass #70-101-01
J7	03-11133	1	HOSE BARB, BRASS 1/4 NPT x 1/4" Barb #29-44
J8	06-2526	1	TUBING, 1/4 X 1/2 OD PVC X 12" #510
J9	03-10105	2	CLAMP, OITKER 1/2 #11/13
J10	03-111334	1	HOSE BARB, BRASS 1/8 NPT x 1/4" Barb #29-42
J11	03-10690	1	CLOSE NIPPLE,BRASS,1/4 #3325-4
J12	06-10166	1	Aircraft Defueling hose,1/2" x 22" Lg w/ 1/2"M-NPT ends
J13	06-10166	1	Aircraft Defueling hose,1/2" x 24" Lg w/ 1/2"M-NPT ends
J14	01-8425	1	Shim Block, 1/2" x 1-1/4" x 3" Aluminum
J15	02-1510	2	Slotted Head Capscrew, #10-32 x 1-3/4" SS
J16	01-1210	2	Hex Nut, #10-32 SS
J17	03-10081	1	CLOSE NIPPLE,BRASS, 1/2 #3326-8

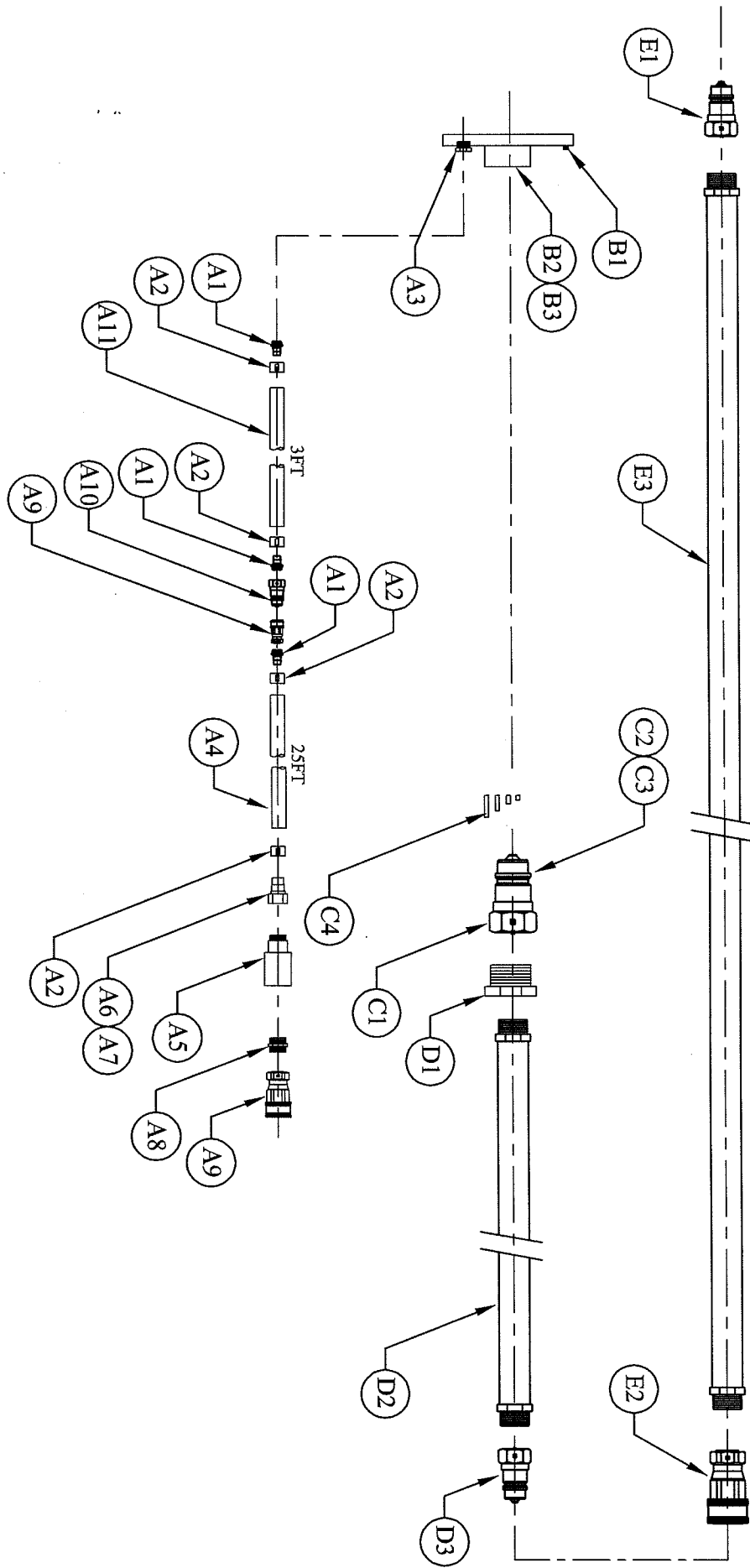

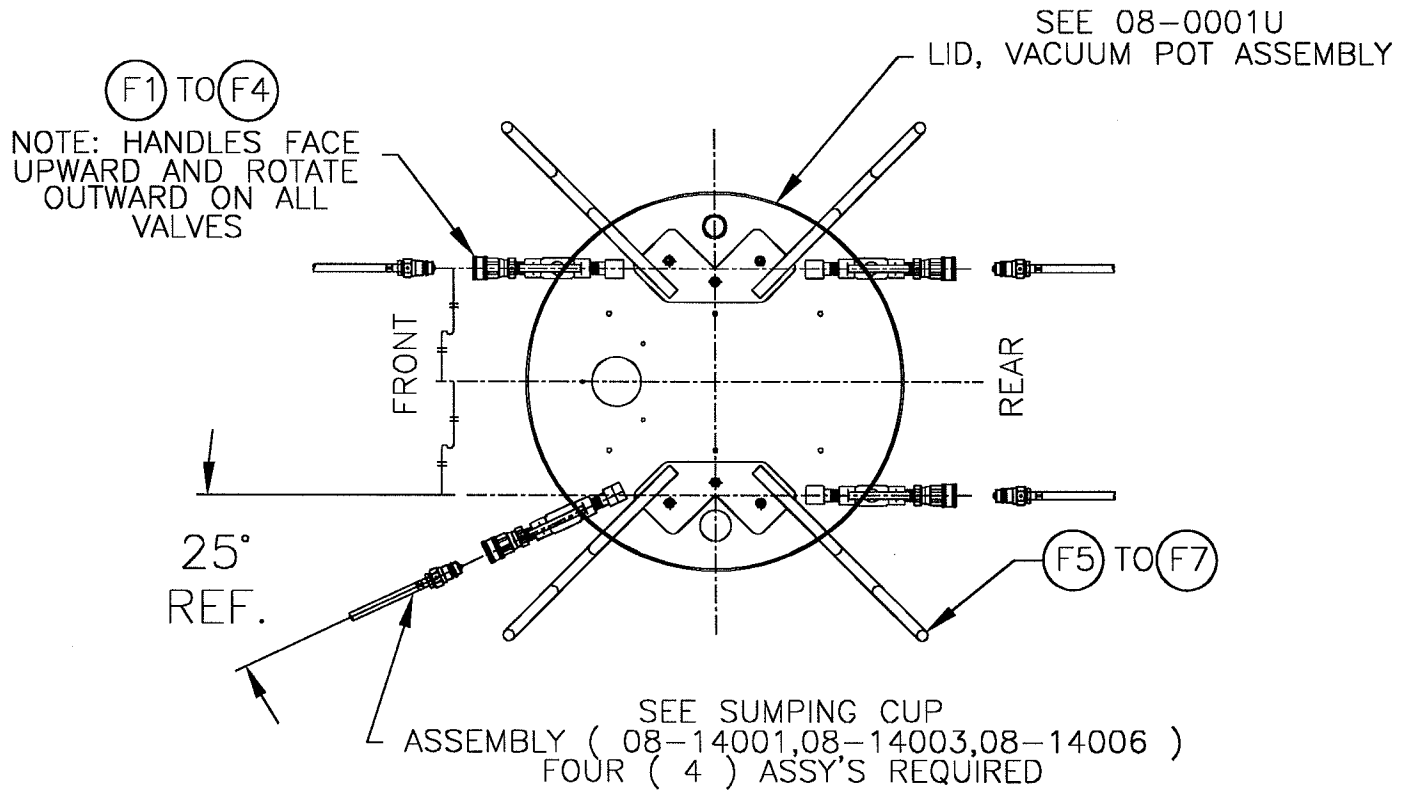

TOP ASSEMBLY VIEW

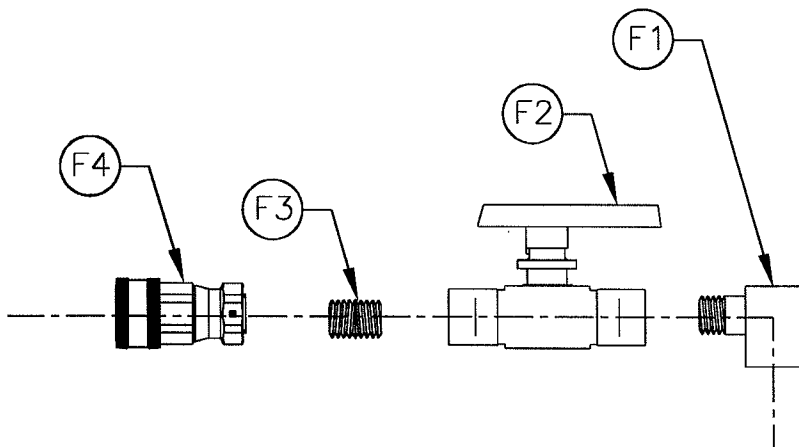

VALVE ASSEMBLY

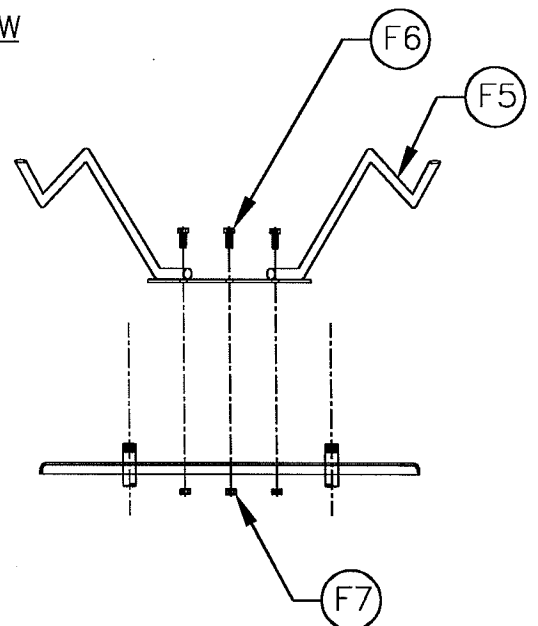

HOSE HANGER SUPPORT BRACKET

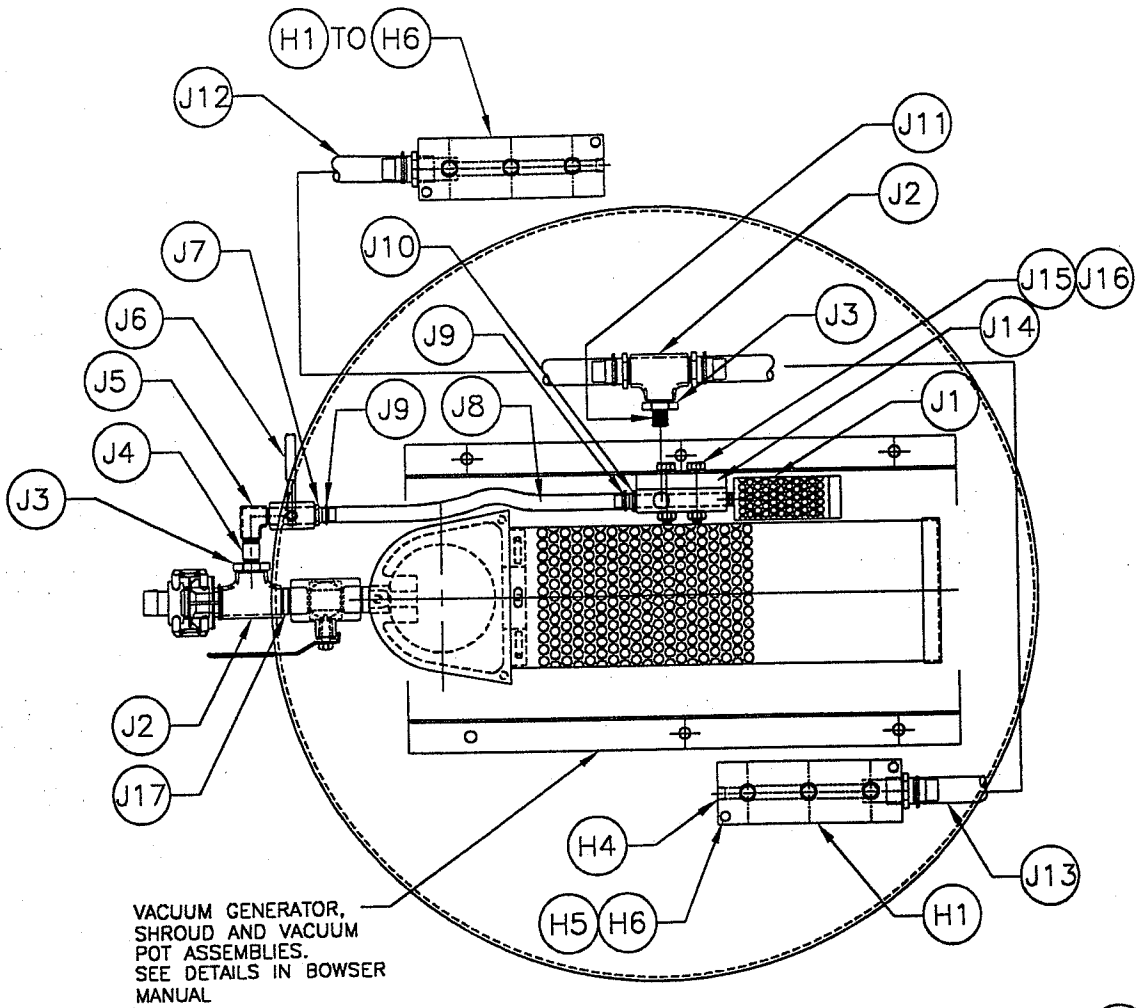

TOP VIEW ASSEMBLY DETAILS

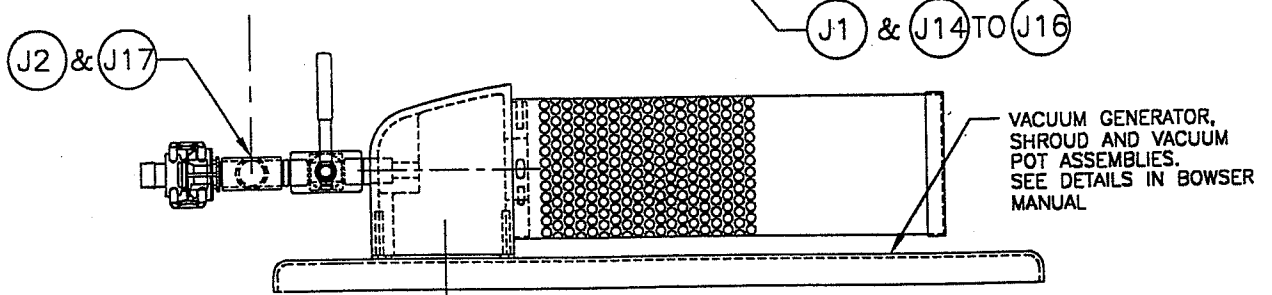
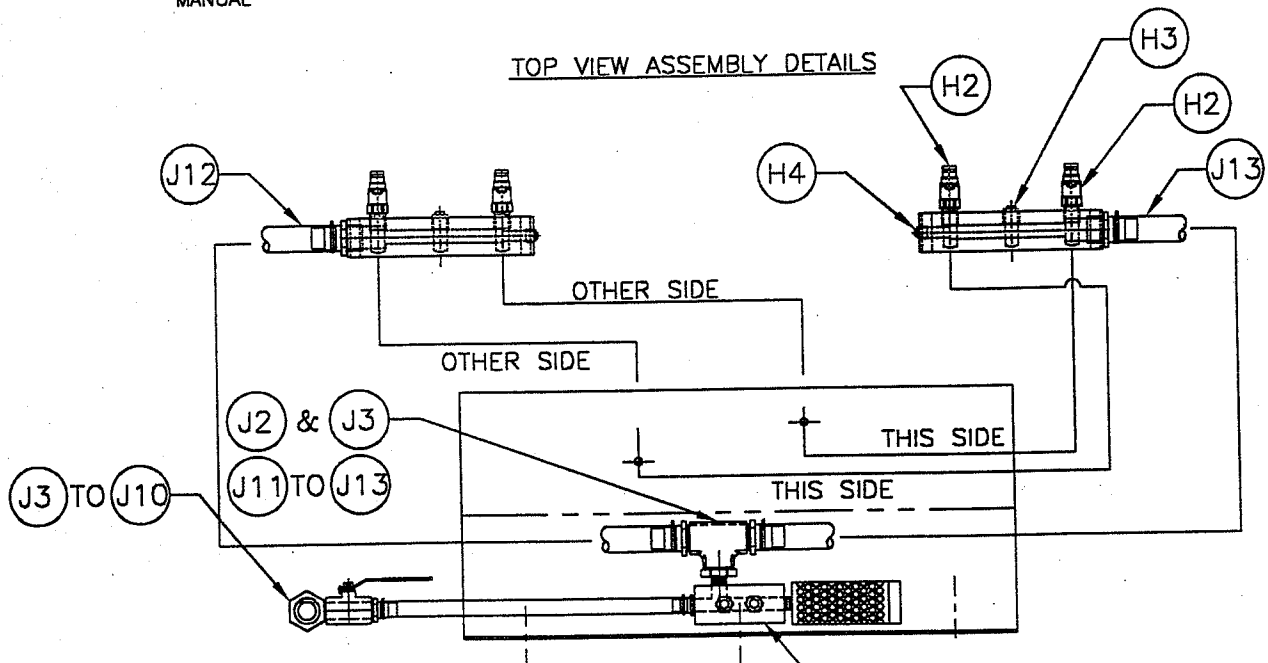

SIDE VIEW ASSEMBLY DETAILS

# **SPOKANE INDUSTRIES, INC.**

**SPOKANE METAL PRODUCTS DIVISION**

Spokane Washington

## **VACUUM GENERATOR AND UNIVERSAL SUMPING CUP ASSEMBLY ONE YEAR LIMITED WARRANTY**

Seller warrants its "Vacuum Generator and Universal Sumping Cup Assembly" to be free from defects in material and workmanship under the normal use and service for which the unit is intended if, but only if the unit has been properly operated, maintained and stored in accordance with printed directions contained in the product manual. Our obligation under this warranty shall be limited to the repair or exchange of equipment and parts which may prove defective within one year of the date the unit is put into service but shall in no event extend beyond a date two years from the date the unit is shipped from our plant. All transportation charges on parts returned to us for replacement under this warranty must be returned pre-paid.

This warranty does not extend to damages caused by environmental factors varying from normal design conditions, whether natural or man-made, or to units subjected to misuse, negligence or accident. This warranty likewise does not extend to the unit or any parts thereof which have been repaired or altered improperly or in any way so as to effect adversely its stability or reliability. This warranty does not cover parts or labor required to repair or replace parts whose usefulness is exhausted due to normal operation of this unit.

**THIS WARRANTY IS EXPRESSLY IN LIEU OF ALL OTHER WARRANTIES, EXPRESS OR IMPLIED, INCLUDING ANY IMPLIED WARRANTY OF MERCHANTABILITY OR FITNESS FOR A PARTICULAR PURPOSE NOT SET FORTH IN A WRITING SIGNED BY AN AUTHORIZED REPRESENTATIVE OR SELLER. SELLER SHALL IN NO EVENT BE LIABLE FOR ANY CONSEQUENTIAL LOSS OR DAMAGE RESULTING FROM THE USE OR LOSS OF USE OF THIS UNIT.**

OBSOLETE

PRIOR TO  
11/03

000  
(UDA)

consisting of :  
NPT x 1/4" Barb #29-42  
/13  
50  
7C X 25'-0" #510

A5	04-10099	1	CHECK VALVE, BRASS, LINDE #639110
A6	03-111336	1	HOSE BARB ADAPTOR, BRASS, LINDE #17
A7	03-111337	1	NUT, BRASS, LINDE #7
A8	03-111338	1	BUSHING, BRASS, LINDE #32
A9	03-111398	1	QUICK DISCONNECT 1/4 FEMALE #BH2-60
<b>08-0200</b>	<b>Sub-Assembl</b>	<b>1</b>	<b>Sumping cup sub-assembly consisting of:</b>
B1	05-1040	1	SUMPING CUP, MACHINED ALUMINUM
B2	06-0075	1	Seal, 4.75" OD, Viton (40 Dur), 3/16 X 1/2 (R/S 06-0072)
B3	06-0074	1	Seal, 2" ID, Viton (40 Dur), 3/16 X 1/2 (R/S 06-0072)
<b>08-14006</b>	<b>Assembly</b>	<b>4</b>	<b>3foot pigtail/probe, consisting of :</b>
<b>08-0100</b>	<b>Sub-Assembl</b>	<b>1</b>	<b>Vacuum fuel probe sub-assembly , consisting of:</b>
C1	05-1037	1	PROBE, MACHINED ALUMINUM
C2	02-1350	2	Roll Pin, .3/32" OD x 1/4" LG. #92373A139 18-8 SS
C3	06-00684	1	O-RING PART NO. 2- 214
C4	01-9187S	5	Probe pins, 8-32 thread / .204/.366/.616/.866/1.25 Lg SS
<b>08-0150</b>	<b>Sub-Assembl</b>	<b>1</b>	<b>Hose,probe pigtail sub-assembly, consisting of:</b>
D1	03-10155	1	BUSHING, BRASS, 3/4 TO 1/2 #3220 X 12 X 8
D2	06-10166	1	Aircraft Defueling hose, 1/2" x 3'Lg w/ 1/2" M-NPT ends
D3	03-111395	1	QUICK DISCONNECT, 1/2 MALE, #BH4-61
<b>08-14003</b>	<b>Assembly</b>	<b>4</b>	<b>25 foot hose assembly, consisting of :</b>
E1	03-111395	1	QUICK DISCONNECT 1/2 MALE, #BH4-61
E2	03-111394	1	QUICK DISCONNECT 1/2 FEMALE, #BH4-60
E3	06-10166	1	Aircraft Defueling hose, 1/2" x 25'Lg w/ 1/2" M-NPT ends

