

# **SPOKANE INDUSTRIES, INC.**

**SPOKANE METAL PRODUCTS DIVISION**  
Spokane Washington

CONFIDENTIAL PROPRIETARY INFORMATION  
Reproductions of this data or the manufacturing of products from  
This data by anyone other than Spokane Industries, inc. of Spokane  
Washington is strictly prohibited without written consent.

**UNITED AIR LINES**  
**DOUBLE WALL/400 GALLON**  
**FUEL BOWSER**  
**TECHNICAL MANUAL**  
**PARTS, OPERATION AND MAINTENANCE**  
**MODEL NUMBER: UAL 400 BOW**

© COPYRIGHT 2000 By SPOKANE INDUSTRIES INC.  
ALL RIGHTS RESERVED

This document discloses subject matter in which Spokane Industries, Inc has Proprietary rights and such subject matter shall not, without the written permission of Spokane Industries, Inc., be either (A) used, released or disclosed in whole or in part outside the government, (B) used in whole or in part by the government, for manufacture, or (C) used by a party other than the government, except for (1) emergency repair or overhaul work only, by or for the government, where the item or process concerned is not otherwise reasonably available to enable timely performance of the work, provided that release of disclosure hereof outside the government shall be made subject to a prohibition against further use, release of disclosure, or (2) release to a foreign government, or for emergency repair or overhaul work by or for such government under the conditions of (1) above. This legend shall be marked on any reproduction hereof in whole or in part.

Spokane Industries, Inc.  
Spokane Metal Products Division  
P.O. Box 3303  
Spokane, WA 99220-3303  
Telephone: (509) 928-0720  
Tele Fax: (509) 927-0826  
Email: [dyorke@spokaneindustries.com](mailto:dyorke@spokaneindustries.com)

# 400 GALLON FUEL BOWSER

## TECHNICAL MANUAL PARTS, OPERATION AND MAINTENANCE MODEL NUMBER UAL 400 BOW

### INDEX

		<u>PAGE</u>
<u>Section 1.</u>	Introduction .....	1
<u>Section 2</u>	Safety .....	1
<u>Section 3</u>	Operation	
	3.1 Intended Use .....	3
	3.2 Tow Bar and Under Carriage .....	3
	3.3 Tow Bar Actuated Parking Brake .....	3
	3.4 20" Manway .....	3
	3.5 Grounding .....	3
	3.6 Drain Valve .....	4
	3.7 Telescoping Drain Assembly .....	4
	3.8 Telescoping Drain Sump .....	4
	3.9 Vacuum Assembly .....	5
	3.10 Vent Overflow Preventer .....	5
<u>Section 4</u>	Maintenance	
	4.1 Tow Bar and Under Carriage .....	6
	4.2 Tow Bar Actuated Parking Brake .....	6
	4.3 20" Manway .....	7
	4.4 Sight Gauge Assembly .....	7
	4.5 Grounding.....	7
	4.6 Telescoping Drain Assembly .....	7
	4.7 Telescoping Drain Sump .....	7
	4.8 Vacuum Assembly .....	8
	4.9 Vent Overflow Preventer .....	8
	4.10 Fire Extinguisher .....	8
	4.11 Trouble Shooting .....	9

## INDEX

<u>Section 5</u>	Replacement Parts .....	9
	Assembly Tank .....	10
5.1	Main Tank .....	11
5.2.1	Front Axle Assembly .....	12
5.2.2	Rear Axle Assembly .....	14
5.2.3	Tow Bar Actuated Parking Brake Assembly .....	15
5.2.4	Front Wheel Assembly .....	19
5.2.5	Rear Wheel Assembly .....	22
5.3	20" Manway Assembly .....	25
5.4	Decal Package .....	26
5.5	Telescoping Drain Assembly .....	27
5.5.1	Telescoping Drain Sump Assembly .....	29
5.6	Vacuum Assembly .....	30
5.7	Miscellaneous Fixtures .....	33
5.8	Vent Overflow Preventer .....	35
5.9	Fire Extinguisher .....	36
5.10	Tool Box .....	37
5.11	Remote Drain Funnel Assembly .....	38
<u>Warranty</u>	.....	39

## 1.0 Introduction

- 1.1 To obtain optimum benefit from your fuel bowser unit, it is recommended that all personnel operating it read and understand this manual prior to operation.
- 1.2 Upon receipt of the bower unit, a visual inspection should be made to determine that it is complete and has not sustained any damage during transportation.

## 2.0 Safety

### 2.1 Potential Fire and Explosion

- 2.1.1 Due to the nature of fuel, care should be exercised to eliminate all sparks and open flame in the area of the bowser unit.
- 2.1.2 A 50-foot radius area around the bowser unit for no smoking, sparks or open flames is usually a good practice. It is strongly recommended all local or other regulations be consulted for further restrictions.

**CAUTION:** The fuel bowser should never be used inside of an enclosed area. Proper ventilation is required at all times.

### 2.2 Telescoping Drain

- 2.2.1 Care should be exercised in using the telescoping assembly to prevent injuring fingers between clamps by dropping sections.

### 2.3 Grounding

- 2.3.1 To eliminate static sparks; the fuel bowser unit is equipped with two (2)-grounding reels. Connect prior to draining or filling operations as described in the "Operations Section".

### 2.4 Towing

- 2.4.1 Make sure the tow bar is securely attached to the towing vehicle.
- 2.4.2 Maximum allowable towing speed is 15 MPH.

### 2.5 Tow Bar Actuated Parking Brake

- 2.5.1 Parking brake must be applied when filling and draining or when left unattended.

### 2.6 Air Supply

- 2.6.1 **CAUTION:** Check the air pressure of supply lines to the vacuum generator to assure it is not in excess of 100 PSI.

## 2.0 Safety (Continued)

### 2.7 Inspections

- 2.7.1 Inspections of tires, undercarriage, tow bar, vent, valves, hoses, sight gauge, reflectors, safety labels, etc., should be inspected on a periodic basis. It is recommended these inspections be performed weekly.
- 2.7.2 Internal inspection will be necessary to insure structural integrity and cleanliness. It is recommended that interval inspections be performed at least every six- (6) months.

**CAUTION:** When entering confined spaces such as the interior of the bowser tank, care should be taken to provide proper breathing equipment and a separate person dedicated solely to a safety watch of the person inside. It is strongly recommended that all local or other regulations be consulted.

### 2.8 20" Manway

- 2.8.1 Insure the manway cover is provided with a "lock out" devised to prevent accidental closing of the manway while doing internal inspections and to prevent unwanted elements from being introduced to the fuel supply.

### 2.9 Hoses

- 2.9.1 Inspect hoses daily prior to usage. The hoses should be extended, as it normally would be for operating. Check for evidence of blistering, carcass saturation or separation, cuts, nicks or abrasions that expose reinforcement materials. Look for slippage, misalignments or leaks at the couplings; if coupling slippage or leaks are found the cause of the problem shall be determined. All defective hoses should be removed from service.

### 2.10 Fire Extinguisher

- 2.10.1 Mounted on each side of the bowser is one 20-lb. Purple K fire extinguisher meeting U/L 30B:C and NFPA 407 specifications.
- 2.10.2 Inspect the fire extinguisher before each use of the fuel bowser. Insure fill condition is fully charged and no visible damages are evident.
- 2.10.3 If damages or charging is required follow manufacturer recommendations or replace as needed.

### 3.0 Operations

- 3.1 Intended Use
  - 3.1.1 The fuel bowser unit is intended for use in draining and collection of fuel from aircraft or storage area and then transportation to the storage area or disposal site. Any other use is prohibited and may void any and all warranties.
  
- 3.2 Tow Bar and Undercarriage
  - 3.2.1 The fuel bowser unit is equipped with steering front wheels controlled by the tow bar.
  - 3.2.2 Care should be taken not to jackknife the bowser when backing up.
  - 3.2.3 Tire inflation should be checked and maintained as described in the "Maintenance Section".
  - 3.2.4 Before towing, check to see that the grounding reel, air lines and hoses are disconnected, and valves are closed, tow bar is securely attached to the towing vehicle and all manway and covers are closed and latched.
  - 3.2.5 The fuel bowser unit is equipped with a tow bar latch to hold it in the upright position.
  
- 3.3 Tow Bar Actuated Parking Brake
  - 3.3.1 The fuel bowser unit is equipped with a mechanical lever operated parking brake. The brake is applied when the tow bar is in the upright vertical position. The brake should be applied when filling, draining tank or whenever the bowser is left unattended.
  
- 3.4 20" Manway
  - 3.4.1 The fuel bowser unit is equipped with a 20" quick opening manway assembly for internal inspections.
  - 3.4.2 The manway is equipped with a flip locking cross arm assembly to ensure sealing and securing the cover lid in place.
  
- 3.5 Grounding
  - 3.5.1 The fuel bowser unit is supplied with two (2)-grounding reels.

### 3.0 Operations (continued)

#### 3.5 Grounding (Continued)

- 3.5.2 Before filling or draining, the grounding reels must be attached between the aircraft or object being serviced and an appropriate ground.

#### 3.6 Drain Valve

- 3.6.1 The fuel bowser unit is equipped with a 1-1/2" NPT ball valve with a cam lock connector.

### 3.7

#### Telescoping Drain Assembly

- 3.7.1 The fuel bowser is equipped with a telescoping drain assembly. It is capable of being adjusted to 16ft-0in high.
- 3.7.2 To Raise:
- (1) Loosen top clamp if necessary.
  - (2) Grasp top section with one hand and lift as required.
  - (3) Tighten clamp securely with the other hand.
  - (4) Reposition lifting hand by grasping tube below tightened clamp and lift as required.
  - (5) Repeat steps 1-4 until desired height is obtained or assembly is fully extended.
- 3.7.3 To Lower:
- (1) Tightly grasp bottom extended tube, with one hand loosen the securing clamp.
  - (2) Slowly lower tube hand over hand, until the following clamp is resting on the loosened clamp.
  - (3) Repeat steps 1 and 2 until all sections are lowered.
- 3.7.4 Funnel is equipped with a nitrile rubber seal around the top edge to allow placement against the underside of the wing.
- 3.7.5 When not in use, telescoping funnel should be collapsed and the cover closed to eliminate contamination.

#### 3.8 Telescoping Drain Sump

- 3.8.1 The fuel bowser unit is equipped with a sump with a removable bottom to allow service and cleaning.

### 3.0 Operations (Continued)

#### 3.9 Vacuum Assembly

- 3.9.1 This assembly is equipped with an air powered vacuum generator.
- 3.9.2 It is intended for vacuum draining or depuddling fuel and condensation. Caution! If other objects such as rock or metallic pieces are vacuumed into the vacuum chamber, they may create a hazard due to sparking.
- 3.9.3 Vacuum is started by attaching a recommended air supply of 60 CFM at 100 PSI and turning on the air supply valve.
- 3.9.4 The vacuum assembly is supplied with 50 feet of vacuum hose and a ball valve on the vacuum suction outlet.
- 3.9.5 The vacuum assembly is equipped with (4) four each ½" NPT opening for use with pencil drains. To use, the pipe caps must be removed and self-closing quick disconnects attached that match local standards. To operate, close vacuum suction valve and turn air supply on and connect drain lines.
- 3.9.6 The vacuum chamber is equipped with an automatic drain valve that opens whenever vacuum is eliminated in the chamber. This valve opens directly into the main tank.
- 3.9.7 The vacuum generator is equipped with an automatic overflow protector. When the level of product reach full, the valve shuts off and eliminates the vacuum. The vacuum chamber will then automatically drain. The air supply must be shut off to reset the overflow valve. Vacuum may then continue.

#### 3.10 Vent Overflow Protector

- 3.10.1 The bowser unit is equipped with a float-actuated seal to prevent fuel from flowing out the vent in the event the bowser is overfilled.

## 4.0 Maintenance

### 4.1 Tow Bar and Under Carriage

- 4.1.1 The fuel bowser unit is equipped with steering front wheels, controlled by the tow bar and fixed rear wheels.
- 4.1.2 Maintenance should consist of the following:
  - 1) Kingpin bushing, turning bushings and tie rod ends are self-lubricating and need no additional maintenance.
  - 2) Inspect wheel bearings at three (3) month intervals. Repack and/ or replace as needed.
  - 3) Check tire pressure weekly. Maintain pressure as per tire markings.
- 4.1.3 Tow bar pivot pin and hook ring should be inspected monthly for excessive wear or cracks.

### 4.2 Tow Bar Actuated Parking Brake

- 4.2.1 The fuel bowser unit is equipped with a parking brake assembly consisting of a 7" diameter brake drum with 1 ¾" wide brake shoes.
- 4.2.2 The shoes are activated via a mechanical linkage, eccentric and lever.
- 4.2.3 The brakes are applied when the tow bar is in the upright vertical condition. The brakes release when the tow bar is lowered via mechanical spring return.
- 4.2.3 Adjustment may be necessary as the shoes wear.
  - 1) Tightening is accomplished by removing the bolt through one yoke and screwing the yoke to shorten/ lengthen the connecting rod as required.
  - 2) Do not over tighten or brakes may drag when released.
- 4.2.4 Brake Shoe Replacement
  - 1) Remove wheel.
  - 2) Remove nut retaining hub and drum assembly.
  - 3) Disconnect actuating rod.
  - 4) Remove shoe retainers.
  - 5) Install new shoes.
  - 6) Replace shoe retainers.
  - 7) Adjust actuator rod length.
  - 8) Replace wheel.

## 4.0 Maintenance (continued)

- 4.3 20" Manway
  - 4.3.1 Inspect manway gasket weekly for cuts, cracks or galling. Replace as needed.
  
- 4.4 Sight Gauge Assembly
  - 4.4.1 The sight gauge should be inspected monthly for loose connections and weathering of clear tubing. Replace as required.
  
- 4.5 Grounding
  - 4.5.1 Grounding reel cables should be pulled out, cleaned and inspected monthly.
  
  - 4.5.2 Cable clamps and ends should be inspected for loose connections monthly.
  
- 4.6 Telescoping Drain Assembly
  - 4.6.1 The telescoping drain assembly consists of a 4 ½" stainless steel housing permanently attached to the tank and (5) five aluminum tube sections.
  
  - 4.6.2 The stainless tube and four (4) largest aluminum sections are equipped with a clamp assembly.
  
  - 4.6.3 Each aluminum section is crimped on the lower end of the tubing, which acts as a stop to prevent the tube from sliding through the clamp.
  
  - 4.6.4 Disassembling of the funnel sections are accomplished by rotating the three (3) sections 180 degrees from normal position and gently lifting each section so that the crimped edge on the tube is aliend with the slot on the clamp.
  
- 4.7 Telescoping Drain Sump
  - 4.7.1 The fuel bowser is provided with a sump assembly located directly under the telescoping assembly.
  
  - 4.7.2 Drain the bowser and the sump prior to service and inspection.
  
  - 4.7.3 Maintenance should consist of inspection and cleaning monthly.

## 4.0 Maintenance (Continued)

### 4.8 Vacuum Assembly

- 4.8.1 The vacuum assembly consists of a vacuum chamber with an air powered vacuum generator mounted on a removable cover. The cover is held in place by three (3) latches.
- 4.8.2 The vacuum cover is equipped with an overflow valve which should require no maintenance.
- 4.8.3 The vacuum generator is attached to the chamber cover. The generator is equipped with an exhaust silencer which should be cleaned at six (6) month intervals or more often depending on the amount of use and conditions.
- 4.8.4 The vacuum hose should be inspected monthly for cracks. Any sudden loss of vacuum suction power may indicate a crack in the vacuum hose.
- 4.8.5 The cover gasket should be inspected monthly for deterioration. This gasket should be pliable and free from weather checking.
- 4.8.6 The overflow stop pivot bolt should not be over tightened. Over tightening will restrict motion of the float.

### 4.9 Vent Overflow Preventer

- 4.9.1 The Vent Overflow Preventer is located inside the tank directly under the vent.
- 4.9.2 It consists of a caged float with an elastomer seal.

### 4.10 Fire Extinguisher

- 4.10.1 Recharge in accordance with local codes and manufacture recommendations.

## 4.12 Trouble Shooting

### Trouble Shooting

<u>SYMPTOM</u>	<u>PROBABLE CAUSE</u>	<u>PROBABLE CORRECTIONS</u>
Bowser does not track or steer	Bent king pin housing	Replace king pin housing see section 5.2.1 Item #7
	Defective tie rod end	Replace tie rod end See section 5.2.1 Item #12
	Loose or worn out bushings	Replace as needed see section 5.2.1 item #11 #16 or #18
Tow bar does not stay in the up-right position	Broken or stretched spring	Replace as needed see section 5.2.1 item #26
Parking brake does not work	Need adjustment or repairing	Adjust or replace as per instructions. See section 4.2 and 5.2.3-B

## 5.0 Replacement Parts

This section provides information for identification of parts for ordering. To Order, it is important to have the Model Number, Subassembly Number, Part Number and Description. Parts may be ordered by calling or writing to:

Spokane Industries, Inc.  
 Spokane Metal Products Division  
 P.O. Box 3303  
 Spokane, WA 99220-3303  
 Telephone: (509) 928-0720  
 Tele Fax: (509) 927-0826  
 Email: [dyorke@spokaneindustries.com](mailto:dyorke@spokaneindustries.com)

CONFIDENTIAL-PROPRIETARY INFORMATION  
 REPRODUCTION OF THESE DRAWINGS OR THE  
 MANUFACTURING OF PRODUCTS FROM THESE  
 DRAWINGS FOR USE BY ANYONE OTHER THAN  
 SPOKANE INDUSTRIES INC. OF SPOKANE, WA  
 IS STRICTLY PROHIBITED WITHOUT WRITTEN  
 CONSENT

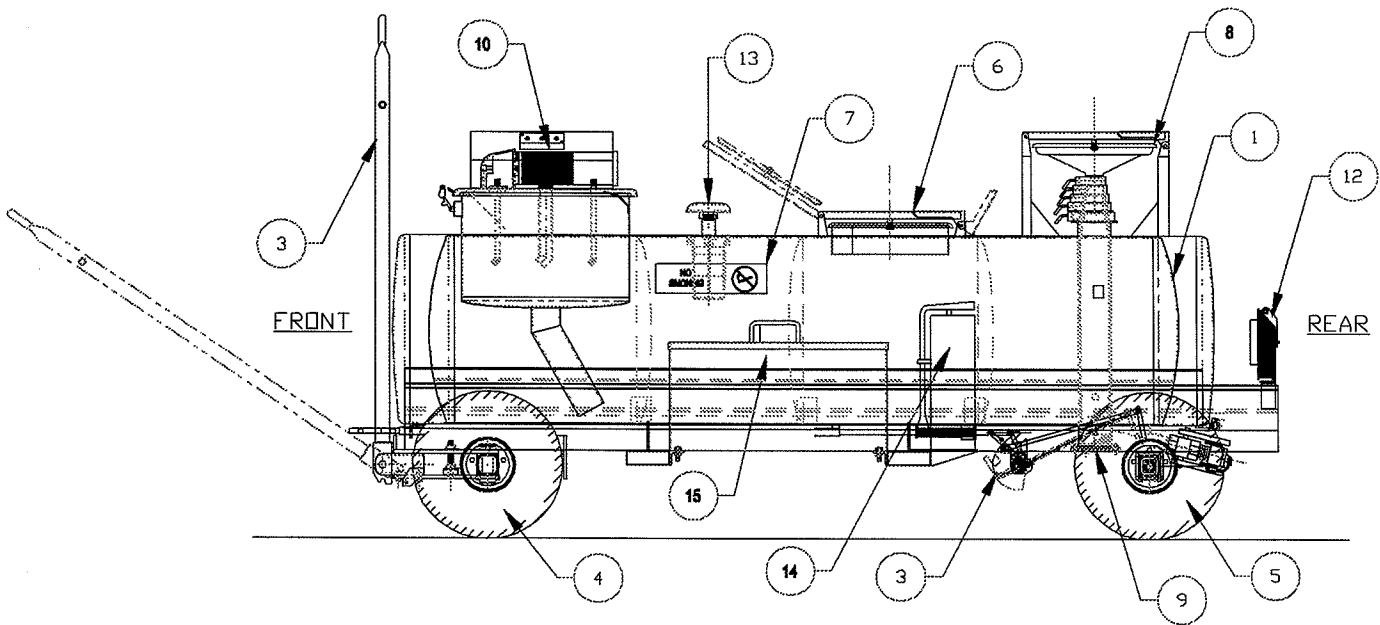
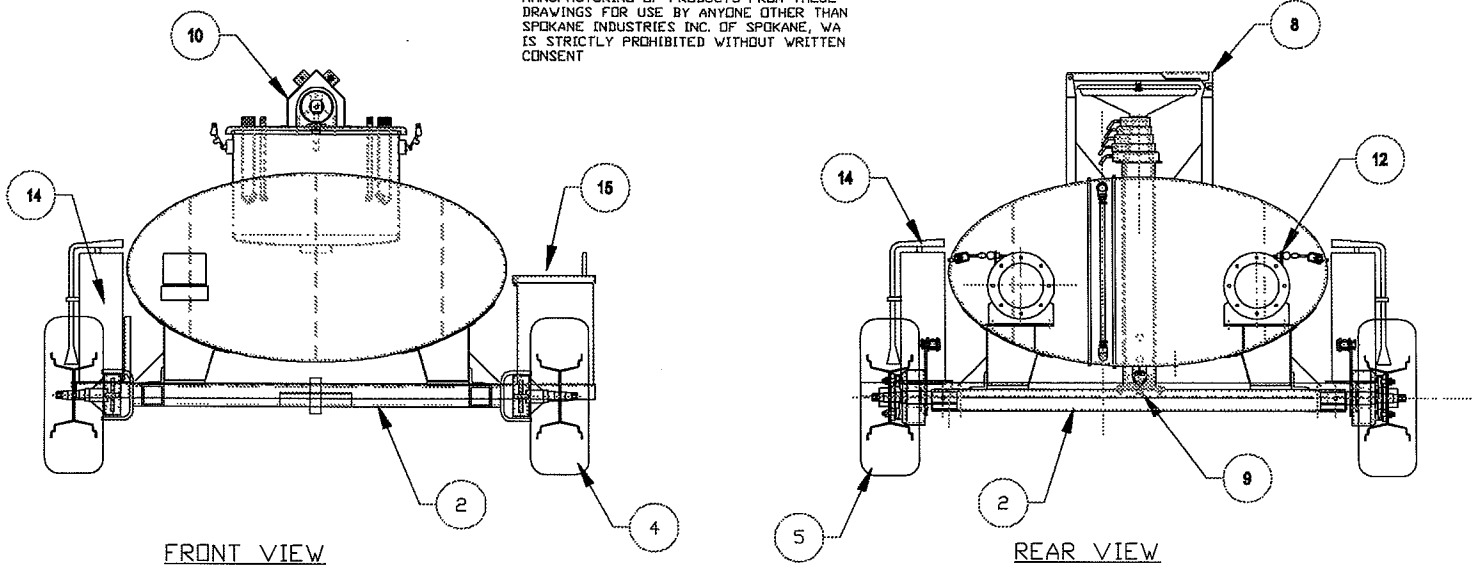

<u>ITEM No.</u>	<u>ASSEMBLY</u>	<u>SECTION</u>
1	Main Tank	5.1
2	Axle Front	5.2.1
2	Axle Rear	5.2.2
3	Tow Bar Actuated Parking Brake	5.2.3
4	Wheel Assembly, Front	5.2.4
5	Wheel Assembly, Rear	5.2.5
6	20" Manway	5.3
7	Decal Package	5.4
8	Telescoping Drain Assembly	5.5
9	Telescoping Drain Sump	5.5.1
10	Vacuum Assembly	5.6
11		5.6.1
12	Miscellaneous Fixtures	5.7
13	Vent/Overflow Preventer	5.8
14	Fire Extinguisher	5.9
15	Tool Box	5.10

CONFIDENTIAL-PROPRIETARY INFORMATION  
REPRODUCTION OF THESE DRAWINGS OR THE  
MANUFACTURING OF PRODUCTS FROM THESE  
DRAWINGS FOR USE BY ANYONE OTHER THAN  
SPOKANE INDUSTRIES INC. OF SPOKANE, WA  
IS STRICTLY PROHIBITED WITHOUT WRITTEN  
CONSENT

## SECTION 5.1

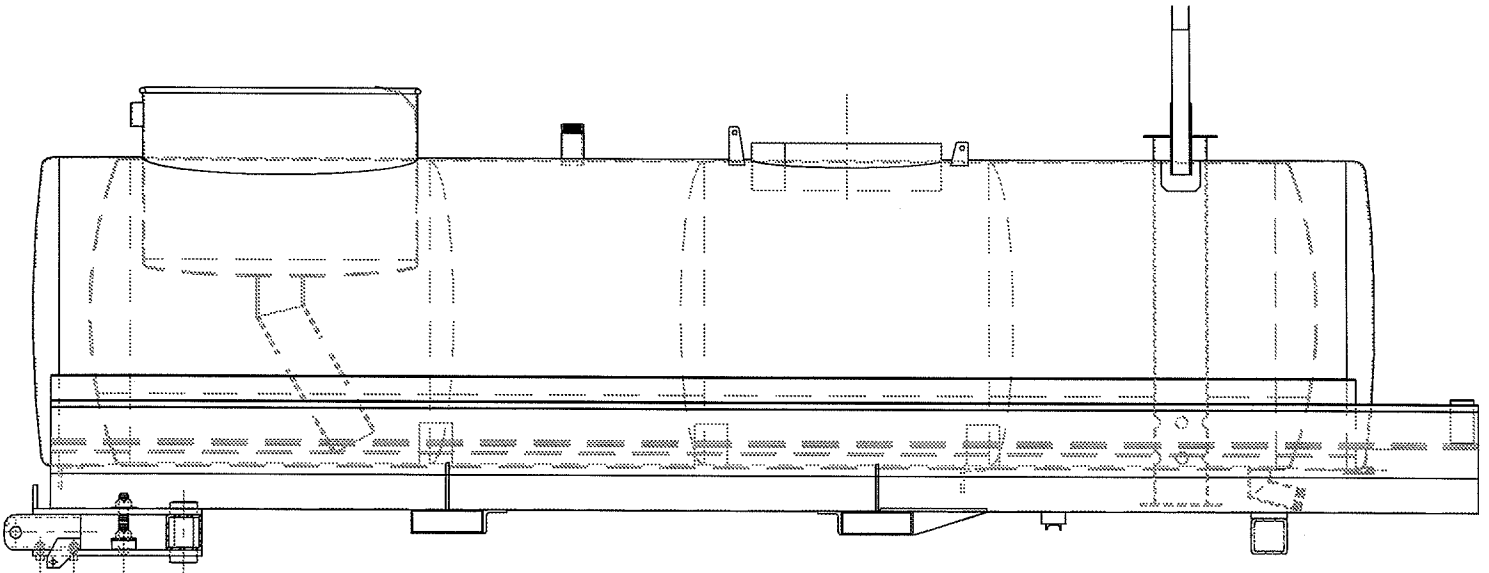

Sub Assy.	Item	Part No.	Quantity	Description	Wt. #'s
-	1	16037	1	Stainless Steel Tank Weldment, 400 Gallon Capacity Double wall Type BOW 400-03	1300#

CONFIDENTIAL-PROPRIETARY INFORMATION  
 REPRODUCTION OF THESE DRAWINGS OR THE  
 MANUFACTURING OF PRODUCTS FROM THESE  
 DRAWINGS FOR USE BY ANYONE OTHER THAN  
 SPOKANE INDUSTRIES INC. OF SPOKANE, WA  
 IS STRICTLY PROHIBITED WITHOUT WRITTEN  
 CONSENT

## SECTION 5.2.1

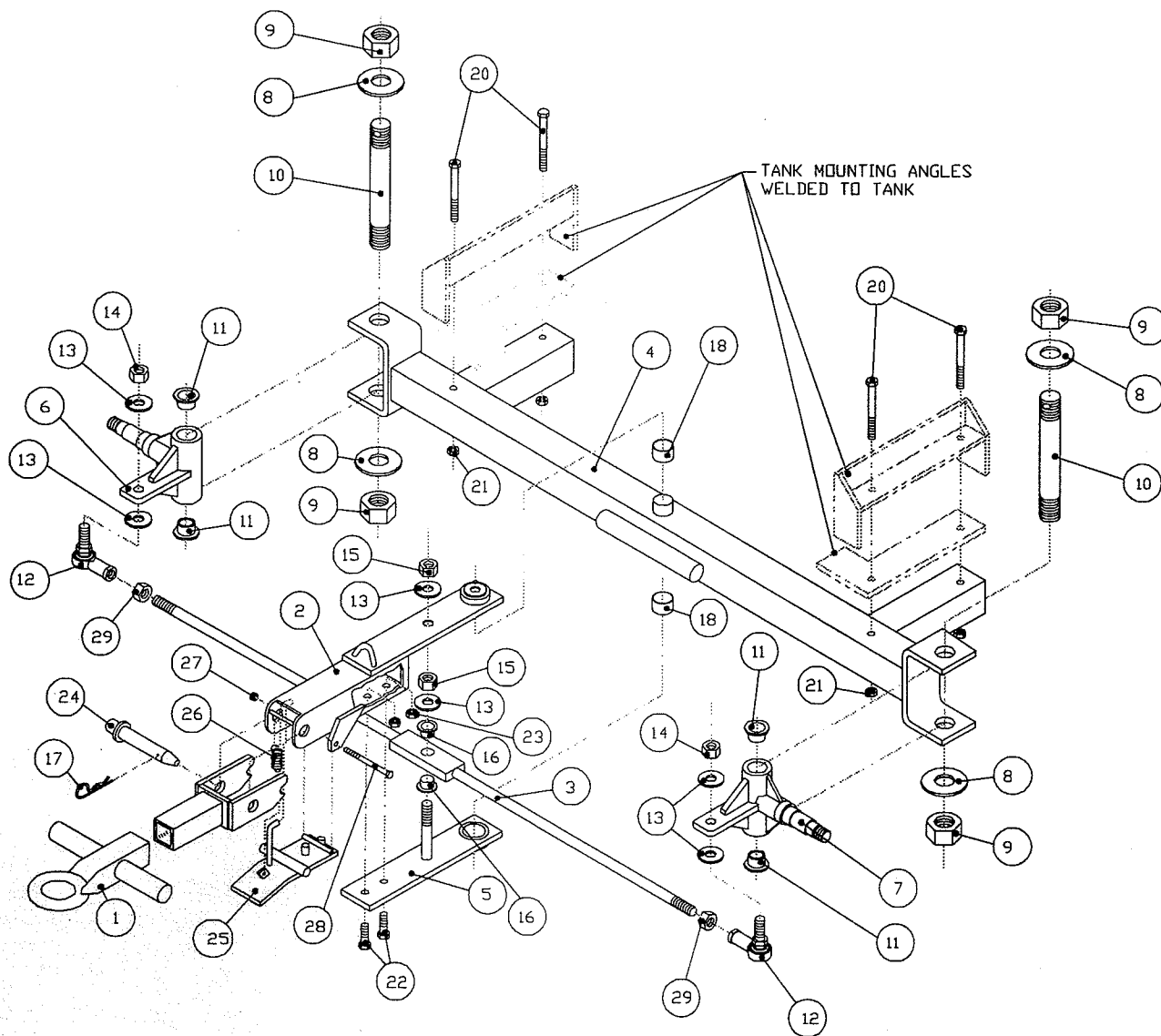

ASSEMBLY No. 08-1018SP  
 MAJOR ASSEMBLY- AXLE ASSEMBLY

Sub Assy.	Item	Part No.	Quantity	Description	Wt. #'s
08-1018	-	-	1	Axle, Assembly, Front	175#
-	1	07-1103SP	1	Tow Bar, Heavy duty	23
-	2	07-1104	1	Arm, Turning	16
-	3	07-1005	1	Tie Rod	8.6
-	4	07-11071	1	Axle, Front	63.3

ASSEMBLY No. 08-1018  
 MAJOR ASSEMBLY- AXLE ASSEMBLY ( CONTINUED )

Sub Assy.	Item	Part No.	Quantity	Description	Wt. #'s
	5	07-1016	1	Steering Arm, Lower Plate	6.7
07-1009	6	05-1009	1	Sleeve, King Pin, Right	12
07-1009	7	05-1009	1	Sleeve, King Pin, Left	12
	8	02-11131	4	Washer, King Pin	.7
	9	02-12131	4	Nut, King Pin	2
	10	05-1010	2	King Pin	11
	11	03-1013	4	Bushing, King Pin Sleeve	1
	12	03-1016	2	Ends, Tie Rod	5
	13	02-11072	5	Washers, Tie Rod	.4
	14	02-12071	2	Nuts, Tie Rod Ends	.6
	15	02-12071	2	Nut, Tie Rod Pivot	.6
	16	03-1015	2	Bushing, Tie Rod Pivot	.8
	17	02-1300	2	Cotter Pin	.2
	18	03-1014	2	Bushing, Axle Pivot	1
	19	-	-	-	-
	20	02-1503	4	Bolts, Tank Mounting	1.3
	21	02-12041	4	Nuts, Tank Mounting	.8
	22	02-1502	2	Bolts, Turning Arm Clamp	.3
	23	02-12041	2	Nuts, Turning Arm Clamp	.4
	24	02-1304	1	Hitch Pin	2
	25	07-1020	1	Toe Latch	3.7
	26	04-1054	1	Sprint, Toe Latch	.5
	27	02-12012	1	Nut, Toe Latch	.6
	28	02-1501	1	Bolt, Toe Latch	.2
	29	02-12141	2	Hex Nut, Tie Rod	.6

CONFIDENTIAL-PROPRIETARY INFORMATION  
 REPRODUCTION OF THESE DRAWINGS OR THE  
 MANUFACTURING OF PRODUCTS FROM THESE  
 DRAWINGS FOR USE BY ANYONE OTHER THAN  
 SPOKANE INDUSTRIES INC. OF SPOKANE, WA  
 IS STRICTLY PROHIBITED WITHOUT WRITTEN  
 CONSENT

## SECTION 5.2.2

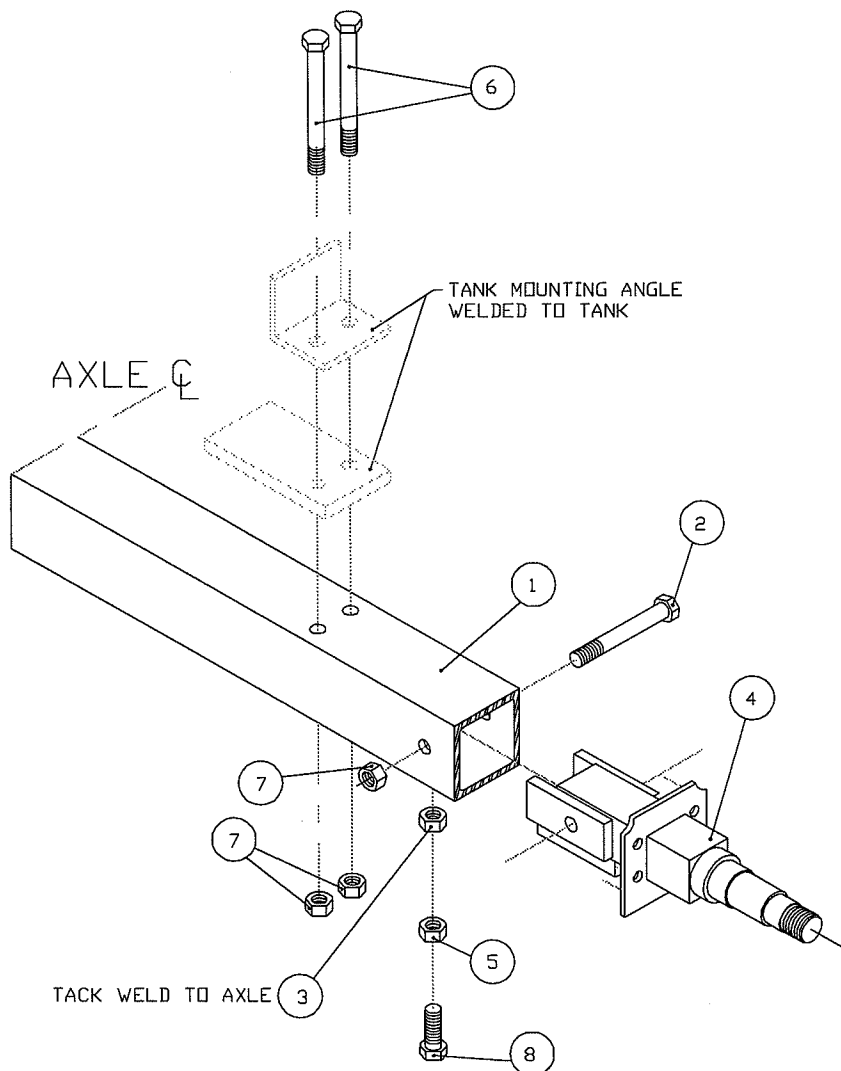

ASSEMBLY No. 08-10102R  
 MAJOR ASSEMBLY-- AXLE ASSEMBLY

Sub Assy.	Item	Part No.	Quantity	Description	Wt. #'s
08-10102R	-	-	1	Axle, Assembly, Rear	72#
-	1	05-1023	1	Axle,Rear	41.9
-	2	02-1505	2	Bolts, Mounting Spindle	2
-	3	02-12035	2	Nuts, Mounting Spindle	1
-	4	07-1010R	2	Spindle, Rear	20
-	5	02-1203	2	Nut, Mounting Spindle	1
-	6	02-1503	4	Bolt, Mounting Angles	2
-	7	02-1204	6	Nuts, Mounting	3
-	8	02-10041	2	Bolt, Mounting Spindle	1.5

CONFIDENTIAL-PROPRIETARY INFORMATION  
 REPRODUCTION OF THESE DRAWINGS OR THE  
 MANUFACTURING OF PRODUCTS FROM THESE  
 DRAWINGS FOR USE BY ANYONE OTHER THAN  
 SPOKANE INDUSTRIES INC. OF SPOKANE, WA  
 IS STRICTLY PROHIBITED WITHOUT WRITTEN  
 CONSENT

SECTION 5.2.3

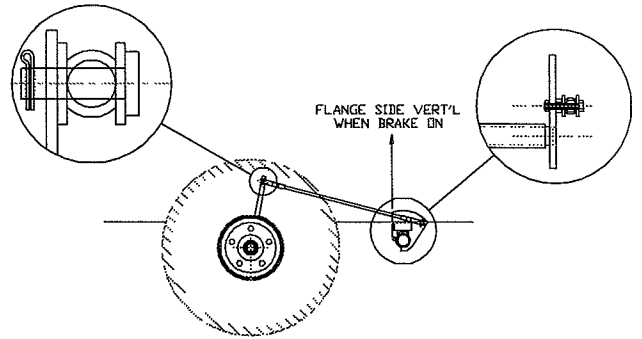
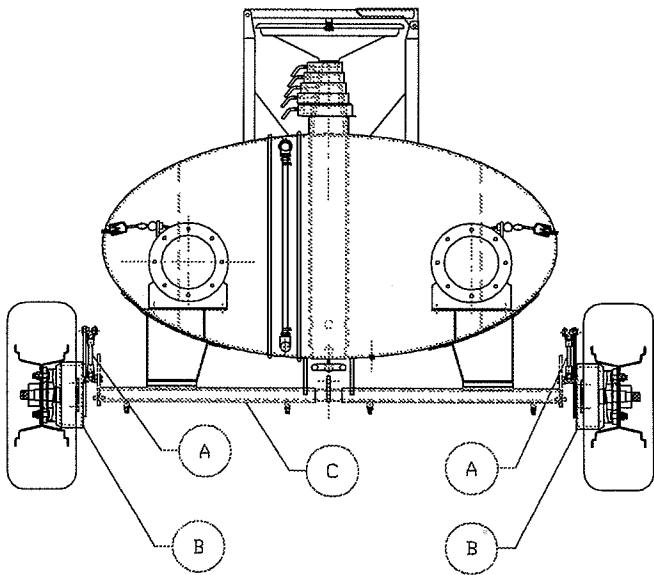

A BRAKE LINKAGE ASSEMBLY  
 SECTION 5.2.3-A

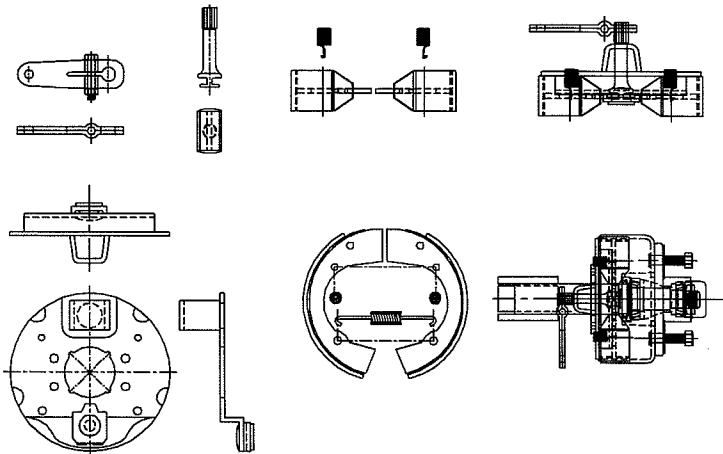

B BRAKE ASSEMBLY  
 SECTION 5.2.3-B

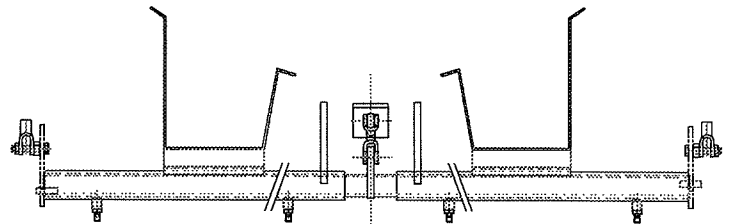

C BRAKE SLEEVE ASSEMBLY  
 SECTION 5.2.3-C

ASSEMBLY No. 10-100030SP  
 MAJOR ASSEMBLY- TOW BAR ACTUATED PARKING BRAKE

Sub Assy.	Item	Part No.	Quantity	Description	Wt. #'s
10-100030SP	-	-	1	Brake Assembly	45#
-	A	08-1008SP	1	Brake Linkage Assembly	14.3
-	B	08-1007R	1	Brake Assembly	17.9
-	C	07-1038SP	1	Brake Sleeve Assembly	8.6

CONFIDENTIAL-PROPRIETARY INFORMATION  
 REPRODUCTION OF THESE DRAWINGS OR THE  
 MANUFACTURING OF PRODUCTS FROM THESE  
 DRAWINGS FOR USE BY ANYONE OTHER THAN  
 SPOKANE INDUSTRIES, INC. OF SPOKANE, WA  
 IS STRICTLY PROHIBITED WITHOUT WRITTEN  
 CONSENT

SECTION 5.2.3-A

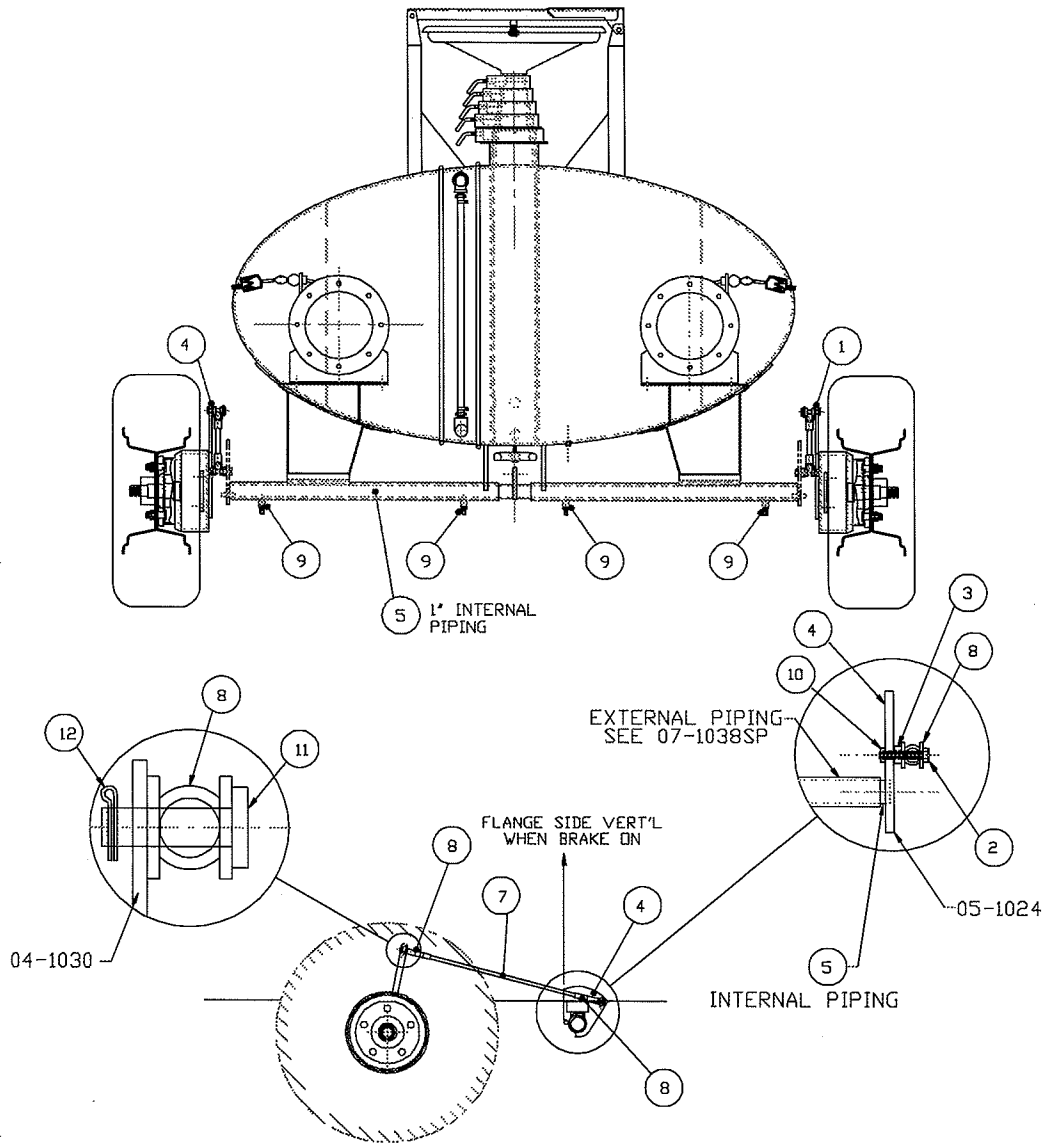

ASSEMBLY No. 08-1008SP  
 MAJOR ASSEMBLY- BRAKE ASSEMBLY

Sub Assy.	Item	Part No.	Quantity	Description	Wt. #'s
08-1008SP			1	Brake Linkage Assembly	14.3#
	1	05-1025	1	Cam, Brake Linkage, Right	1.4
	2	02-10012	2	Bolt, Cam	1.6
	3	02-12021	2	Nut, Cam	.4
	4	05-1024	1	Cam, Brake Linkage, Left	1.4
	5	01-8104	1	Shaft, Brake	7.5
	6	-	-	-	-
	7	05-1026	2	Rod, Brake	.5
	8	04-2516	4	Yoke End	.5
	9	03-1020	4	Grease Fitting	.5
	10	02-100231	2	Nut, Jam	.5
	11	08-1008SP-11	2	Pin	.1
	12	08-1008SP-12	2	Pin, Cotter	.1

CONFIDENTIAL-PROPRIETARY INFORMATION  
 REPRODUCTION OF THESE DRAWINGS OR THE  
 MANUFACTURING OF PRODUCTS FROM THESE  
 DRAWINGS FOR USE BY ANYONE OTHER THAN  
 SPOKANE INDUSTRIES INC. OF SPOKANE, WA  
 IS STRICTLY PROHIBITED WITHOUT WRITTEN  
 CONSENT

SECTION 5.2.3-B

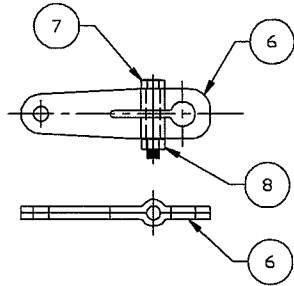

CAM LEVER OPERATOR DETAIL

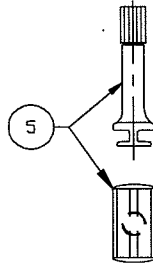

CAM DETAIL

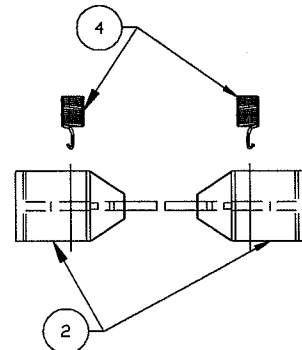

BRAKE SHOE / HOLD DOWN SPRING DETAIL

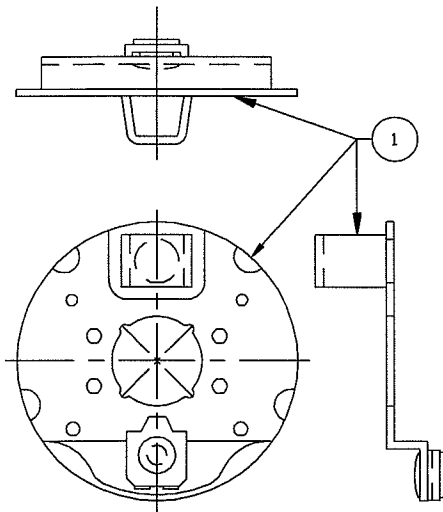

BACKING PLATE DETAIL

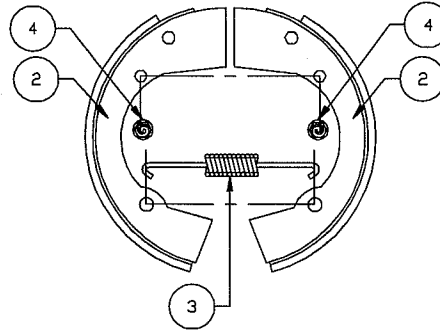

BRAKE SHOE / SPRING ORIENTATION  
 RETURN SPRING

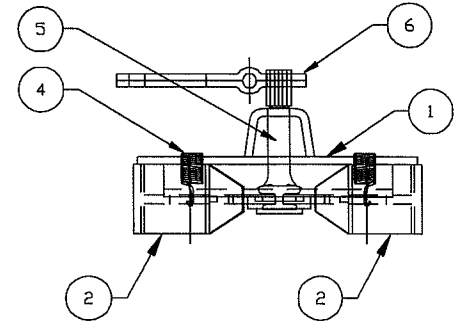

BRAKE/CAM/LEVER/BACKING PLATE ASSY

ASSEMBLY No. 08-1007R  
 MAJOR ASSEMBLY- BRAKE ASSEMBLY

Sub Assy.	Item	Part No.	Quantity	Description	Wt. #'s
08-1007R		-	1	MECHANICAL BRAKE ASSEMBLY PRE ASSEMBLED	4.4#
	1	04-1064R	1	Brake Plate Assembly	1.4
	2	04-1065R	2	Brake Shoe Assembly	1.6
	3	04-10265R	1	Return Spring	-
	4	04-1026R	2	Brake Shoe Hold Down Spring	-
	5	04-1028R	1	Cam	.5
	6	04-1030R	1	Cam Lever	.7
	7	02-10017R	1	Lever Bolt	-
	8	02-12012	1	Lever Nut	-

CONFIDENTIAL-PROPRIETARY INFORMATION  
 REPRODUCTION OF THESE DRAWINGS OR THE  
 MANUFACTURING OF PRODUCTS FROM THESE  
 DRAWINGS FOR USE BY ANYONE OTHER THAN  
 SPOKANE INDUSTRIES INC. OF SPOKANE, WA  
 IS STRICTLY PROHIBITED WITHOUT WRITTEN  
 CONSENT

SECTION 5.2.3-C

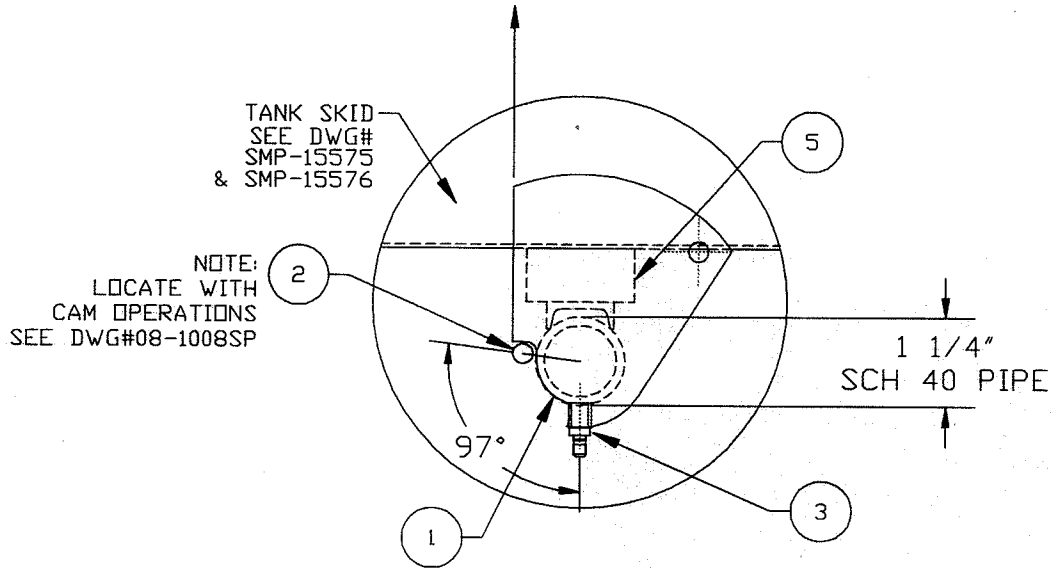
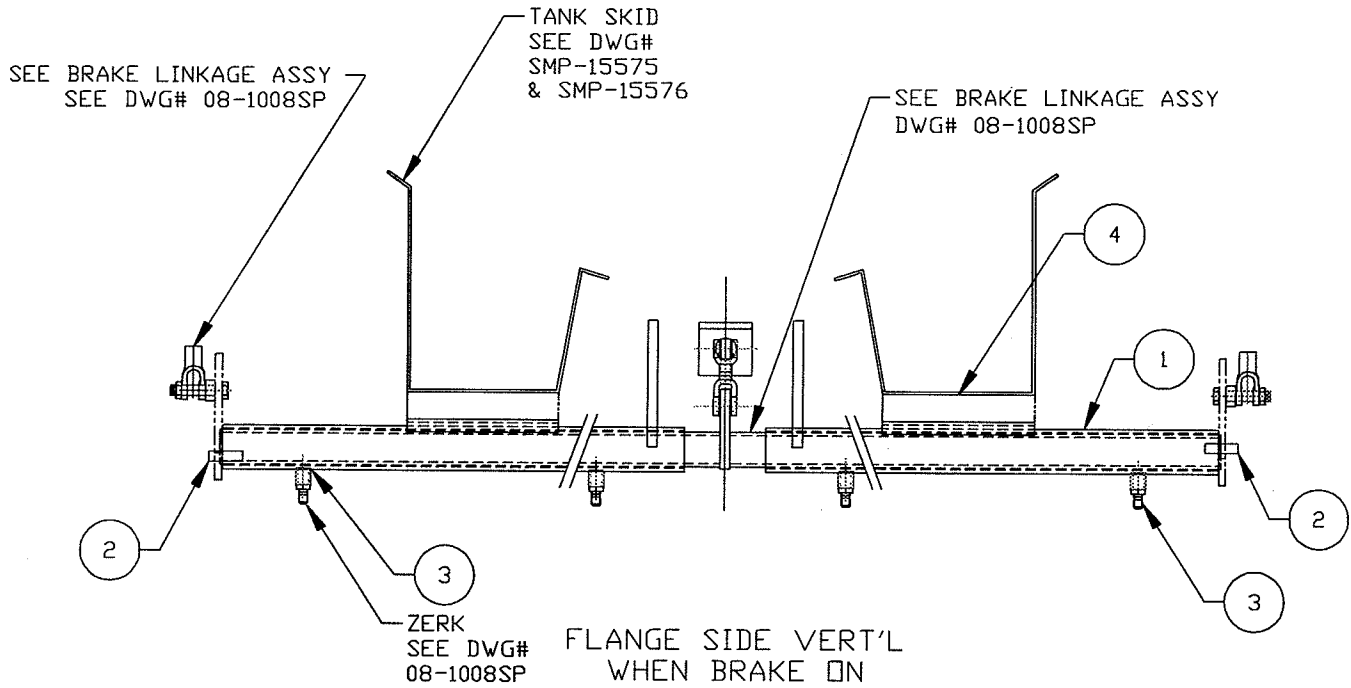

ASSEMBLY No. 07-1038SP  
 MAJOR ASSEMBLY- BRAKE ASSEMBLY

Sub Assy.	Item	Part No.	Quantity	Description	Wt. #'s
07-1038SP		-	1	BRAKE SLEEVE ASSEMBLY	13#
	1	01-8031	1	Sleeve, Brake Assembly	7.4
	2	01-9124	2	Stop, Cam	.08
	3	03-0371	4	Coupling, Zirk	.03
	4	01-8545	2	Mount, Cannel	.49
	5	01-9791	2	Spacer	5.0

SECTION 5.2.4

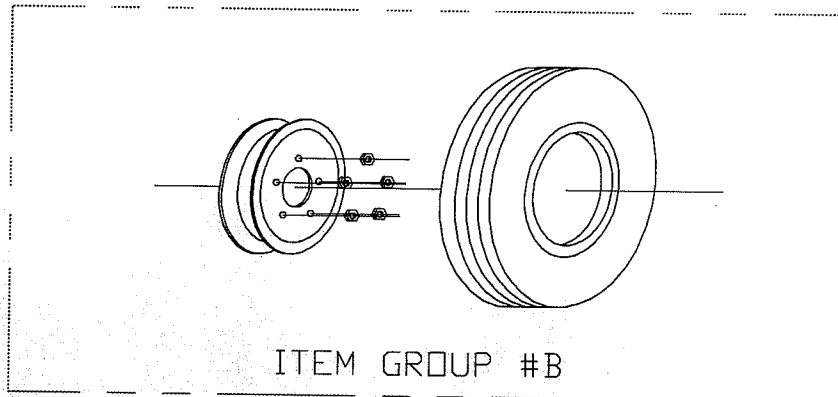
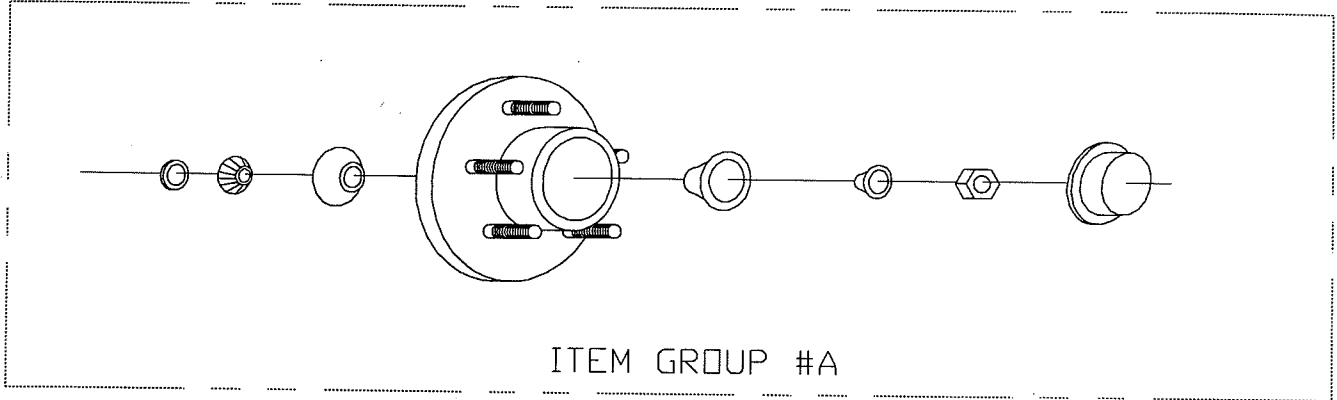

ASSEMBLY No. 10-100042  
 MAJOR ASSEMBLY- FRONT WHEEL

Sub Assy.	Item	Part No.	Quantity	Description	Wt. #'s
10-100042	-	-	2	FRONT WHEEL ASSEMBLY	116#
-	A	08-1011	1	Bearing And Hub Assembly, Front	23
-	B	08-10061	1	Tire/Wheel/Tube Assembly	35

SECTION 5.2.4-A

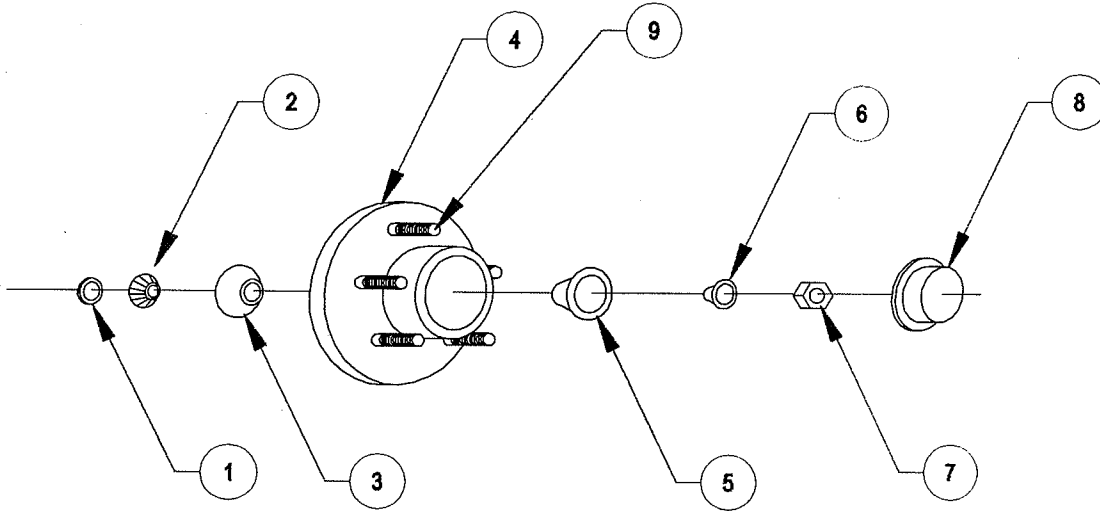

ASSEMBLY No. 08-1011  
 MAJOR ASSEMBLY- FRONT WHEEL

Sub Assy.	Item	Part No.	Quantity	Description	Wt. #'s
08-1011		04-1050	1	Bearing and Hub Assembly, Front	23#
	1	04-1012	1	Seal, Bearing	1
	2	04-1013	1	Bearing, Inner	3
	3	04-1015	1	Cup, Inner	2
	4	04-1017	1	Hub, Wheel	7
	5	04-1016	1	Cup, Outer	4
	6	04-1014	1	Bearing, Outer	3
	7	02-1205	1	Nut, Spindle	1
	8	04-1019	1	Cap, Dust	1
	9	02-1017	5	Studs, Hub	1

SECTION 5.2.4-B

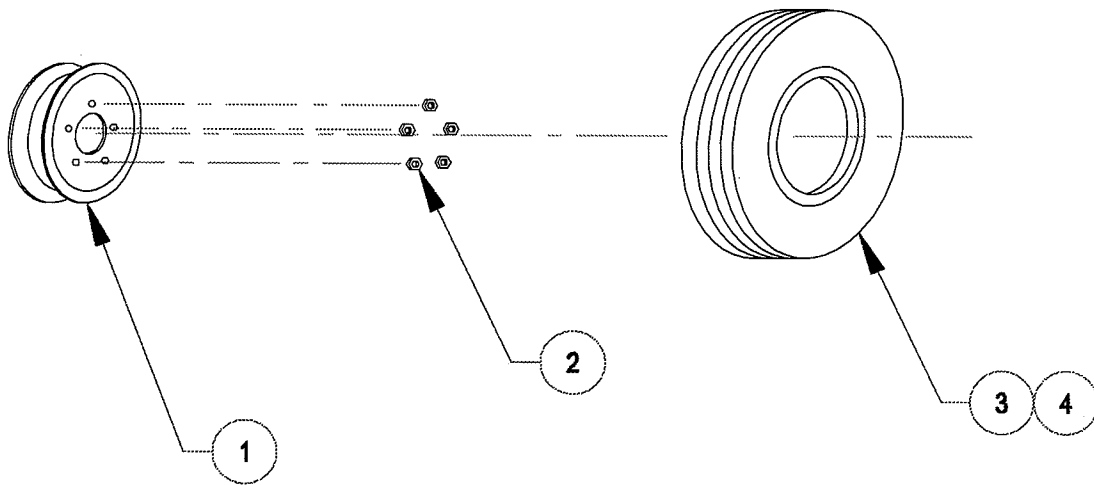

ASSEMBLY No. 08-10061  
 MAJOR ASSEMBLY- FRONT WHEEL

Sub Assy.	Item	Part No.	Quantity	Description	Wt. #'s
08-10061	-	-	1	Tire/Wheel/Tube Assembly	35#
-	1	04-1020	1	Wheel, Split Rim	19
-	2	04-1021	5	Nuts, Lug	1
-	3	04-10221	1	Tire	4
-	4	04-1045	1	Tube	11

CONFIDENTIAL-PROPRIETARY INFORMATION  
 REPRODUCTION OF THESE DRAWINGS OR THE  
 MANUFACTURING OF PRODUCTS FROM THESE  
 DRAWINGS FOR USE BY ANYONE OTHER THAN  
 SPOKANE INDUSTRIES INC. OF SPOKANE, WA  
 IS STRICTLY PROHIBITED WITHOUT WRITTEN  
 CONSENT

SECTION 5.2.5

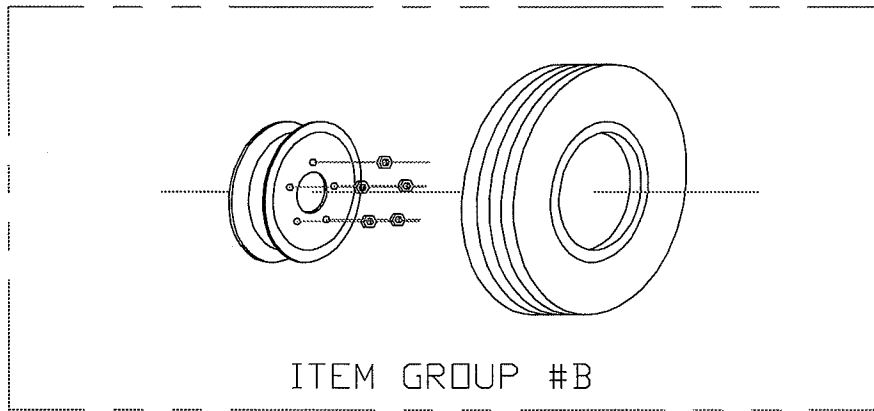
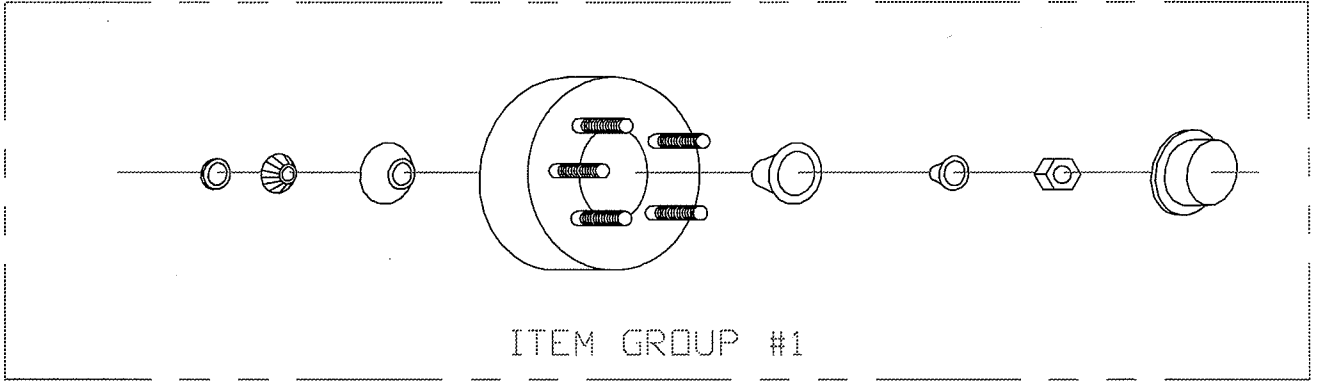

ASSEMBLY No. 10-100052R  
 MAJOR ASSEMBLY- REAR WHEEL

Sub Assy.	Item	Part No.	Quantity	Description	Wt. #'s
10-100052R	-	-	2	REAR WHEEL ASSEMBLY	136.3#
-	A	08-10111R	1	Bearing And Hub Assembly, Front	32.6
-	B	08-10061	1	Tire/Wheel/Tube Assembly	35

SECTION 5.2.5-A

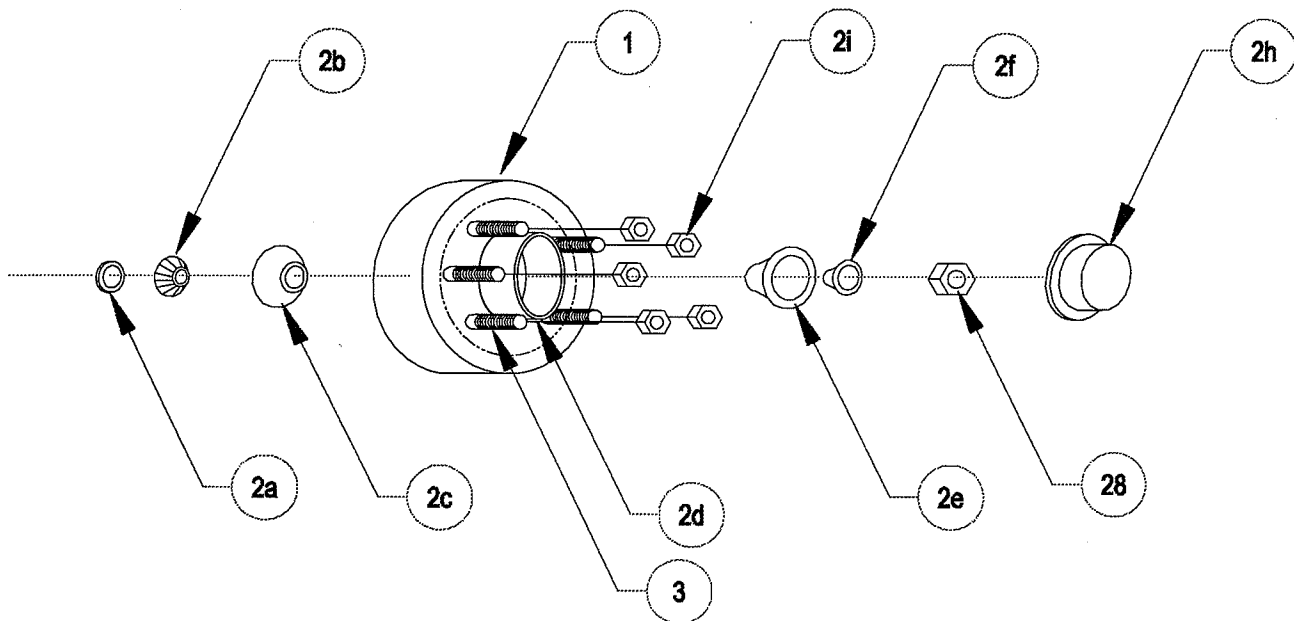

ASSEMBLY No. 08-10111R  
 MAJOR ASSEMBLY- REAR WHEEL

Sub Assy.	Item	Sub#	Part No.	Quantity	Description	Wt. #'s
08-10111R				1	Bearing and Hub Assembly, Rear	20.0#
05-1008R				1	Bearing and Hub Assembly, Rear	20.0#
	1		05-1021R		Brake Drum	6.3
		1a		1	Brake Drum ( 04-1051 )	
	2		04-1050R		Hub and Bearing Assembly, Rear	11.4
		2a		1	Seal, Bearing ( 04-1012 )	1.1 oz
		2b		1	Bearing, Inner ( 04-1013 )	4.2 oz
		2c		1	Cup, Inner ( 04-1015 )	2.6 oz
		2d		1	Machined Hub ( 05-1020 )	9.0
		2e		1	Cup, Outer ( 04-1016 )	1.6 oz
		2f		1	Bearing, Outer ( 04-1014 )	3.1 oz
		2g		1	Nut, Spindle ( 02-1205 )	2.1 oz
		2h		1	Cap, Dust ( 04-1019 )	1.3 oz
		2i		5	Nut, Lug ( 02-1021 )	6.4 oz
	3		02-1017	5	Studs, Hub	2.3

CONFIDENTIAL-PROPRIETARY INFORMATION  
 REPRODUCTION OF THESE DRAWINGS OR THE  
 MANUFACTURING OF PRODUCTS FROM THESE  
 DRAWINGS FOR USE BY ANYONE OTHER THAN  
 SPOKANE INDUSTRIES INC. OF SPOKANE, WA  
 IS STRICTLY PROHIBITED WITHOUT WRITTEN  
 CONSENT

SECTION 5.2.5-B

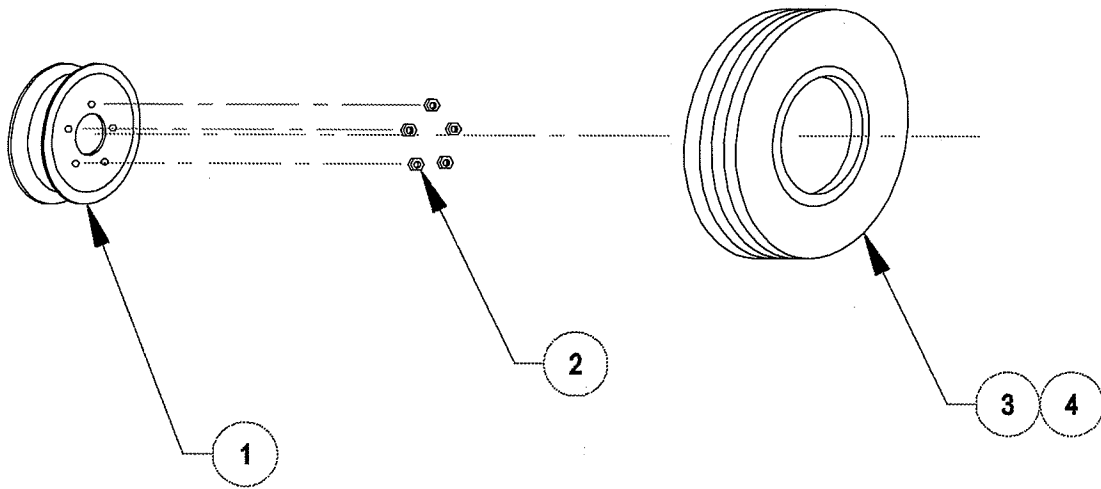

ASSEMBLY No. 08-10061  
 MAJOR ASSEMBLY- FRONT WHEEL

Sub Assy.	Item	Part No.	Quantity	Description	Wt. #'s
08-10061	-	-	1	Tire/Wheel/Tube Assembly	35#
-	1	04-1020	1	Wheel, Split Rim	19
-	2	04-1021	5	Nuts, Lug	1
-	3	04-10221	1	Tire	4
-	4	04-1045	1	Tube	11

CONFIDENTIAL-PROPRIETARY INFORMATION  
 REPRODUCTION OF THESE DRAWINGS OR THE  
 MANUFACTURING OF PRODUCTS FROM THESE  
 DRAWINGS FOR USE BY ANYONE OTHER THAN  
 SPOKANE INDUSTRIES INC. OF SPOKANE, WA  
 IS STRICTLY PROHIBITED WITHOUT WRITTEN  
 CONSENT

### SECTION 5.3

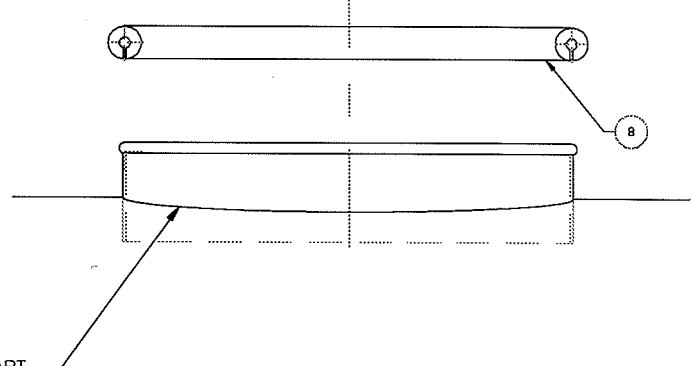
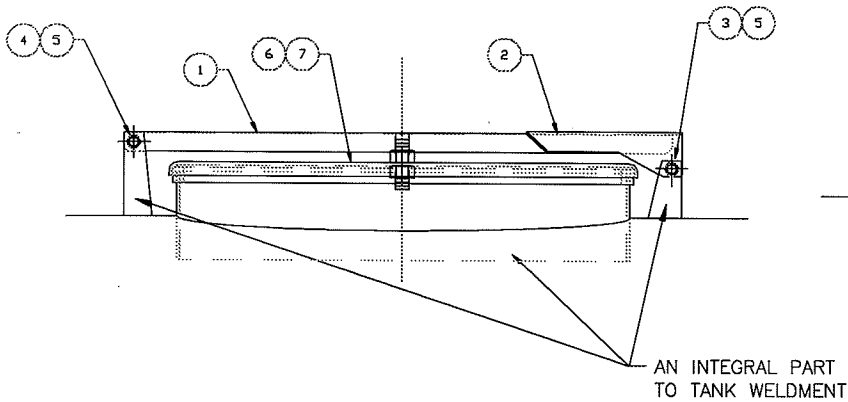
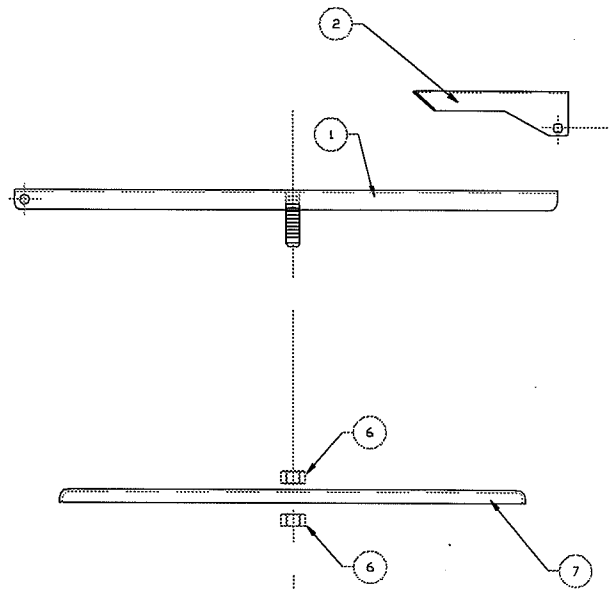
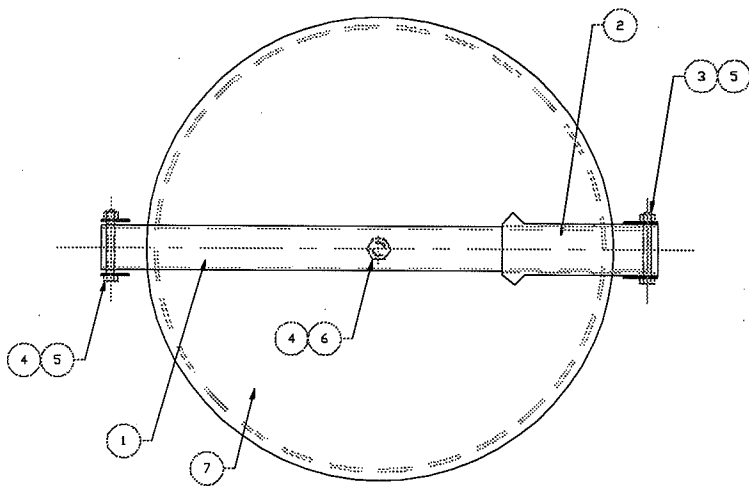

ASSEMBLED DETAIL

EXPLODED DETAIL

ASSEMBLY No. SMP-775  
 MAJOR ASSEMBLY- 20" QUICK OPENING MANWAY

Sub Assy.	Item	Part No.	Quantity	Description	Wt. #'s
SMP-775			1	MANWAY ASSEMBLY	22.5#
	1	01-903S	1	Large Cross Arm	3.3
	2	01-8222S	1	Small Cross Arm	1.3
	3	02-10013	1	Bolt, Small Cross Arm	.2
	4	02-10013	1	Bolt, Large Cross Arm	.2
	5	775-5	2	Nuts, Cross Arms	.3
	6	02-20611S	2	Nuts, Lid	.5
	7	01-9005S	2	Lid	14.9
	8	06-1022	2	Gasket	1.8

CONFIDENTIAL-PROPRIETARY INFORMATION  
 REPRODUCTION OF THESE DRAWINGS OR THE  
 MANUFACTURING OF PRODUCTS FROM THESE  
 DRAWINGS FOR USE BY ANYONE OTHER THAN  
 SPOKANE INDUSTRIES INC. OF SPOKANE, WA  
 IS STRICTLY PROHIBITED WITHOUT WRITTEN  
 CONSENT

SECTION 5.4

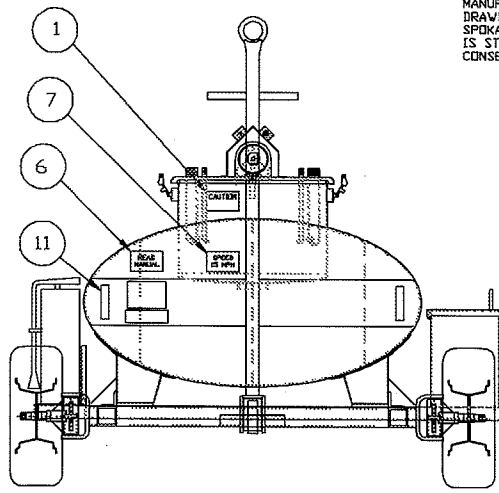

FRONT VIEW

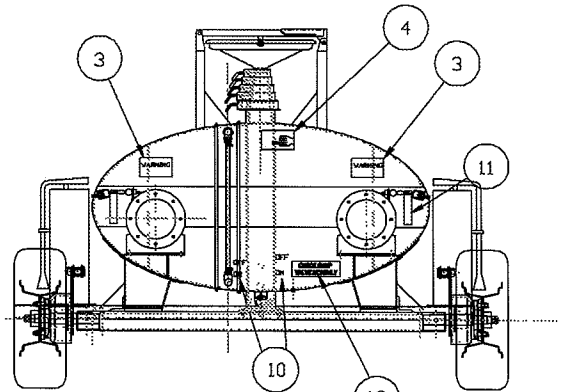

REAR VIEW

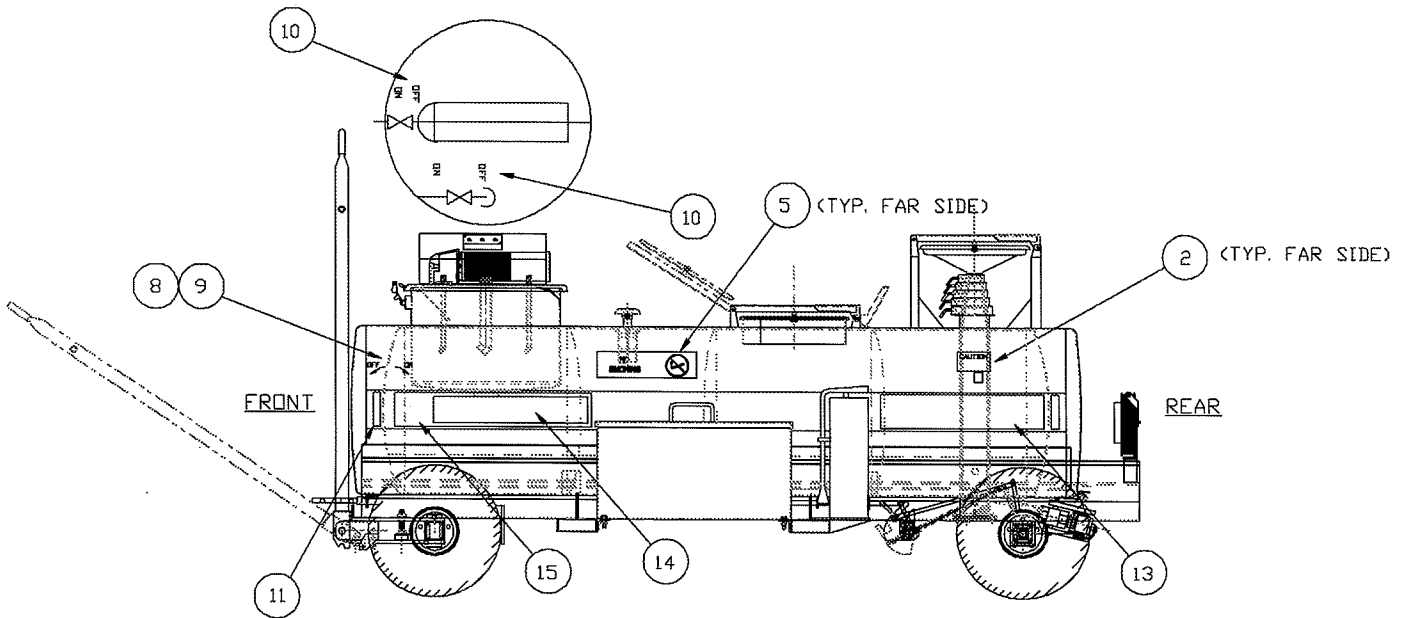

ASSEMBLY No. 10-100070  
 MAJOR ASSEMBLY- DECAL PACKAGE

Sub Assy.	Item	Part No.	Quantity	Description	Wt. #'s
10-100070	-	-	1	DECAL PACKAGE	2.7#
	1	06-1002	1	Caution-Vacuum Pressure	.1
	2	06-1003	1	Caution-Park Brake	.1
	3	06-1004	2	Warning-Grounding Reels	.1
	4	06-1005	1	Warnign-Pinch Point	.1
	5	06-1006	2	Danger-No Smoking	.2
	6	06-1007	1	Notice-Read Manual	.1
	7	06-1008	1	Maximum Tow Speed	.1
	8	06-1010	1	On/Off-Park Brake	.1
	9	06-1010	1	On/Off-Park Brake	.1
	10	06-1011	8	On/Off Drain Valve	.8
	11	10-100070-11	8	Reflector Tape, 6" lg.	.8
	12	10-100070-12	1	Check Sump Valve Monthly	.1
	13	06-1020	2	Defueler Sticker, Black	.1
UASU#	14	-	2	United SU# -----	.1
UAREFL	15	-	2	United Logo/ Reflector	.1

CONFIDENTIAL-PROPRIETARY INFORMATION  
REPRODUCTION OF THESE DRAWINGS OR THE  
MANUFACTURING OF PRODUCTS FROM THESE  
DRAWINGS FOR USE BY ANYONE OTHER THAN  
SPOKANE INDUSTRIES INC. OF SPOKANE, WA  
IS STRICTLY PROHIBITED WITHOUT WRITTEN  
CONSENT

SECTION 5.5

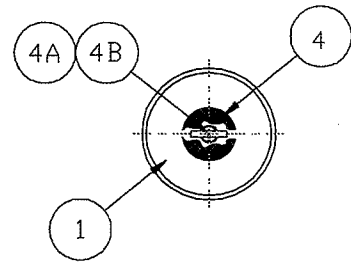
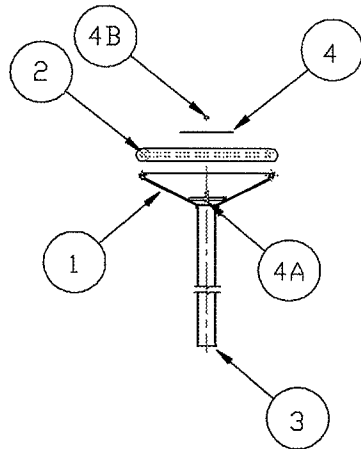
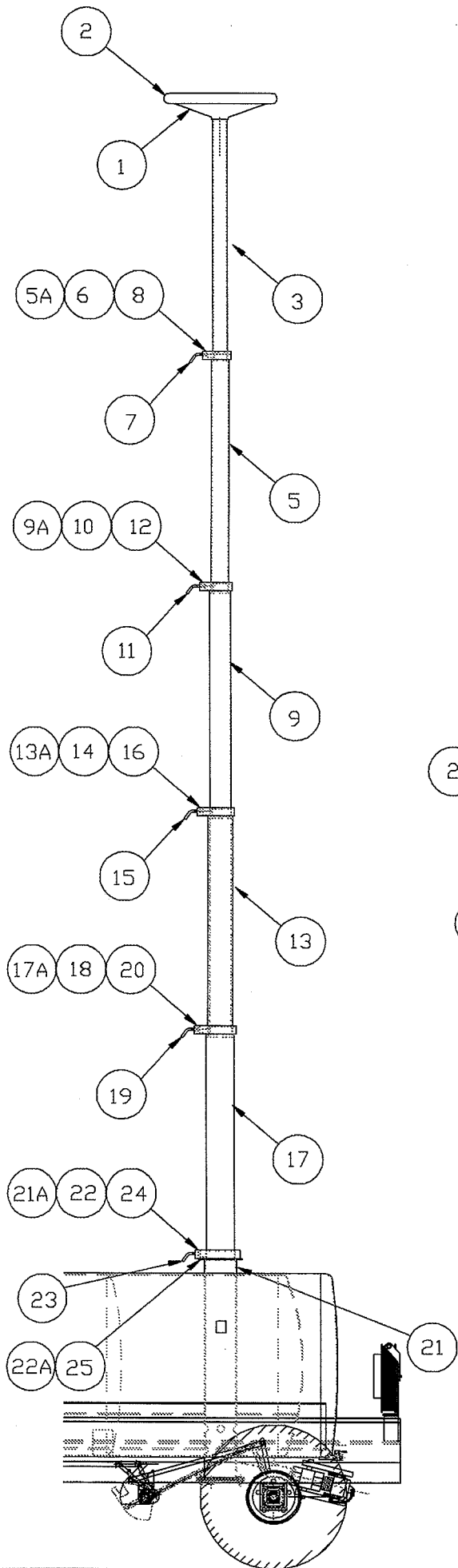

REAR

ASSEMBLY No. 08-1034USP  
 MAJOR ASSEMBLY- TELESCOPING DRAIN

Sub Assy.	Item	Part No.	Quantity	Description	Wt. #'s
08-1034U			1	TELESCOPING DRAIN ASSEMBLY	30#
08-1016U		07-10541	1	Funnel Section Assembly	
	1	01-8250	1	Funnel, Cast	2.4
	2	06-1022T	1	Gasket	.2
	3	01-92402	1	Tubing, 2"OD	3.5
	4	04-1039	1	Screen	.1
	4A	02-10002	1	Bolt, Carriage	.2
	4B	02-1200	1	Nut, Nylon Lock	.1
08-1017U			1	2 1/2" Section Assembly	
	5A	05-10271	1	Clamp(Clamps 08-1016U Assy)	2.1
	5	01-9242	1	Tubing, 2 1/2"OD	1.1
	6	05-10051	1	Wedge For 05-10271 Clamp	.3
	7	05-10181	1	Handle, Clamp	.3
	8	02-1005	1	Screw, Set ( For Wedge )	.1
08-1027U			1	3" Section Assembly	
	9A	05-10281	1	Clamp(Clamps 08-1017U Assy)	2.3
	9	01-92452	1	Tubing, 3"OD	1.4
	10	05-10021	1	Wedge for 05-10281 Clamp	.3
	11	05-10181	1	Handle, Clamp	.3
	12	02-1005	1	Screw, Set ( For Wedge )	.1
08-1028U			1	3 1/2" Section Assembly	
	13A	05-10291	1	Clamp(Clamps 08-1027U Assy)	2.6
	13	01-9248	1	Tubing, 3 1/2"OD	1.6
	14	05-10031	1	Wedge For 05-10291 Clamp	.3
	15	05-10181	1	Handle, Clamp	.3
	16	02-1005	1	Screw, Set ( For Wedge )	.1
07-1014USP			1	4" Section Assembly	
	17A	05-10301	1	Clamp(Clamps 08-1028U Assy)	2.7
	17	01-9259	1	Tubing, 4"OD	1.1
	18	05-10041	1	Wedge For 05-10301 Clamp	.3
	19	05-10181	1	Handle, Clamp	.3
	20	02-1005	1	Screw, Set ( For Wedge )	.1
07-1041USP			1	4 1/2" Section Assembly	
	21A	05-10302	1	Base Clamp(Clamps 07-1014USP Assy)	6.5
	21	01-92565S	1	Tubing, 4 1/2"OD	3.7
	22A	04-10561	1	Flange, Base	.5
	22	05-10051	1	Wedge For 05-10301 Clamp	.3
	23	05-10181	1	Handle, Clamp	.3
	24	02-1005	1	Screw, Set ( For Wedge )	.1
	25	02-100121	4	Bolts, Mounting	.1

CONFIDENTIAL-PROPRIETARY INFORMATION  
 REPRODUCTION OF THESE DRAWINGS OR THE  
 MANUFACTURING OF PRODUCTS FROM THESE  
 DRAWINGS FOR USE BY ANYONE OTHER THAN  
 SPOKANE INDUSTRIES INC. OF SPOKANE, WA  
 IS STRICTLY PROHIBITED WITHOUT WRITTEN  
 CONSENT

SECTION 5.5.1

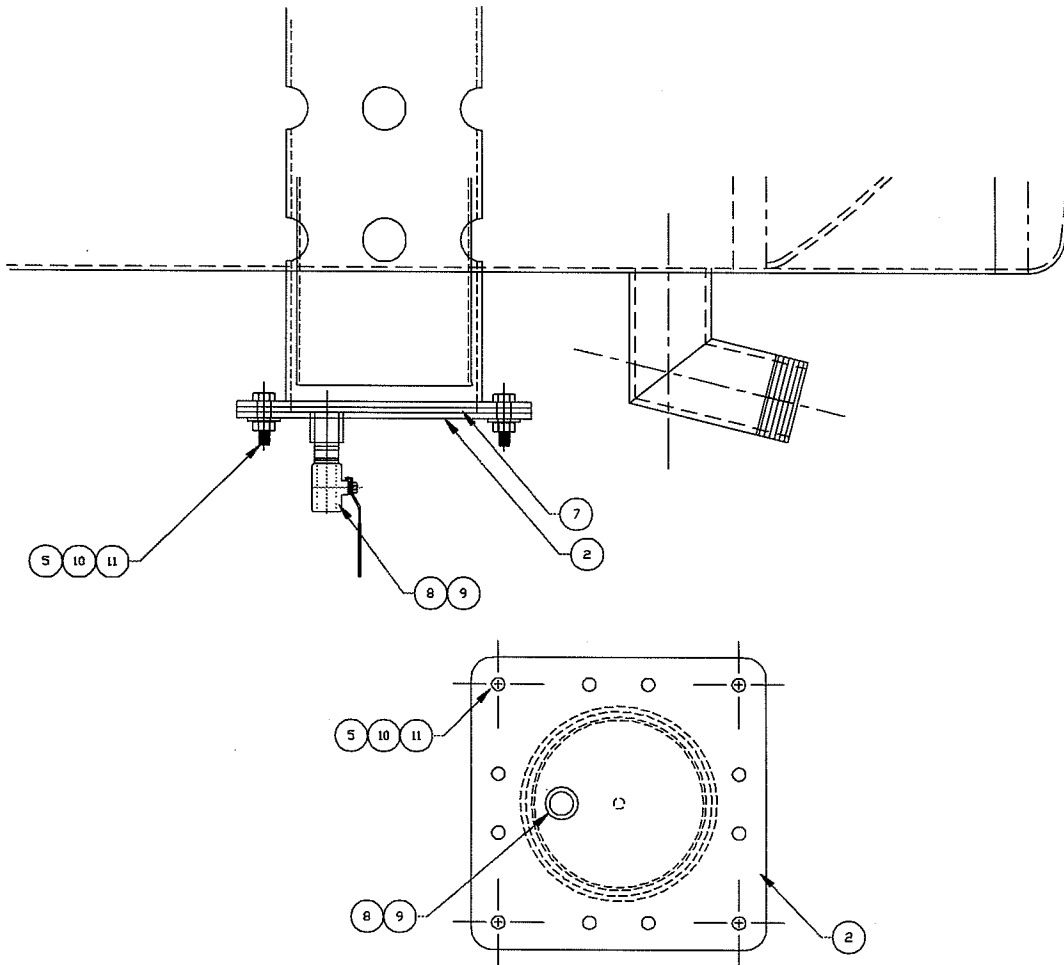

MATING FLANGE AND ASSEMBLY DETAILS

ASSEMBLY No. SMP-16037SP  
 MAJOR ASSEMBLY- TELESCOPING DRAIN SUMP

Sub Assy.	Item	Part No.	Quantity	Description	Wt. #'s
SMP-16037SP			1	Telescoping Drain Sump W/ Stopper Assembly	5.2#
	1	-	-	-	-
	2	01-9005S	1	Flange, Mating	2.0
	3	-	-	-	-
	4	-	-	-	-
	5	02-12140	4	Nut, 1/4"-unc Hex	.1
	6	-	-	-	-
	7	06-2506	1	Gasket	.2
	8	03-0170S	1	Nipple, 1/4" Close	.2
	9	04-2506	1	Valve, 1/4" Ball	.3
	10	02-1100	12	Bolt, 1/4"-unc x 1" Lg	2.1
	11	02-11001	12	Washer, Lock	.3

CONFIDENTIAL-PROPRIETARY INFORMATION  
REPRODUCTION OF THESE DRAWINGS OR THE  
MANUFACTURING OF PRODUCTS FROM THESE  
DRAWINGS FOR USE BY ANYONE OTHER THAN  
SPOKANE INDUSTRIES INC. OF SPOKANE, WA  
IS STRICTLY PROHIBITED WITHOUT WRITTEN  
CONSENT

### SECTION 5.6

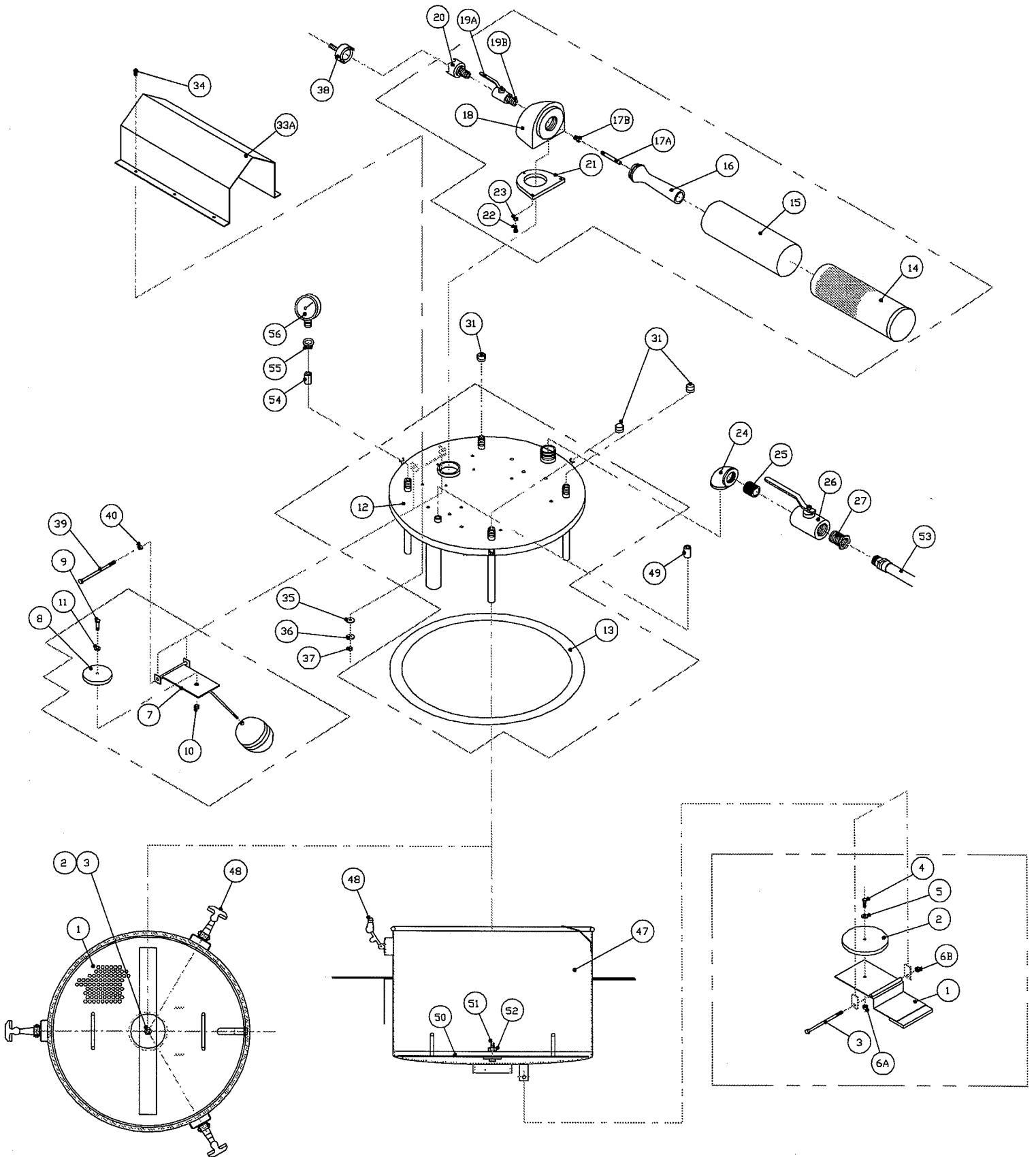

ASSEMBLY No. 08-0002USP  
MAJOR ASSEMBLY- VACUUM SYSTEM

Sub Assy.	Item	Part No.	Quantity	Description	Wt. #'s
08-0002USP			1	VACUUM SYSTEM ASSEMBLY	170#
08-1000	1	07-1000	1	Drain Stop Arm ( Optional )	3.5
	2	04-1000	1	Gasket ( Optional )	.1
	3	02-10016	1	Bolt ( Optional )	.1
	4	02-10002	1	Bolt ( Optional )	.1
	5	02-1100	1	Washer, Flat ( Optional )	.1
	6A	02-1201	1	Nut ( Optional )	.1
	6B	02-1200	1	Nut ( Optional )	.1
08-1001			1	Overflow Stop Assembly	
	7	07-1001	1	Float Assembly	4
	8	04-1001	1	Gasket	.1
	9	02-10003	1	Bolt	.1
	10	02-1200	1	Nut, Nylon Lock	.1
	11	02-1102	1	Washer, Flat	.1
08-1002	12		1	Cover Assembly	29.6
06-1022V	13		1	Gasket	3.5
08-1003			1	Vacuum Generator Assembly	
	14	04-1004	1	Housing, Exhaust	9.5
	15	04-1005	1	Silencer	4.7
	16	04-1006	1	Venturi	2.2
	17A	04-1007	1	Jet, Air	2.7
	17B	03-11135	1	Reducer, Air Jet	.1
	18	04-1008	1	Box, Venturi	2.7
	19A	04-1032	1	Valve, Ball	5.8
	19B	03-0264S	1	Nipple	.2
	20	04-1056	1	Coupler, Air Twist	.7
	21	04-1010	1	Gasket	.1
	22	02-10010	3	Bolt	.1
	23	02-11002	3	Washer, Lock	.1
08-1004			1	Assessories	
	24	03-1001	1	Elbow, 90°	2
	25	03-02922S	1	Nipple	.5
	26	04-10321	1	Valve, Ball	3
	27	03-1002	1	Bushing	.2
	28	-	-	-	-
	29	-	-	-	-
	30	-	-	-	-

ASSEMBLY No. 08-0002USP  
 MAJOR ASSEMBLY- VACUUM SYSTEM

	31	03-1021	3	Cap, Pipe	1
	32	-	-	-	-
	33A	07-1034W	1	Cover, Vacuum Generator	11
	33B	-	-	-	-
	34	02-10010	6	Bolt	.1
	35	06-25123	6	Washer, Flat	.1
	36	02-1100	6	Washer, Flat	.1
	37	02-1200	6	Nut, Nylon Insert	.1
	38	04-1057	1	Coupler, Air Twist	.1
	39	02-10004	1	Bolt	.1
	40	02-1200	1	Nut	.1
	41	-	-	-	-
	42	-	-	-	-
	43	-	-	-	-
	44	-	-	-	-
	45	-	-	-	-
	46	-	-	-	-
08-1009			1	Vacuum Tank Fabricated Assembly	
	47	07-1032	1	Tank Assembly	65
	48	04-1062	1	Fastener, Hood	1.1
07-10341	49		1	Valve, Vacuum Check Assembly	2.5
16037VPS	50		1	Screen, Welded Assembly	13
16037VPB	51		1	Bolt, Shoulder	.1
16037VPN	52		1	Nut, Washered Wing	.1
06-10162	53		50ft	Hose, Jet Fuel Bonded and Certified	25
03-0058S	54		1	Full Coupling	.2
03-11135	55		1	Reducer Bushing	.2
16037VPG	56		1	Vacuum Gauge	.2

CONFIDENTIAL-PROPRIETARY INFORMATION  
REPRODUCTION OF THESE DRAWINGS OR THE  
MANUFACTURING OF PRODUCTS FROM THESE  
DRAWINGS FOR USE BY ANYONE OTHER THAN  
SPOKANE INDUSTRIES INC. OF SPOKANE, WA  
IS STRICTLY PROHIBITED WITHOUT WRITTEN  
CONSENT

### SECTION 5.7

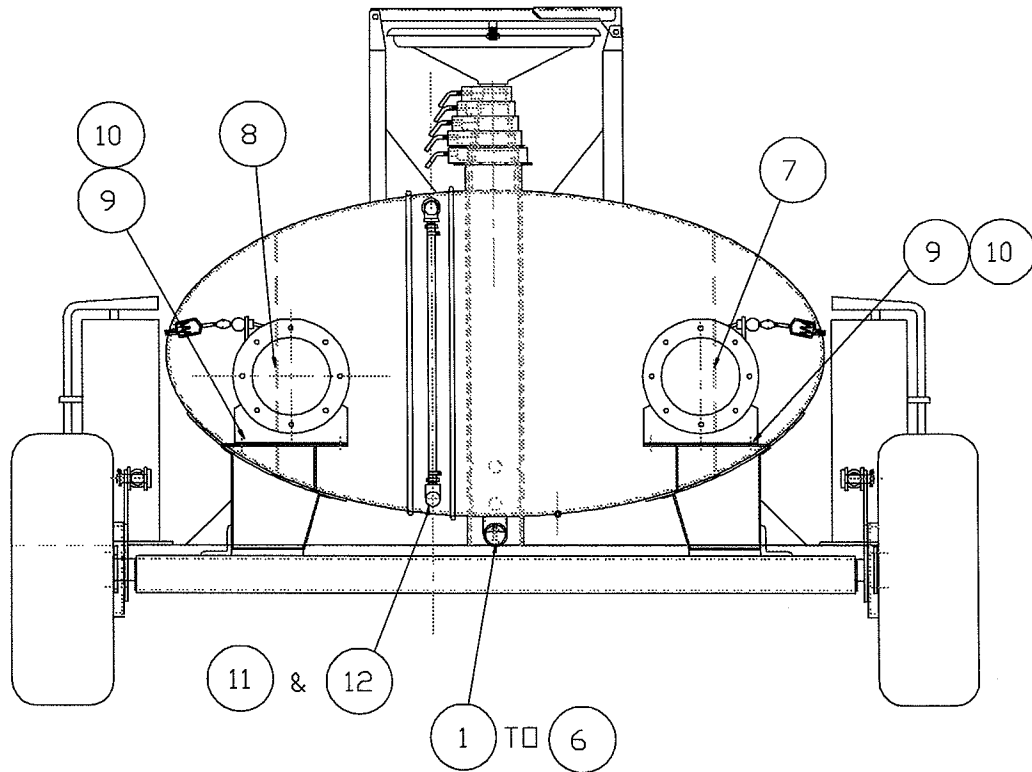
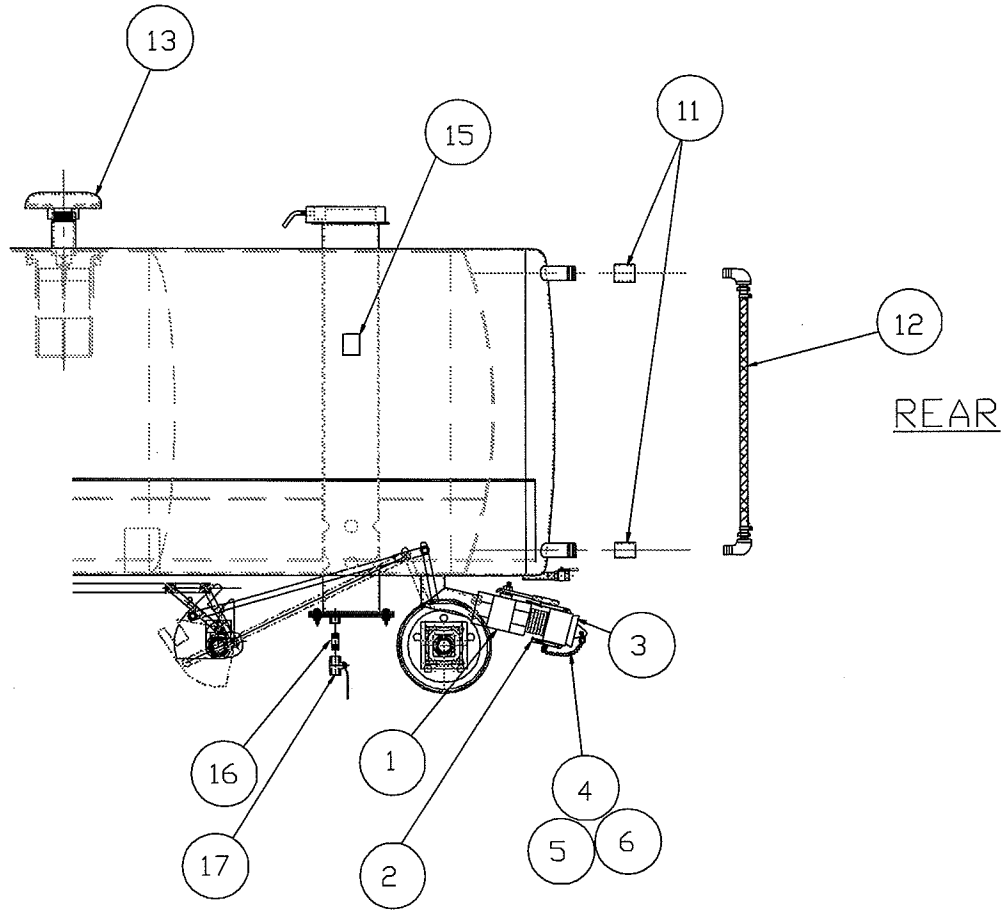

ASSEMBLY No. 10-100110SP  
 MAJOR ASSEMBLY- MISC. FIXTURES

Sub Assy.	Item	Part No.	Quantity	Description	Wt. #'s
08-1012			1	Drain Assemblby	
	1	04-10321	1	Valve, Ball Locking	6
	2	04-1033	1	Coupler, Camlock	1.5
	3	04-10331	1	Plug, Camlock	.5
	4	04-1034	1	Chain	.2
	5	04-1035	1	Link	.1
	6	04-10351	1	Hook, S-Type	.1
08-1013			1	Grounding Reel Assemblies	
	7	04-1036	1	Reel, Grounding Clamp Type	12
	8	04-1036	1	Reel, Grounding Clamp Type	12
	9	02-10040	4	Bolt	.3
	10	02-100115	4	Nut	.1
08-1014SP			1	Sight Gauge Assembly	
	11	03-0058S	2	Coupling, Full	.3
	12	08-1014SP	1	Sight Gauge Assy w/o Pit Cock Valve	5
04-1037	13		1	Vent Cover, Morrison	1
	14	-	-	-	-
16037PLG	15	9723K28	3	Bumper, Rubber, Tapered Square	
UANIP	16	03-0170S	1	Nipple, Short	.2
UAVAL	17	04-2506	3	Valve, Ball	.6

CONFIDENTIAL-PROPRIETARY INFORMATION  
 REPRODUCTION OF THESE DRAWINGS OR THE  
 MANUFACTURING OF PRODUCTS FROM THESE  
 DRAWINGS FOR USE BY ANYONE OTHER THAN  
 SPOKANE INDUSTRIES INC. OF SPOKANE, WA  
 IS STRICTLY PROHIBITED WITHOUT WRITTEN  
 CONSENT

## SECTION 5.8

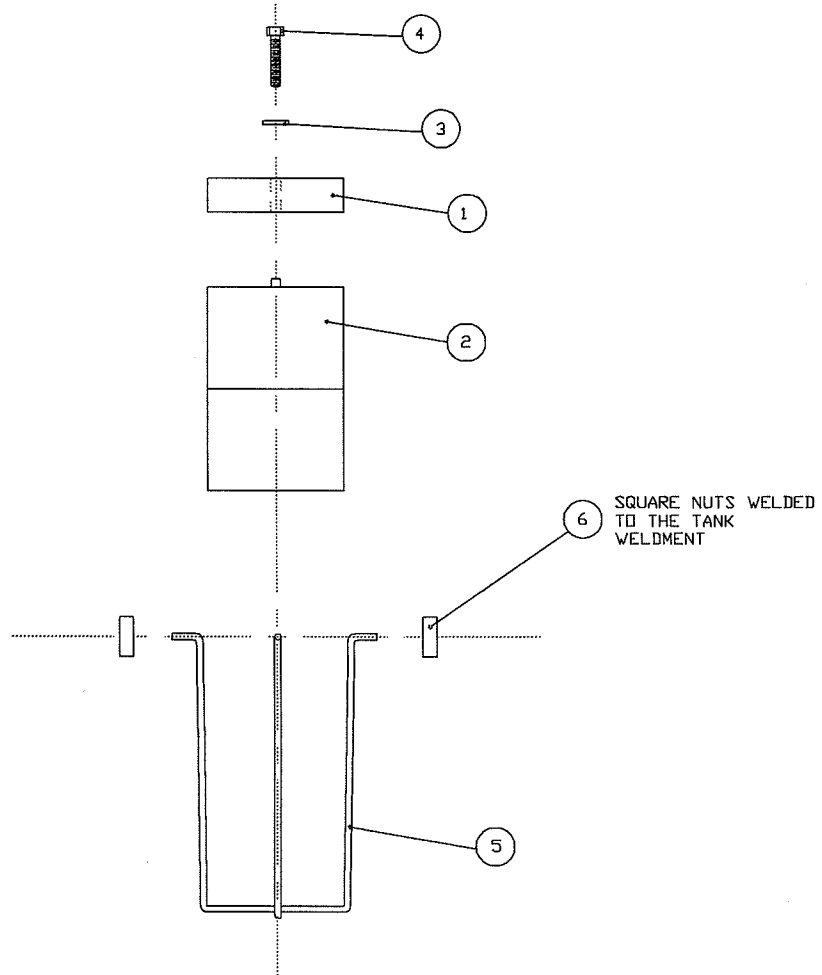

ASSEMBLY No. 08-10011  
 MAJOR ASSEMBLY- VENT, OVERFLOW PREVENTOR

Sub Assy.	Item	Part No.	Quantity	Description	Wt. #'s
08-1022			1	Float Assembly	2.7#
	1	04-1047	1	Gasket	.1
	2	06-1013	1	Float	.5
	3	02-1100	1	Washer	.1
	4	02-10001	1	Bolt	.1
08-1023			1	Gage Assembly	
	5	07-1032	1	Cage, Wire	.9
	6	02-12140	4	Nut	.1

CONFIDENTIAL-PROPRIETARY INFORMATION  
 REPRODUCTION OF THESE DRAWINGS OR THE  
 MANUFACTURING OF PRODUCTS FROM THESE  
 DRAWINGS FOR USE BY ANYONE OTHER THAN  
 SPOKANE INDUSTRIES INC. OF SPOKANE, WA  
 IS STRICTLY PROHIBITED WITHOUT WRITTEN  
 CONSENT

SECTION 5.9

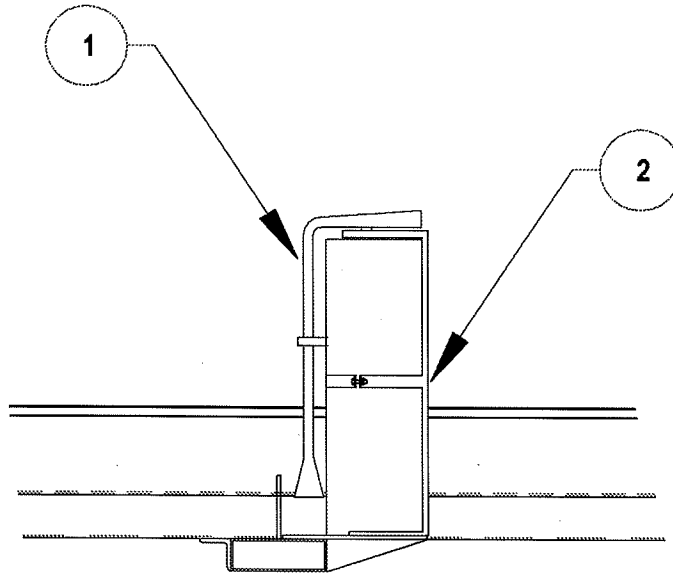

ASSEMBLY No. SMP16037FE  
 MAJOR ASSEMBLY- FIRE EXTINGUISHER

Sub Assy.	Item	Part No.	Quantity	Description	Wt. #'s
SMP16037FE			2	Fire Extinguisher Assembly	
	1	16037FE-1	1	Fire Extinguisher, 20# Purple K RC669161	25
	2	16037FE-2	1	Bracket, Fire Extinguisher Hold	1

SECTION 5.10

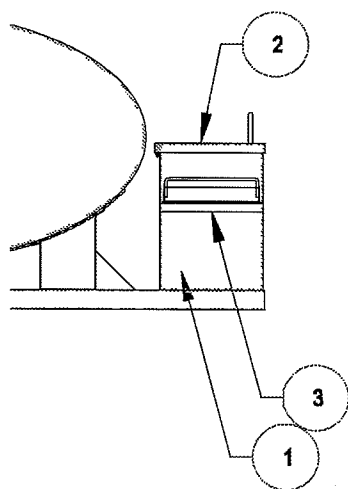
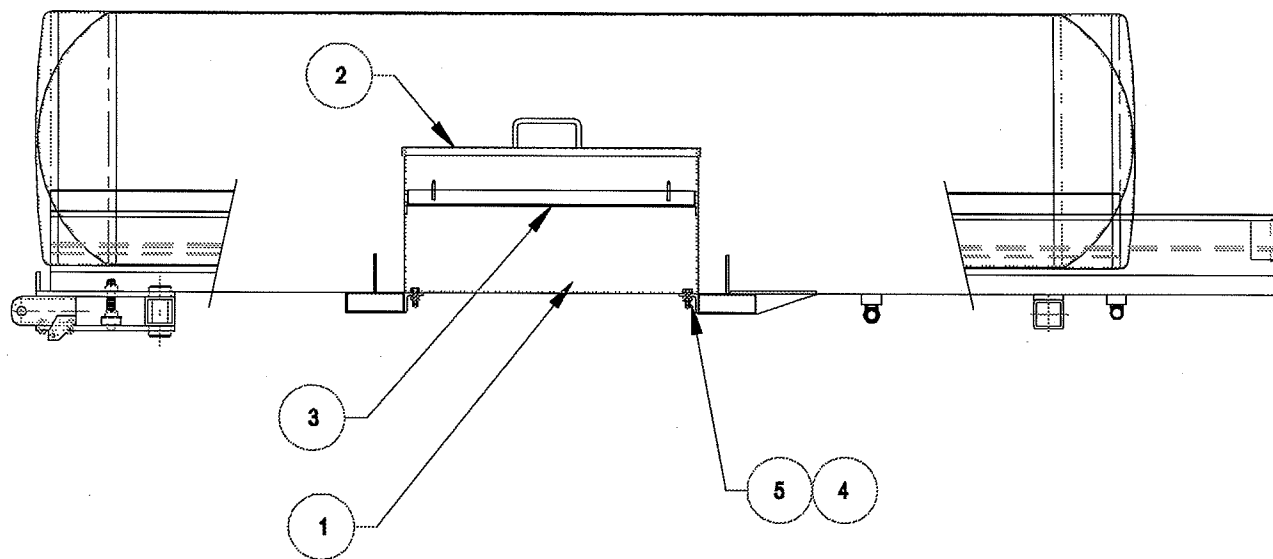

ASSEMBLY No. SMP16037TB  
 MAJOR ASSEMBLY- TOOL BOX

Sub Assy.	Item	Part No.	Quantity	Description	Wt. #'s
SMP16037TB			1	Tool Box Assembly	
	1	16037TB-1	1	Tool Box	18
	2	16037TB-2	1	Lid	6
	3	16037TB-3	1	Tray	8
	4	02-10013	1	Bolt	.6
	5	02-12014	1	Nut	.4

CONFIDENTIAL-PROPRIETARY INFORMATION  
 REPRODUCTION OF THESE DRAWINGS OR THE  
 MANUFACTURING OF PRODUCTS FROM THESE  
 DRAWINGS FOR USE BY ANYONE OTHER THAN  
 SPOKANE INDUSTRIES INC. OF SPOKANE, WA  
 IS STRICTLY PROHIBITED WITHOUT WRITTEN  
 CONSENT

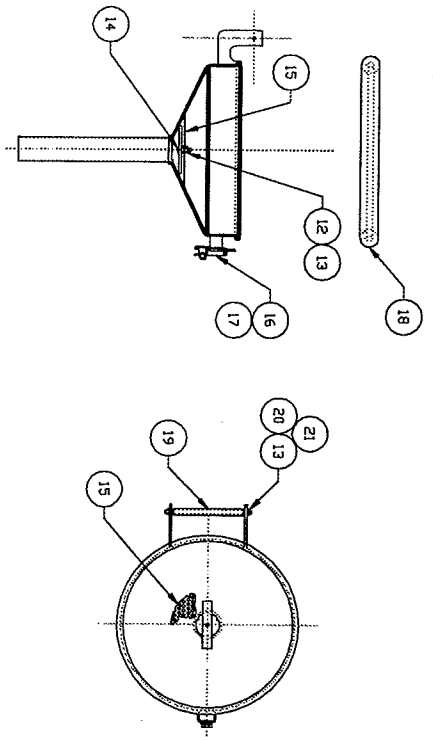

4 FUNNEL SECTION ASSEMBLY

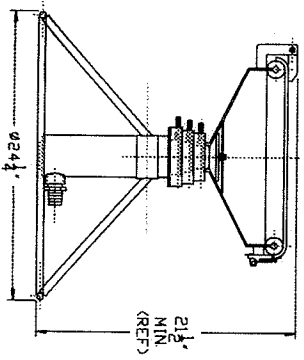

FUNNEL COLLAPSED DETAIL

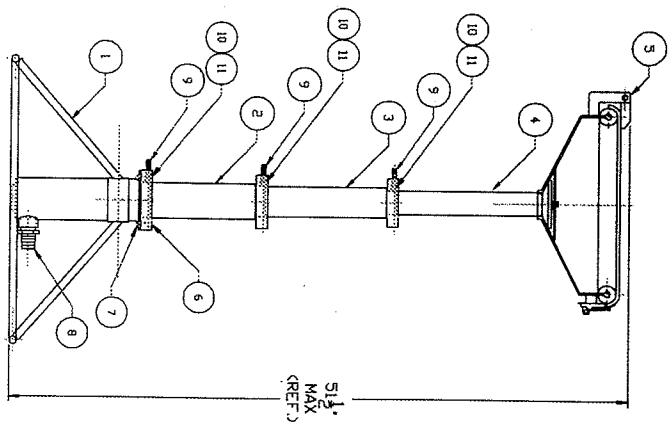

FUNNEL EXTENDED DETAIL

21	2	02-12003	WASHER	S/S	.02
20	1	01-91984S	1/4" ALL THREAD ROD	S/S	.1
19	1	01-9233S	PIPE	S/S	.2
18	1	06-1022	GASKET	RUB	.2
17	2	STOCK	RIVET	S/S	.01
16	1	04-1053	DRAW LATCH	S/S	.1
15	1	04-1039	PERERATED PLATE	S/S	.1
14	1	02-10002	CARRIAGE BOLT	S/S	.2
13	4	02-1200	NUT	S/S	.2
12	2	02-1100	FLAT WASHER	S/S	.1
11	3	04-0093	HELI-COIL	S/S	.1
10	3	05-0037	WEDGE	NYLON	.01
9	3	05-10182	HANDLE	S/S	.3
8	1	03-1003	HOSE BARB	ALUM	.24
7	3	02-10010	BOLT	S/S	.04
6	1	05-10012	BASE MOUNTING FLANGE	ALUM	1.22
5	1	07-11107	LID SECTION ASSEMBLY	ALUM	.36
4	1	07-11106	FUNNEL SECTION ASSY (INCLUDES ITEMS 12-21)	ALUM	4.70
3	1	07-11105	UPPER SECTION ASSEMBLY	ALUM	1.70
2	1	07-11104	LOWER SECTION ASSEMBLY	ALUM	1.83
1	1	07-11103	BASE SECTION ASSEMBLY	S/S	17.2
ITEM	QTY.	PART NO.	DESCRIPTION	MAT'L.	WGHT.

SUPPLEMENTAL DWG. NUMBERS		WORK ORDER W/O: XXXXX	TITLE: SERVICE MANUAL PRESENTATION USE, ONLY REMOTE DRAIN FUNNEL ASSEMBLY BOWSER
SALES ORDER S/O: XXXX		TOLS. EXCEPT AS NOTED FRACT. = 1/8" .XX = ± .13" .XXX = ± .005" ANG. = ± 1°	SIZE: A DWG. NO.: 07-1110U SCALE: - SH11 OF 1
APPROX. WGHT. 28.9#		 <b>SPOKANE INDUSTRIES</b> Spokane Metal Products Division P.O. Box 3303, Spokane, WA 99220 (509) 928 0720	

DRAWING/REVISION APPROVALS			
SYMB.	REQ. BY:	DESCRIPTION	DWN. BY/DATE
-	-	ORIGINAL ISSUE	MDD/ 8-24-92
-	-	REVISED PER MANUAL PRESENTATIONS	MDD/ 01-26-00
			ENG. MGR./DATE
			Q.C. MGR./DATE

# SPOKANE INDUSTRIES, INC.

SPOKANE METAL PRODUCTS DIVISION

Spokane Washington

## 400 GALLON FUEL BOWSER ONE YEAR LIMITED WARRANTY

Seller warrants its "400 Gallon Fuel Bowser" to be free from defects in material and workmanship under the normal use and service for which the unit is intended. If, but only if the unit has been properly operated, maintained and stored in accordance with printed directions contained in the product manual. Our obligation under this warranty shall be limited to the repair or exchange of equipment and parts which may prove defective within one year of the date the unit is put into service but shall in no event extend beyond a date two years from the date the unit is shipped from our plant. All transportation charges on parts returned to us for replacement under this warranty must be returned pre-paid.

This warranty does not extend to damages caused by environmental factors varying from normal design conditions, whether natural or man-made, or to units subjected to misuse, negligence or accident. This warranty likewise does not extend to the unit or any parts thereof which have been repaired or altered improperly or in any way so as to effect adversely its stability or reliability. This warranty does not cover parts or labor required to repair or replace parts whose usefulness is exhausted due to normal operation of this unit.

THIS WARRANTY IS EXPRESSLY IN LIEU OF ALL OTHER WARRANTIES, EXPRESS OR IMPLIED, INCLUDING ANY IMPLIED WARRANTY OF MERCHANTABILITY OR FITNESS FOR A PARTICULAR PURPOSE NOT SET FORTH IN A WRITING SIGNED BY AN AUTHORIZED REPRESENTATIVE OR SELLER. SELLER SHALL IN NO EVENT BE LIABLE FOR ANY CONSEQUENTIAL LOSS OR DAMAGE RESULTING FROM THE USE OR LOSS OF USE OF THIS UNIT.